



FAIRVIEW™

DEFINING ARCHITECTURE SINCE 1983



genesis™

PREFINISHED COMPRESSED FIBRE CEMENT / MANUFACTURED BY FAIRVIEW

INSTALLATION MANUAL

CONTENTS

Product Features	3
Product Range	4
Applications and Design	5
Health and Safety	6
Storage and Handling	7
Genesis Façade System Accessories	8
Installation Overview	12
Ventilation	13
Panel and Top Hat Layout	14
Top Hat Spacing	15
Top Hat Installation	17
Cutting	18
Edge Sealing	19
Panel Joints	20
Panel Installation	22
Panel Fixing	23
General Distances	24
Panel Fixing	25
Fixing Detail	26
Care and Maintenance	33

DISCLAIMER

The information contained in this publication and otherwise supplied to users of Genesis products is based on Fairview's general experience, best knowledge and belief. However, due to factors which fall beyond Fairview's knowledge and control, which can affect the use of the products, no warranty is given, express or implied with respect to fitness for particular purpose or otherwise.

It is the responsibility of the architect, designer and various engineering parties to ensure that the details in this Installation Manual are appropriate for the intended application.

Fairview reserves the right to alter specifications at any time and without notice. Products are subject to natural variation as part of the manufacturing process, colours and textures may vary according to light and weather conditions. Due to this and limitations of the printing accuracy, colours in this brochure may vary. In case of doubt, please contact your local Fairview representative.

PRODUCT FEATURES

PRE-FINISHED COMPRESSED FIBRE CEMENT FAÇADE PANEL SYSTEM. FOR USE WITH GENESIS RAW; HEWN; GROOVE; INFUSE; CLASSIC & RUSTIK.

Genesis CFC (Compressed Fibre Cement) façade system by Fairview is a modern building material that provides a versatile and durable façade suitable for an extensive range of buildings utilizing a self-ventilated façade.

Genesis CFC façade boards provide architects with freedom to apply and exploit the visual opportunities on any building façade. With multiple options for colour, shading and texture, we have created countless possibilities when designing your stunning façade.

Genesis CFC is manufactured from natural and environmentally friendly raw materials and is deemed a non-combustible material in accordance with C2D10(6)(d) of the National Construction Code. The panels are pre-finished, offer high impact strength and excellent sound and weather insulation.



KEY FEATURES



LOW MAINTENANCE

Genesis Raw, Hewn and Groove is virtually a maintenance free material that is scratch resistant with no re-sealing, painting or ongoing maintenance ever required during install or anytime thereafter.



ROBUST DURABILITY

Genesis panels are an exceptionally durable panel making it impact resistant. Even in the most demanding applications and harsh environments Genesis has a life expectancy exceeding 50 years.



EASILY CUT AND INSTALLED ONSITE

Genesis is easily cut to size and installed onsite minimising lengthy lead time between site measure, production and delivery of pre-finished panels.



COST EFFECTIVE

Genesis allows installers to provide a rapid and cost effective installation.



ENVIRONMENTALLY FRIENDLY



Genesis panels are installed on a ventilated sub-construction system allowing for the building envelope to breathe which increases thermal and energy efficiency and promotes healthier buildings.



THROUGH COLOURED MATERIAL

Genesis Raw, Hewn, Groove and Infuse are all through-coloured fibre cement material that offers elegant shades of natural colour.

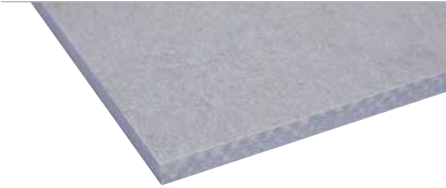
PRODUCT RANGE

	RAW	PROPERTIES Length 2500 / 3050mm Width 1250mm Thickness 8mm Weight 12.4kg/m ² Surface Natural textured	GENESIS RAW Length 2500 / 3050mm Width 1250mm Thickness 8mm Weight 12.4kg/m ² Surface Natural textured
	HEWN	PROPERTIES Length 2500 / 3050mm Width 1250mm Thickness Top 8mm Weight 12.4kg/m ² Surface Velvety, Sandblasted	GENESIS HEWN Length 2500 / 3050mm Width 1250mm Thickness Top 8mm Weight 12.4kg/m ² Surface Velvety, Sandblasted
	GROOVE	PROPERTIES Length 2500 / 3050mm Width 1250mm Thickness Top 9.5mm Thickness Groove 8mm Weight 14.1kg/m ² Surface Linear grooves	GENESIS GROOVE Length 2500 / 3050mm Width 1250mm Thickness Top 9.5mm Thickness Groove 8mm Weight 14.1kg/m ² Surface Linear grooves
	INFUSE	PROPERTIES Length 2500 / 3050mm Width 1250mm Thickness 8mm Weight 14.2kg/m ² Surface Smooth Matte Finish	GENESIS INFUSE Length 2500 / 3050mm Width 1250mm Thickness 8mm Weight 14.2kg/m ² Surface Smooth Matte Finish
	CLASSIC	PROPERTIES Length 2500 / 3050mm Width 1250mm Thickness 8mm Weight 14.2kg/m ² Surface Smooth Coated	GENESIS CLASSIC Length 2500 / 3050mm Width 1250mm Thickness 8mm Weight 14.2kg/m ² Surface Smooth Coated
	RUSTIK	PROPERTIES Length 2500 / 3050mm Width 1200mm Thickness 8mm Weight 15.1kg/m ² Surface Untreated/Natural	GENESIS RUSTIK Length 2500 / 3050mm Width 1200mm Thickness 8mm Weight 15.1kg/m ² Surface Untreated/Natural

APPLICATIONS

Genesis façade panels have been designed for use as external cladding on buildings. They are an ideal solution for Schools, Hospitals, Commercial Buildings and Residential Apartments that require a pre-finished and maintenance free façade.

Genesis CFC façade boards provide architects with freedom to apply and exploit the visual opportunities on any building façade. With multiple options for colour, shading and texture, we have created countless possibilities when designing your stunning façade.

DESIGN

1. COMPLIANCE

All design and construction must comply with the appropriate requirements of the current National Construction Code (NCC), regulations and standards.

2. SLAB AND FOOTINGS

The slab and footings on which the building is situated must be designed and certified by a qualified structural engineer according to all relevant codes, regulations and standards.

3. GROUND CLEARANCE

Make sure to follow the guidelines regarding distances as described in this manual. The facade board should finish between 10-30mm below the bottom end of the substructure. For overhang and similar, the maximum distance is 100mm.

The distance to terrain from the bottom edge of the facade board should be a minimum of 150mm. The distance to flat roofs, balconies and other horizontal structures, where the water can drain away, should be a minimum of 50mm.

4. MOISTURE MANAGEMENT

Genesis façade boards acts as a rain screen. To achieve a particular level of weather-tightness and ensure occupant comfort and protection of the building frame, the designer must determine the appropriate moisture management detailing for the project.

It is the responsibility of the builders and designers to identify moisture related risks associated with any particular building design. It is the responsibility of the builder to ensure appropriate moisture management

is provided during framed wall construction through effective use of flashings, sealants and vapour permeable membranes such as Genesis Wall Wrap weather barrier, building wraps, vapour retarders and damp proof course. Before installing panels, all wall openings, penetrations, intersections, connections, window sills, heads and jambs must incorporate appropriate flashing and waterproofing. Materials, components and the installation practices that are used to manage moisture in framed wall construction must, at a minimum, comply with the requirements of relevant standards, building codes and the manufacturer's specifications.

5. MOVEMENT CONTROL JOINTS

When installing Genesis façade boards, the movement of the façade boards and the support structure must be considered in the overall design of the system.

Movement joints in the panel layout should be aligned with movement control joints provided in the structural framing.

HORIZONTAL CONTROL JOINTS

A horizontal control joint is required beneath every floor junction to accommodate any expected deflection. The magnitude of the deflection must be verified by the project engineer.

VERTICAL CONTROL JOINTS

Vertical control joints to allow for differential movement are required every 12m along the façade, at supports of fascia trusses and at the junction of structural elements of different stiffness, such as between concrete walls and stud frames.

A control joint must also be installed when a masonry wall adjoins framed construction, and at the junction of framed additions or existing buildings, to allow for differential movement.

Vertical joints in panels must be aligned and extend for the full height of continuous panelling, although additional joints may be placed over openings for ease of installation.

6. DIRECTIONAL GRAIN

The Genesis Raw, Hewn and Groove panels are manufactured with a unique surface texture. This unique finish is enhanced by a process which adds a directional grain to the board - leaving the boards with a different appearance dependent on lighting and the angle of the board. By rotating boards within the façade makes it possible to obtain a playful visual effect – depending on the viewer's position and the lighting conditions

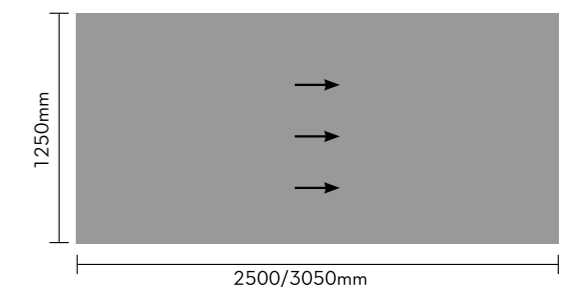

HEALTH & SAFETY

WARNING - DO NOT BREATHE DUST AND CUT ONLY IN WELL VENTILATED AREA

Genesis products contain sand, a source of respirable crystalline silica which may cause cancer. Breathing excessive amounts of respirable silica dust can also cause a disabling and potentially fatal lung disease called silicosis, and has been linked with other diseases.

During installation or handling:

1. work in outdoor areas with ample ventilation;
2. minimise dust when cutting by using a dust-reducing circular saw attached to an appropriate, well maintained, filtered vacuum;
3. warn others in the immediate area to avoid breathing dust;
4. wear a properly-fitted, approved dust mask or respirator (e.g. P1 or P2) in accordance with applicable government regulations and manufacturer instructions to further limit respirable silica exposures.

During clean-up use a vacuum and filter, both of which are well maintained and appropriate for capturing fine (respirable) dust. Alternatively, use wet clean-up methods - never dry sweep. For further information, refer to our Safety Data Sheets.

FAILURE TO ADHERE TO OUR WARNINGS, SAFETY DATA SHEETS, AND INSTALLATION INSTRUCTIONS MAY LEAD TO SERIOUS PERSONAL INJURY OR DEATH.

RECOMMENDED SAFE WORKING PRACTICES

CUTTING OUTDOORS

1. Position cutting station so wind will blow dust away from the user or others in working area.
2. Position the cutting station in a well-ventilated area. Use a dust-reducing circular saw attached to an appropriate, well maintained, filtered vacuum appropriate for capturing fine (respirable) dust.

DRILLING/OTHER MACHINING

When drilling or machining you should always wear a P1 or P2 dust mask and warn others in the immediate area.

IMPORTANT NOTES

1. For maximum protection (lowest respirable dust production) Fairview recommends always using best practice cutting methods where feasible.
2. **NEVER** use a power saw indoors.
3. **ALWAYS** use a saw blade that is purpose-made for cutting fibre cement products.
4. **NEVER** dry sweep - Use wet suppression or appropriate vacuum and filter.
5. **NEVER** use grinders.
6. **ALWAYS** follow tool manufacturers' safety recommendations.

DUST MASKS AND RESPIRATORS

Fairview recommends the use of P2 respirators as best practice. As a minimum, an AS/NZS1716 P1 respirator must be used when doing any activity that may create dust. For more extensive guidance and options for selecting respirators for workplaces please refer to Australian/New Zealand Standard 1715:2009 "Selection, Use and Maintenance of Respiratory Protective Equipment". P1 or P2 respirators should be used in conjunction with the above cutting practices to minimise dust exposure.

For further information, refer to Safety Data Sheet (SDS). If concern still exists about exposure levels or you do not comply with the above practices, you should always consult a qualified industrial hygienist or contact Fairview for further information.

STORAGE & HANDLING

STORAGE

1. Genesis façade boards are delivered on pallets with a plastic protection cover. If undamaged, the plastic cover provides protection against dust and weather conditions during transportation. Always store Genesis products on a flat, dry and level surface and support at 300mm maximum centres.
2. Do not stack the pallets more than two high, and ensure protective material is placed between the pallets.
3. If the pallets are stored outside, the plastic cover should be removed and replaced with a heavy-duty waterproof tarpaulin. Ensure ventilation around the tarpaulin to ensure condensation is reduced.
4. If the Genesis façade boards are stored on site for more than 2 weeks, they should be kept indoors in a dry and well-ventilated location.

LIFTING GENESIS FAÇADE BOARDS

When lifting Genesis façade boards, consider your lifting procedures in terms of both safety and avoiding damage to the boards.

1. Always lift panels cleanly off each other, do not slide panels over one another as scratching and damage may occur.
2. Panels should be carried horizontally on edge by at least two people.
3. When lifting large boards, use mechanical lifting gear if possible. If this lifting gear uses suction/vacuum, be careful not to apply too much suction, as this may damage the surface or leave permanent marks.

TRANSPORT

1. Moving panels that are stacked or palletized should be done with a forklift or crane
2. If using a forklift, ensure tines are wide enough apart to adequately support the panels
3. If using a crane, use wide, soft lifting straps that will not damage the panels
4. Panels should be strapped and secured to pallets before transporting or handling with a forklift or crane

GENESIS FAÇADE SYSTEM ACCESSORIES

SUB-FRAMING ACCESSORIES

CODE	NAME	DESCRIPTION	UNIT QUANTITY												
	Genesis Façade Board	Through-coloured, prefinished compressed fibre cement board. <table border="1"> <thead> <tr> <th>Width (mm)</th> <th>Length (mm)</th> <th>Thickness (mm)</th> </tr> </thead> <tbody> <tr> <td></td> <td>Standard</td> <td></td> </tr> <tr> <td>1250</td> <td>2500</td> <td>8</td> </tr> <tr> <td>1250</td> <td>3050</td> <td>8</td> </tr> </tbody> </table>	Width (mm)	Length (mm)	Thickness (mm)		Standard		1250	2500	8	1250	3050	8	LM
Width (mm)	Length (mm)	Thickness (mm)													
	Standard														
1250	2500	8													
1250	3050	8													
	3.5mm Back Flashing 3m	Used as a weather seal for horizontal joints between Genesis boards. 3.5mm x 0.48 BMT	1												
	35mm Perforated Base Flashing 50mm Perforated Base Flashing	Used at the base of wall to exclude vermin and allow ventilation. Available as: 35mm Perforated Base Flashing - 70 x 35 x 35 - 3000mm 50mm Perforated Base Flashing - 70 x 50 x 35 - 3000mm All profiles have a 4.8mm diameter perforated hole size.	1												
T12035S	120mm Steel Top Hat 2.9m	Designed to span vertically across the building structure to support the facade panels at vertical joints. Grade: G2 Steel Coating: Z 275 Thickness: 1.15BMT	1												
T12035L	120mm Steel Top Hat 5.8m	Designed to span vertically across the building structure to support the facade panels at vertical joints. Grade: G2 Steel Coating: Z 275 Thickness: 1.15BMT	1												
T5015S	15mm Steel Top Hat 2.9m	Galvanised Top Hat used as cladding substrate. Grade: G2 Steel Coating: Z 275 Thickness: 1.15BMT	1												
T5015L	15mm Steel Top Hat 5.8m	Galvanised Top Hat used as cladding substrate. Grade: G2 Steel Coating: Z 275 Thickness: 1.15BMT	1												
T5035S	35mm Steel Top Hat 2.9m	Metal top hat installed vertically for intermediate sheet support. Grade: G2 Steel Coating: Z 275 Thickness: 1.15BMT	1												
T5035L	35mm Steel Top Hat 5.8m	Metal top hat installed vertically for intermediate sheet support. Grade: G2 Steel Coating: Z 275 Thickness: 1.15BMT	1												

SUB-FRAMING ACCESSORIES

CODE	NAME	DESCRIPTION	UNIT QUANTITY
T5035PS	35mm Steel Top Hat Ventilated 2.9m	Galvanised Top Hat used as cladding substrate. Grade: G2 Steel Coating: Z 275 Thickness: 1.15BMT	1
T5035PL	35mm Steel Top Hat Ventilated 5.8m	Galvanised Top Hat used as cladding substrate. Grade: G2 Steel Coating: Z 275 Thickness: 1.15BMT	1

OTHER INSTALLATION ACCESSORIES



NAME	DESCRIPTION	UNIT QUANTITY
Gasket Tape	EPDM closed cell foam gasket tape with single sided self-adhesive. For use on vertical top hats. 48 x 3mm x 25m Roll 25 x 3mm x 25m Roll	1
Drill Bit	For use when pre-drilling Genesis boards. 9 x 35/70mm	1
Centering Drill Bit	Used for pre-drilling top hats. 9G/4.9mm	1
Stainless Steel Rivet	Used to face fix Genesis boards. The entire range of rivets come with washers attached and are colour coded to match the board. The fixed-point sleeves are sold separately in a box of 100. 4.8 x 20mm SS Rivet w/washer Sleeve for SS Rivet	100pcs
Stand-off Nosepiece	Special nosepiece that must be used for Genesis Signature Façade Rivets.	1
250mL Edge Sealer Kit	For use with Genesis boards to seal edges after cutting.	1
Saw Blade	Saw blade designed for fast and clean cutting of Genesis façade boards using a plunge or circular saw. 160mm Dia x 4T x 20mm	1

MEMBRANES

	CODE	NAME	DESCRIPTION	UNIT QUANTITY
	VWS50	Vitrafix Wall Sarking 1500mm x 50m Roll	Vitrafix Wall Sarking is a Class 4 vapour permeable membrane and an effective water barrier. With a 12-year warranty, it can withstand direct UV exposure for up to 3 months.	1 Roll
	VWSU30	Vitrafix Wall Sarking Ultra 1500mm x 30m Roll	Vitrafix Wall Sarking Ultra is a Class 4, heavy duty vapour permeable membrane and an effective water barrier. With a 15-year warranty, it can withstand direct UV exposure for up to 6 months and has superior strength characteristics for high wind zones.	1 Roll
	MSE150	Pro Clima Solitex Extasana Wall Membrane - 150	Pro Clima Solitex Extasana Wall Membrane is a high performance, monolithic nonporous membrane. Can be exposed to the elements for 90 days. 55m ² per roll.	1
	VWST25	Vitrafix Sarking Tape 60mm x 25m Roll	Vitrafix Sarking Tape is used for sealing overlapping joints and areas where water ingress may occur.	1 Roll
	VWSTD100	Vitrafix Double Sided Sarking Tape 60mm x 100m	Vitrafix Double Sided Sarking Tape is used to temporarily fix sarking to framing prior to installation of the facade.	1 Roll
	MTE60	Pro Clima Weathertight Sealing Tape – Tescon Extora 60mm	Weathertight Sealing Tape used to seal Pro Clima membrane. Easy to cut, thin and flexible, can be applied to cold and wet surfaces, highly UV stabilised.	10
	MTEP60	Pro Clima Corner Tape – Tescon Extora Profil 60mm	Split release paper for corner of window/door installations. Thin and flexible, can be applied to cold and wet surfaces, highly UV stabilised.	5
	MTE150	Pro Clima Sill Tape – Tescon Extoseal 150mm	Pro Clima Sill Tape - Tescon Extoseal is a one-piece stretchable sill tape, no need for corner moulds, can be applied to damp surfaces, very high adhesion on cold surfaces, no heating necessary, highly UV stabilised.	2
	VWSEPDMS	Vitrafix EPDM Sleeve – Custom	EPDM Sleeve is used to weatherproof areas where a fixture, such as a pipe etc, penetrates the sarking material. Custom sizes are available, contact the Fairview team with specific size requirements.	Please contact the Fairview team for more details

*The use of these accessories needs to be checked for compliance on your project

INSULATION

	CODE	PRODUCT	R-VALUE (M2K/W) ROUNDED TO 0.05	THICKNESS (MM)	DENSITY (KG/M3)	PACK M2	PACKS/PALLET
	RSS3502512	ROCKWOOL™ Safe'n'Silent Pro350 1200 x 600 x 25mm 12/PAC	0.70	25	60	8.64	12
	RSS350506	ROCKWOOL™ Safe'n'Silent Pro350 1200 x 600 x 50mm 6/PAC	1.45	50	60	4.32	12
	RSS350754	ROCKWOOL™ Safe'n'Silent Pro350 1200 x 600 x 75mm 4/PAC	2.15	75	60	2.88	12
	RSS3501003	ROCKWOOL™ Safe'n'Silent Pro350 1200 x 600 x 100mm 3/PAC	2.85	100	60	2.16	12
	RRS9502512	ROCKWOOL™ Rainscreen SL950 1200 x 600 x 25mm 12/PAC	0.70	25	80	8.64	12
	RRS950388	ROCKWOOL™ Rainscreen SL950 1200 x 600 x 38mm 8/PAC	1.10	38	80	5.76	12
	RRS950506	ROCKWOOL™ Rainscreen SL950 1200 x 600 x 50mm 6/PAC	1.45	50	80	4.32	12
	RRS950754	ROCKWOOL™ Rainscreen SL950 1200 x 600 x 75mm 4/PAC	2.15	75	80	2.88	12
	RRS9501003	ROCKWOOL™ Rainscreen SL950 1200 x 600 x 100mm 3/PAC	2.85	100	80	2.16	12

OTHER SIZES/THICKNESSES ARE AVAILABLE ON REQUEST. PLEASE CONTACT THE FAIRVIEW TEAM FOR MORE INFORMATION

INSTALLATION OVERVIEW

INSTALLATION OVERVIEW

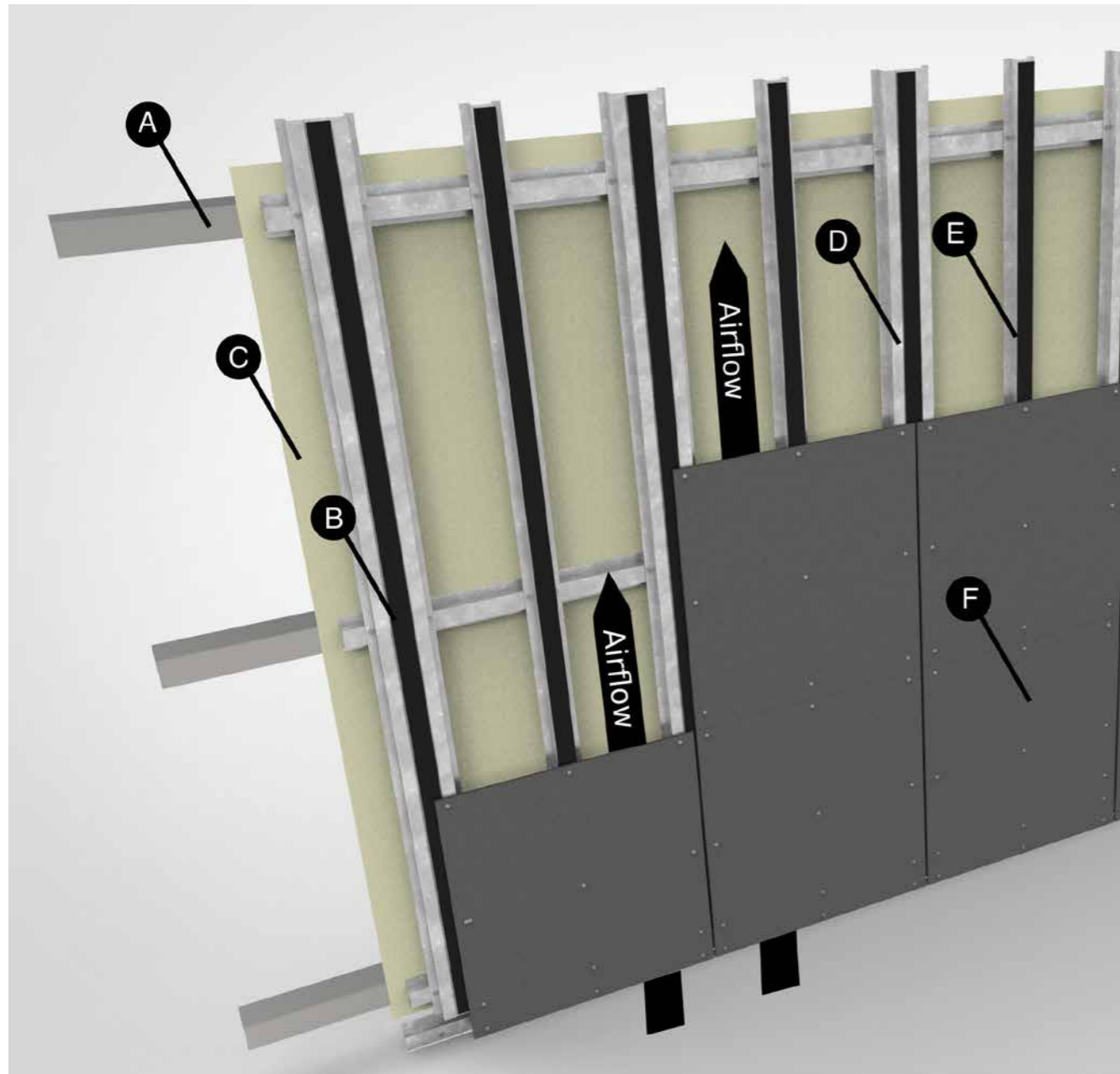

FIGURE 1.

- A. Structural Support
- B. Genesis Gasket Tape
- C. Vitrafix Sarking
- D. Genesis Joining Top Hat
- E. Genesis Intermediate Top Hat
- F. Genesis Façade Board

VENTILATION

Genesis façade boards are installed as a naturally ventilated façade, resulting in a temperature difference between the face of the cladding panel and the air cavity behind. This in turn creates a variation in air density causing air to flow upwards within the cavity resulting in a chimney effect.

Air enters at the base of the cladding creating an airflow that transports heat from the cavity out through openings at the top of the wall, reducing humidity and increasing the efficiency of insulation.

Benefits of ventilated façades:

THERMAL

Significant reductions in HVAC reliance through:

- A reduction in the amount of heat the building absorbs in hot weather conditions from the partial reflection of solar radiation by the outside façade, and the naturally ventilated air cavity.
- In cold weather conditions ventilated walls retain heat, resulting in a lower reliance on heating. HVAC electricity consumption typically accounts for around 40% of total building consumption.

ACOUSTIC

Ventilated façade systems provide an increase in the reflection of external noise, with some projects achieving an average reduction of up to 8dB. With the primary external noise sources affecting buildings being road traffic noise, a reduction of this level can greatly improve occupant comfort.

STRUCTURAL

Ventilated façades don't suffer from mould, fungi and rot, making them extremely durable and virtually maintenance free. The natural bottom-to-top airflow through the cavity assists in eliminating moisture accumulation on the façades, helping to prolong the structural integrity and ultimately the lifespan of a building.

Ventilation cavities are required at the top and bottom of the façade as well as under and over openings such as doors, windows and cut outs.

These openings need to be protected against the entry of birds and vermin into the cavity space.

Effective protection is normally achieved by fitting a perforated profile to the opening. Perforations must be sized correctly in order to allow air flow and prevent entry of vermin.

A minimum ventilation gap of 10mm is required, or equivalent to 100cm² per meter.

If perforated profiles are used, a minimum ventilation area of 100cm² per meter is required.

The opening at the base is also required to drain moisture from within the façade cavity.

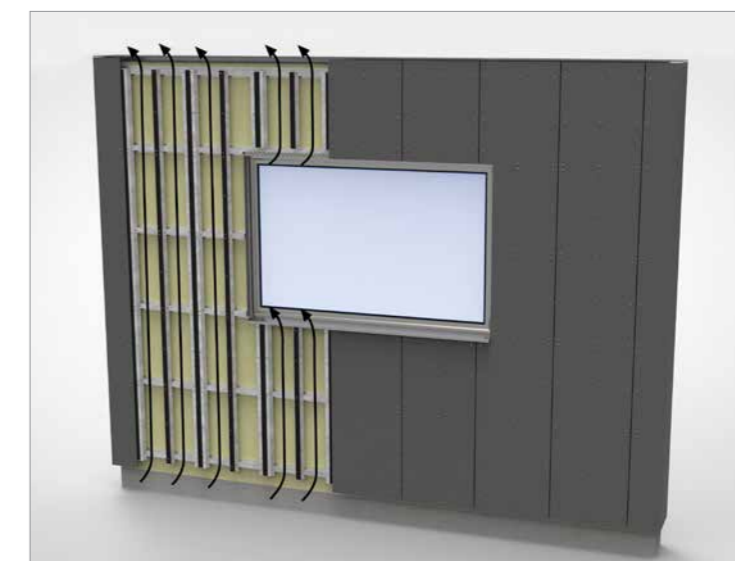

FIGURE 2. Ventilation air flow

PANEL AND TOP HAT LAYOUT

PANEL & TOP HAT LAYOUT

Genesis façade boards can be installed upright horizontally or vertically. The panel layout will determine the location of the Genesis Joining Top Hat and Genesis Intermediate Top Hat. The vertical expressed joints may be aligned or offset in a brick pattern layout.

KEY

- JTH: Genesis Joining Top Hat
- ITH: Genesis Intermediate Top Hat

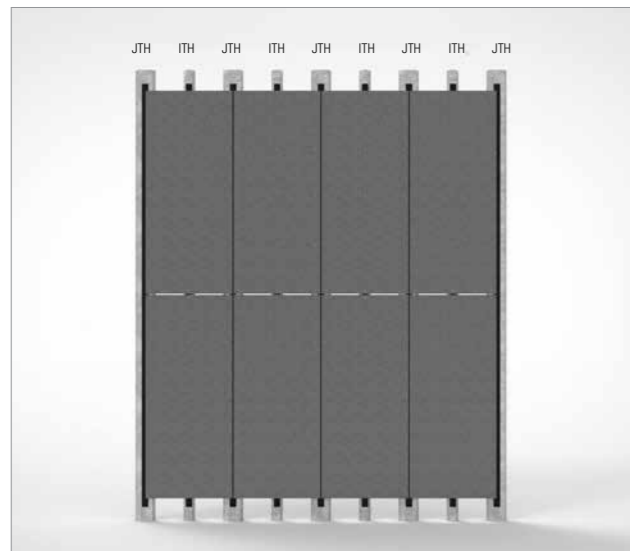

FIGURE 3. Vertical Layout Aligned Grid Pattern.

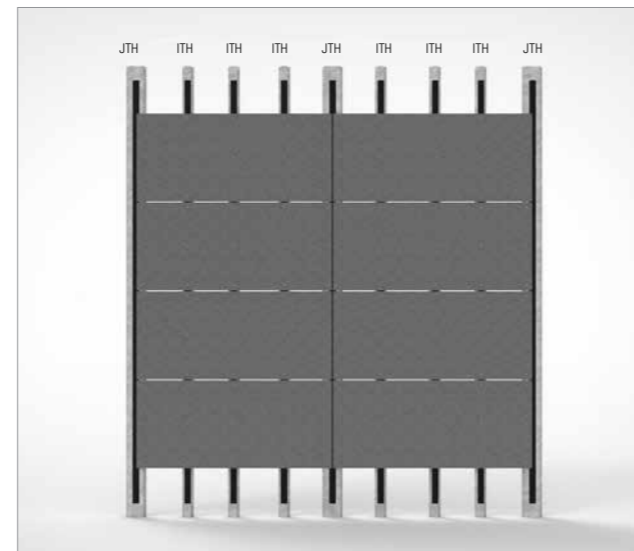

FIGURE 4. Horizontal Layout Aligned Grid Pattern.

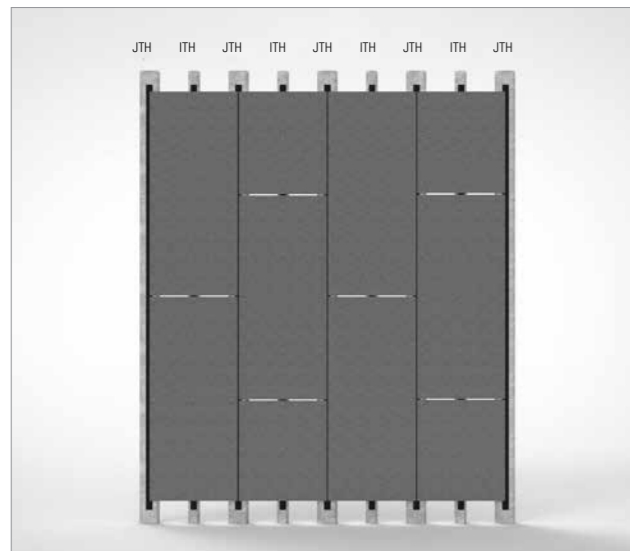

FIGURE 5. Vertical Layout Brick Grid Pattern.

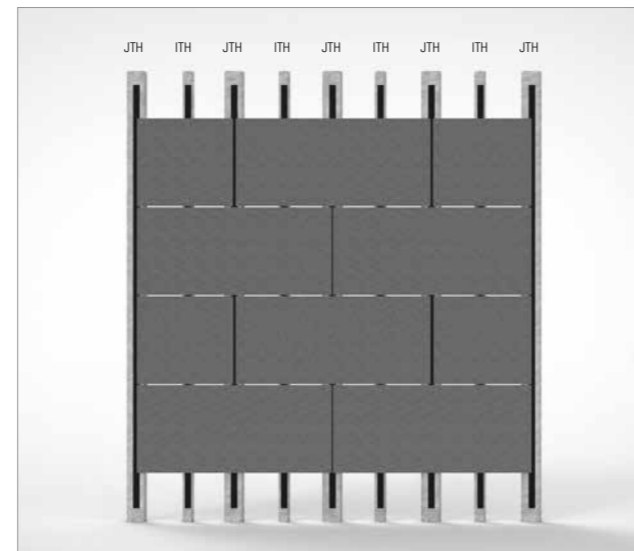

FIGURE 6. Horizontal Layout Brick Grid Pattern.

TOP HAT SPACING

GENESIS JOINING AND GENESIS INTERMEDIATE TOP HATS

DESIGN WIND PRESSURE (Ultimate) kPa	MAXIMUM SPAN OF VERTICAL GENESIS TOP HATS			
	Spacing of Vertical Top Hats (mm)			
	300	400	450	630
1.0	2450	2250	2150	1950
1.5	2150	1950	1900	1700
2.0	1950	1800	1700	1550
2.5	1800	1650	1600	1350
3.0	1700	1550	1450	1200
3.5	1600	1400	1350	1100
4.0	1550	1300	1200	NA
4.5	1450	1200	1150	NA
5.0	1350	1150	1050	NA
5.5	1300	1100	1000	NA
6.0	1200	1000	950	NA
6.5	1150	950	NA	NA
7.0	1100	950	NA	NA

TABLE 2.

- NOTE:**
- The design capacities of the Genesis façade system are in limit state format and intended for use with AS/NZS 1170.2. To obtain equivalent permissible load capacity, divide the "ultimate wind capacity" in Table 6.04 or Table 6.06 by 1.5.
 - Indicates values suitable only where Genesis boards are fixed to three or more top hats.
 - Cantilever maximum 0.2 x adjacent span
 - Genesis Intermediate and Genesis Joining Top Hats connection to horizontal Genesis Horizontal Top Hat or structural steel support of minimum 1.10mm BMT use 2 x 12g-14TPI x 20mm screws.

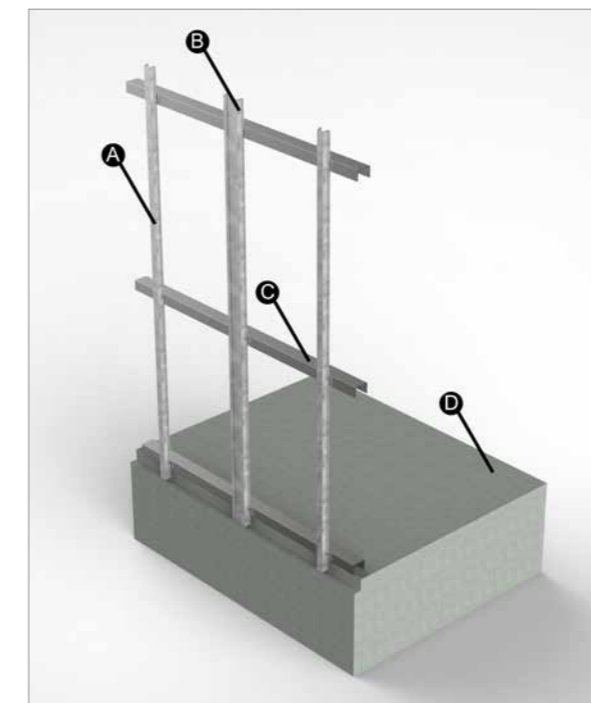

- A. Genesis Intermediate Top Hat
- B. Genesis Joining Top Hat
- C. Steel Framing
- D. Concrete Flooring

FIGURE 7.

TOP HAT SPACING

GENESIS HORIZONTAL TOP HAT

DESIGN WIND PRESSURE (Ultimate) kPa	SPACING OF GENESIS HORIZONTAL TOP HAT FIXED TO THREE OR MORE STUDS			
	Studs 0.75BMT Stud Spacing (mm)		Studs 1.10BMT Stud Spacing (mm)	
	450	600	450	600
1.0	1768	1473	1974	1769
1.5	1179	982	1316	1179
2.0	884	737	987	885
2.5	707	589	790	708
3.0	589	491	658	590
3.5	505	421	564	505
4.0	442	368	494	442
4.5	393	327	439	393
5.0	354	295	395	354
5.5	322	268	359	322

TABLE 1.

NOTE: Genesis Horizontal Top Hats connection to steel stud frame of minimum 0.75mm BMT use 2 x 14g hex head screws at each stud.

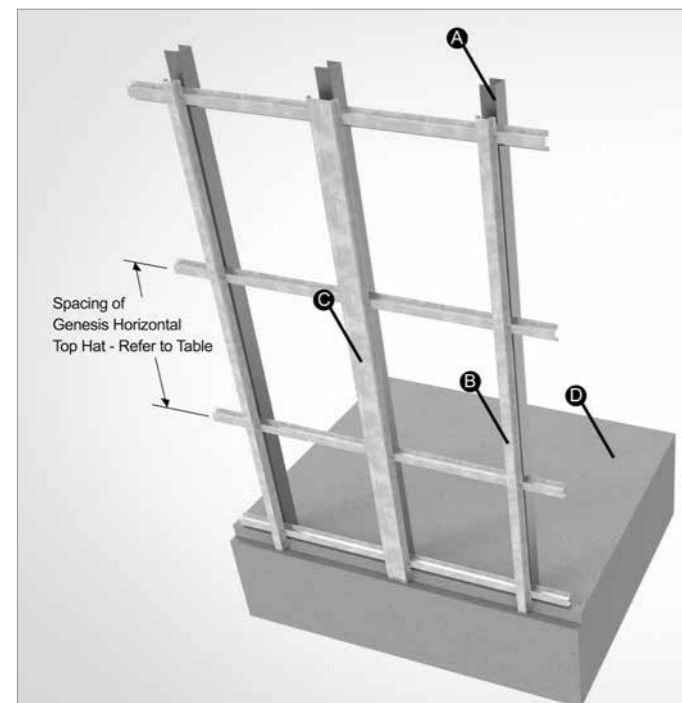

- A. Structural Steel
- B. Genesis Intermediate Top Hat
- C. Genesis Joining Top Hat
- D. Concrete Flooring
- E. Genesis Horizontal Top Hat

FIGURE 8.

TOP HAT INSTALLATION

Genesis façade boards can be installed on the Genesis top hat fixing system. Certification for the structural stability of any supporting frame should be in accordance with local building regulations and must be obtained by the building owner or official representatives, such as the project engineer.

The Genesis system includes the Genesis Joining Top Hat and the Genesis Intermediate Top Hat.

- Before installing on a load bearing wall, ensure the wall is plumb and straight and that the support system can be mounted safely.
- Horizontal tolerance (+/- 1.5mm over 1m)
- Vertical tolerance (+/- 0.5mm over 600mm)
- Top hats must be installed in accordance with Table 1 and Table 2.
- Top hats must be installed vertically and must be broken at floor levels.
- Top hats must be fixed to the structure as per the structural engineer specifications.
- Genesis façade boards must never cross a joint in the top hat subframe. Ensure the top hat joints align with the panel joints.
- Ensure a minimum 20mm gap between the top hats (see Figure 9)
- Install vertical gasket to central section of the Genesis Top Hats for the full extent of panels. Be careful not to stretch the gasket when installing. When joining gasket, cut ends cleanly and push together before adhering.

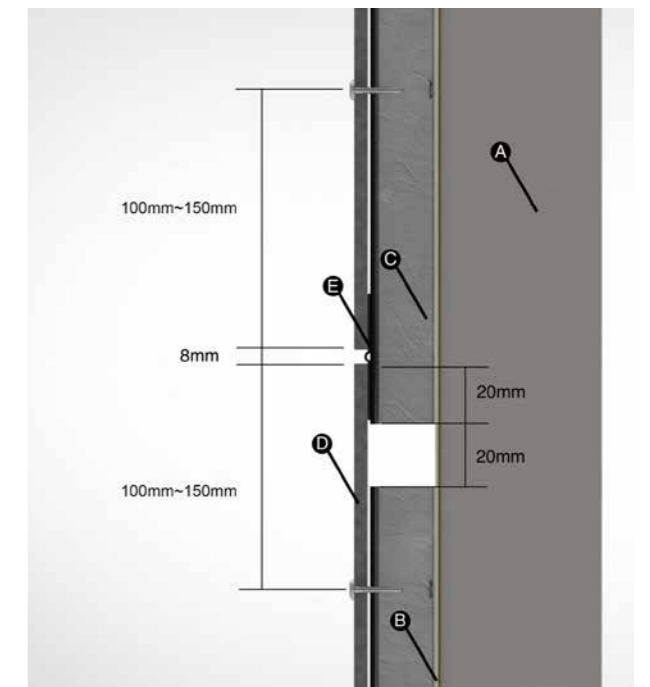

FIGURE 9.

- A. Steel Frame
- B. Vitrafix Sarking
- C. Genesis Intermediate Top Hat
- D. Genesis Façade Board
- E. Genesis 3.5mm Back Flashing

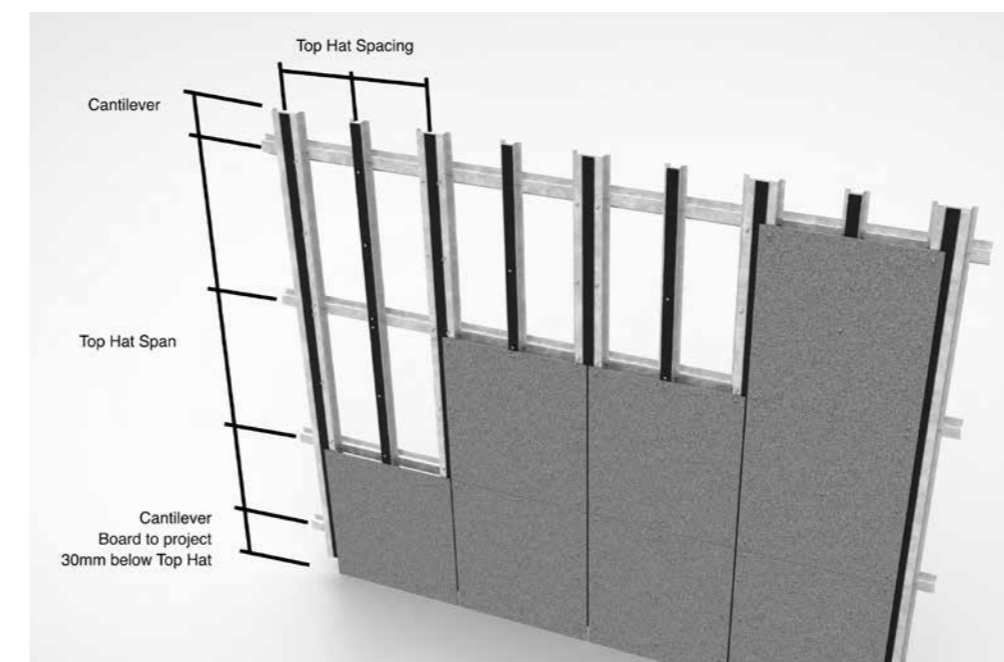
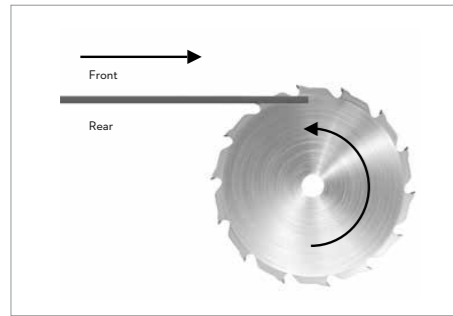

FIGURE 10.

CUTTING

When cutting Genesis façade boards, it is important to use the correct blade. Fairview recommends using a special purpose fibre cement saw blade used with a dust-reducing saw. A dust-reducing saw uses a dust deflector or a dust collector which can be connected to a vacuum extraction system.

To achieve the best quality cut and to know which side to cut from, ensure to follow these instructions. The direction varies depending on which saw you use.



WHEN USING A TABLE SAW, PLACE THE BOARD WITH THE FACE UP ON THE TABLE AND CUT FROM THE REAR OF THE BOARD.

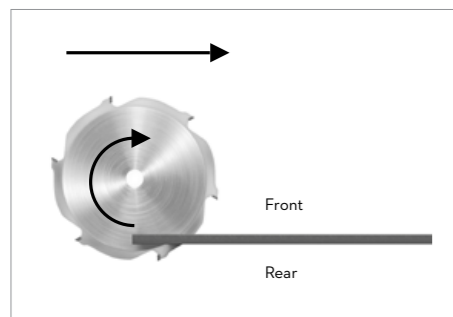

WHEN USING A MITRE SAW OR DROP SAW, CUT THE BOARD FROM THE FRONT.

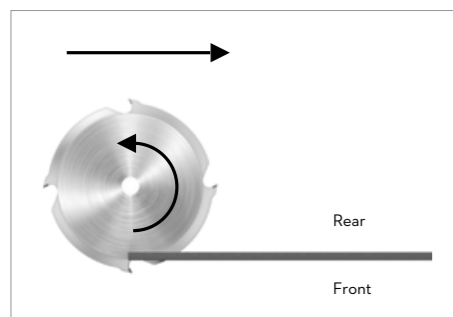

WHEN USING A CIRCULAR SAW OR DIVE SAW, CUT THE BOARD FROM THE REAR.

Once boards are cut, edges should be bevelled with sand paper to reduce the possibility of damage and improve the panel appearance. Use 80-grit sand paper on a block of flat timber or board to sand edges.

Dust from cutting or drilling must be removed immediately after the work has been completed, otherwise it can mark the surface of the boards.

All cut edges on Genesis Infuse, Depth and Classic boards must be sealed with Genesis Edge Sealer to ensure protection of the cut edges.

EDGE SEALING

Genesis Edge Sealer should be used to protect all edges of Genesis Classic, Infuse and Depth boards when cut on-site. Factory-cut edges are always factory pre-sealed.

BEFORE TREATING BOARDS

The boards must be dry, and edges clean and free from dust and dirt before applying the Edge Sealer. It is useful to roughen the edges with sandpaper (grade 80). Edges must be sealed immediately after cutting.

APPLICATION CONDITIONS

Board and air temperature should be between + 5°C to + 30°C and relative humidity should be below 85%.

APPLICATION

If application is not to be carried out in a well-ventilated room or outdoors, use respiratory equipment. Wear goggles and gloves while applying Edge Sealer as set out in the safety data sheet.

If there is protective film on the board, leave it in place until the Edge Sealer has dried.

Shake Edge Sealer before use. Apply it in a thin layer with the sponge applicator supplied in the Genesis Edge Sealer set.

Avoid getting excess Edge Sealer on board faces. If this does occur, remove immediately with a lint free cloth.

Ensure that the entire edge has been sealed with a thin layer before continuing to the next edge. Apply Edge Sealer to individual boards separately, not while stacked.

DISPOSAL

Disposal of Genesis Edge Sealer should be done in accordance with local and national regulations.

NOTE: Genesis Raw, Hewn and Groove should NOT be sealed with Genesis Edge Sealer.



PANEL JOINTS

Genesis façade boards are installed with an expressed joint between adjacent panels, vertically and horizontally. The joint is to be a minimum of 8mm and maximum of 16mm.

HORIZONTAL JOINTS

Genesis façade boards can be joined horizontally either closed with a Genesis 3.5mm Back Flashing (see Figure 11) or as an open joint (see Figure 12).

Note: if using an open horizontal joint, the supporting frame is visible. The joints may need to be concealed using tape or paint.

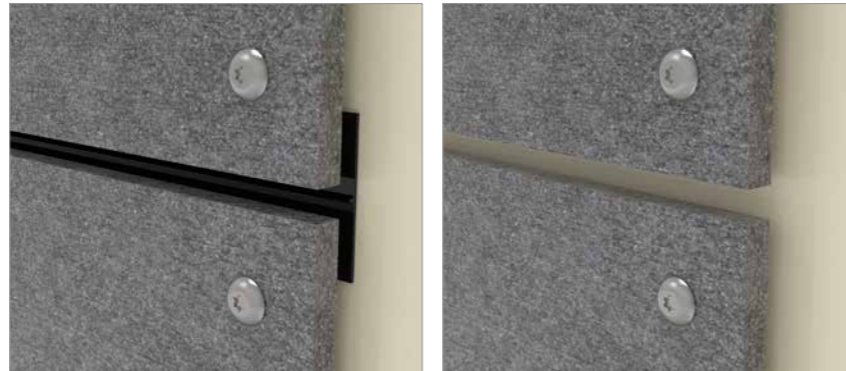

FIGURE 11.

FIGURE 12.

VERTICAL JOINTS

Genesis façade boards are always joined vertically on a continuous top hat. Genesis Façade Gasket Tape is applied to the central section of the Genesis Joining Top Hat for the full extent of the panels, creating a black-out of the vertical joint (see Figure 14).

Genesis Façade Gasket Tape is also applied to the Genesis Intermediate Top Hat to assist with movement and minimize any vibration in the panels (see Figure 13).

HORIZONTAL CROSS SECTION INTERMEDIATE TOP HAT

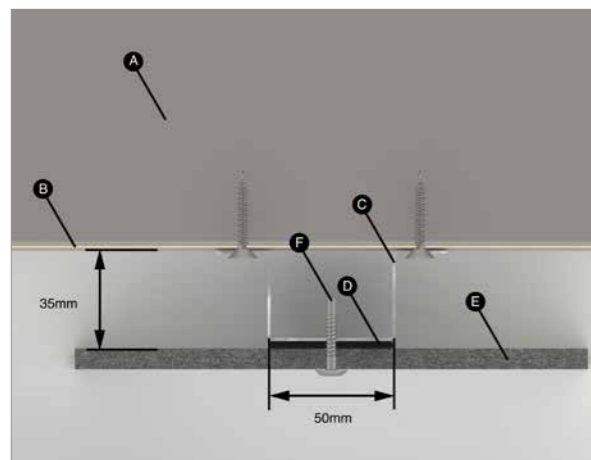

FIGURE 13.

- A. Steel Framing
- B. Vitrafix Sarking
- C. Genesis Intermediate Top Hat
- D. Genesis Gasket Tape
- E. Genesis Façade Board
- F. Genesis Façade Rivet

HORIZONTAL CROSS SECTION VERTICAL JOINT

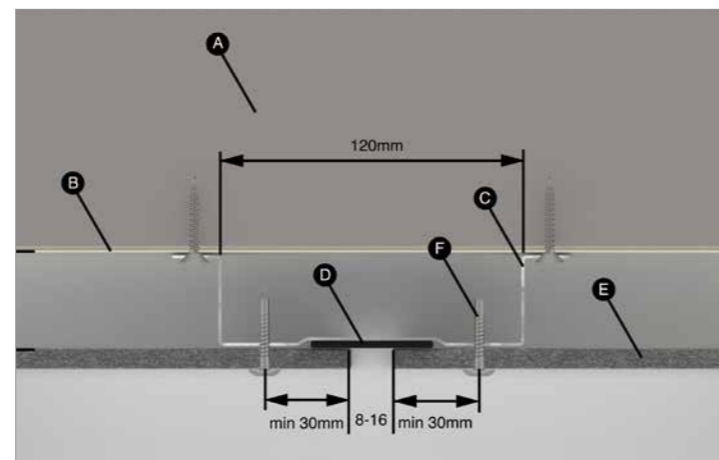

FIGURE 14.

- A. Steel Framing
- B. Vitrafix Sarking
- C. Genesis Joining Top Hat
- D. Genesis Gasket Tape
- E. Genesis Façade Board
- F. Genesis Façade Rivet

PANEL JOINTS

Genesis façade boards are ideal for use as ceilings and soffits. The solution can be used for both exterior and interior applications. The boards can be installed on profiles directly mounted to a concrete deck or wooden structure, or they can be used as part of a solution with a suspended ceiling system. It is possible to change or remove the Genesis façade boards to access any hidden installations as the boards are mounted using visible rivets.

Installing 8mm Genesis façade boards on a steel structure - as ceiling or soffit Max support distances: 400mm Max rivet centres: 400mm the edge distances when using Genesis façade boards as ceiling or soffit are in principle the same as for façade boards in which the direction of the sub-structure and the orientation of the board define the edge distances. This also applies to hole sizes, joints, and distances to other building materials.

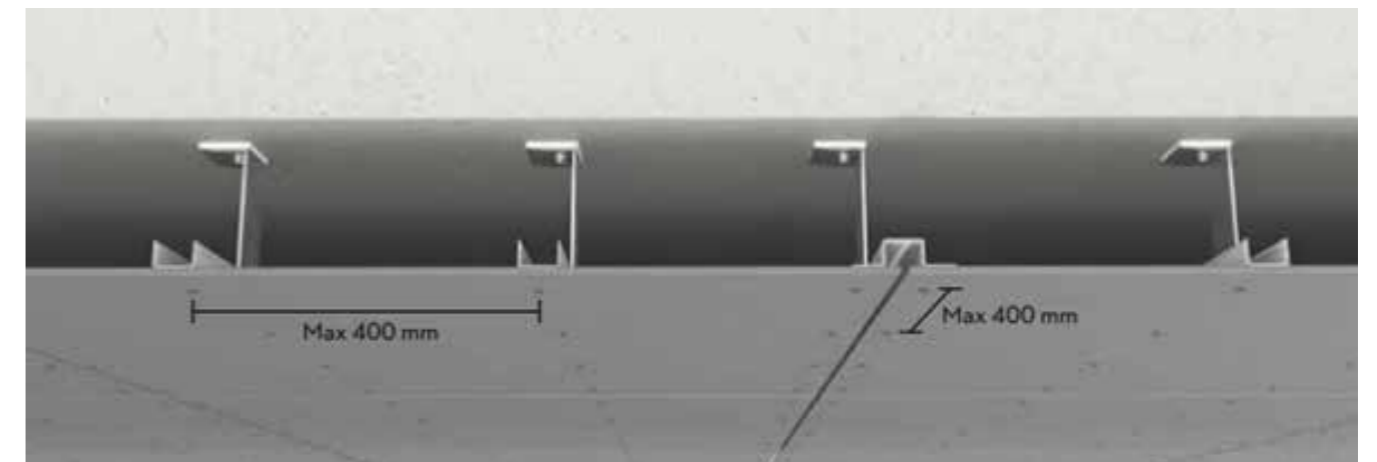

When using Genesis façade boards as ceiling or soffit, you can normally use a regular steel system with steel profiles, but for larger cavities, you need to contact a steel manufacturer to make sure the system fits your needs. The number of brackets and types of anchoring used for the type of deck/ ceiling must be calculated, and the manufacturer's instructions should always be followed.

PANEL INSTALLATION

Genesis façade boards are installed with an expressed joint between adjacent panels, vertically and horizontally. The joint is to be a minimum of 8mm and maximum of 16mm.

- When installed in a vertical layout, the boards must have only two fixed points as close to the centre of the panel as possible. (see Figure 15 & 16)
- If the panel is installed horizontally or runs across two intermediate top hats, the board must have two fixed points as close to the centre of the panel as possible and must be aligned horizontally. (see Figure 17)
- All other fixing positions must be sliding points.
- Genesis façade boards must be fixed in accordance with Table 3 and minimum edge distances as specified in Figure 11 and Figure 12. Appropriate panel fixing layout should be selected for the project Design Wind Pressure and Top Hat Spacing.
- All panels must be pre-drilled using a 9mm fibre cement drill bit.
- When installing Genesis, begin with the two fixed points (1 then 2), followed by the remaining gliding points above the fixing positions and finally the gliding points below. (see Figure 18)
- Genesis façade boards must never cross a joint in the top hat subframe, rather the panel joints should align with the top hat joints.

KEY
 X Fixed Point ● Sliding Point

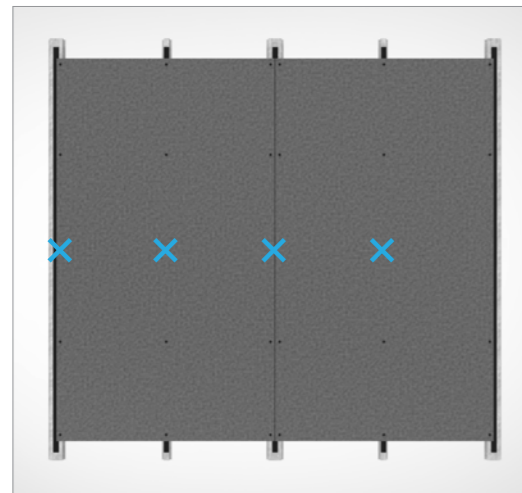

FIGURE 15.

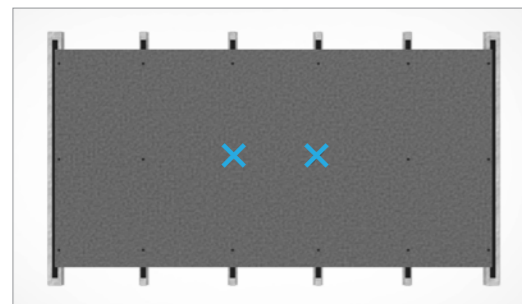

FIGURE 17.

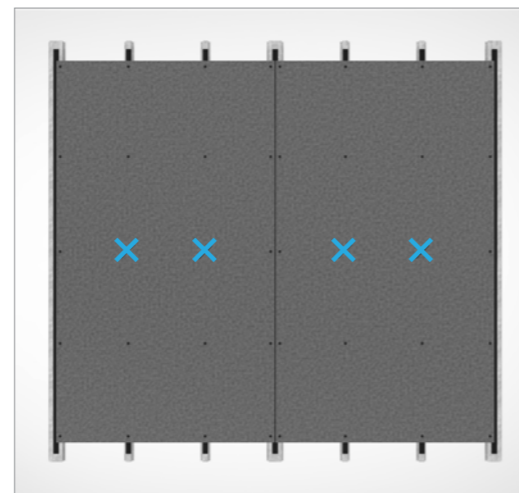

FIGURE 16.

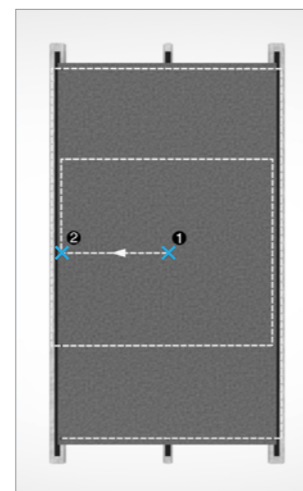

FIGURE 18.

PANEL FIXING

DESIGN WIND PRESSURE (Ultimate) kPa	PANEL FIXING REQUIREMENTS AND MAXIMUM TOP HAT SPACINGS	
	Spacing of Vertical Top Hats (mm)	Max Fixing Spacing (mm) along Top Hats
1.0	630	600
1.5	630	600
2.0	630	600
2.5	630	600
3.0	630	500
3.5	600	500
4.0	400	500
4.5	400	500
5.0	400	500
5.5	400	400
6.0	400	400
6.5	400	400
7.0	400	300

TABLE 3.

NOTE: - The Genesis façade boards fixed to Genesis Joining Top Hats and Genesis Intermediate Top Hats using Genesis stainless steel rivet fasteners (4.8x29mm).

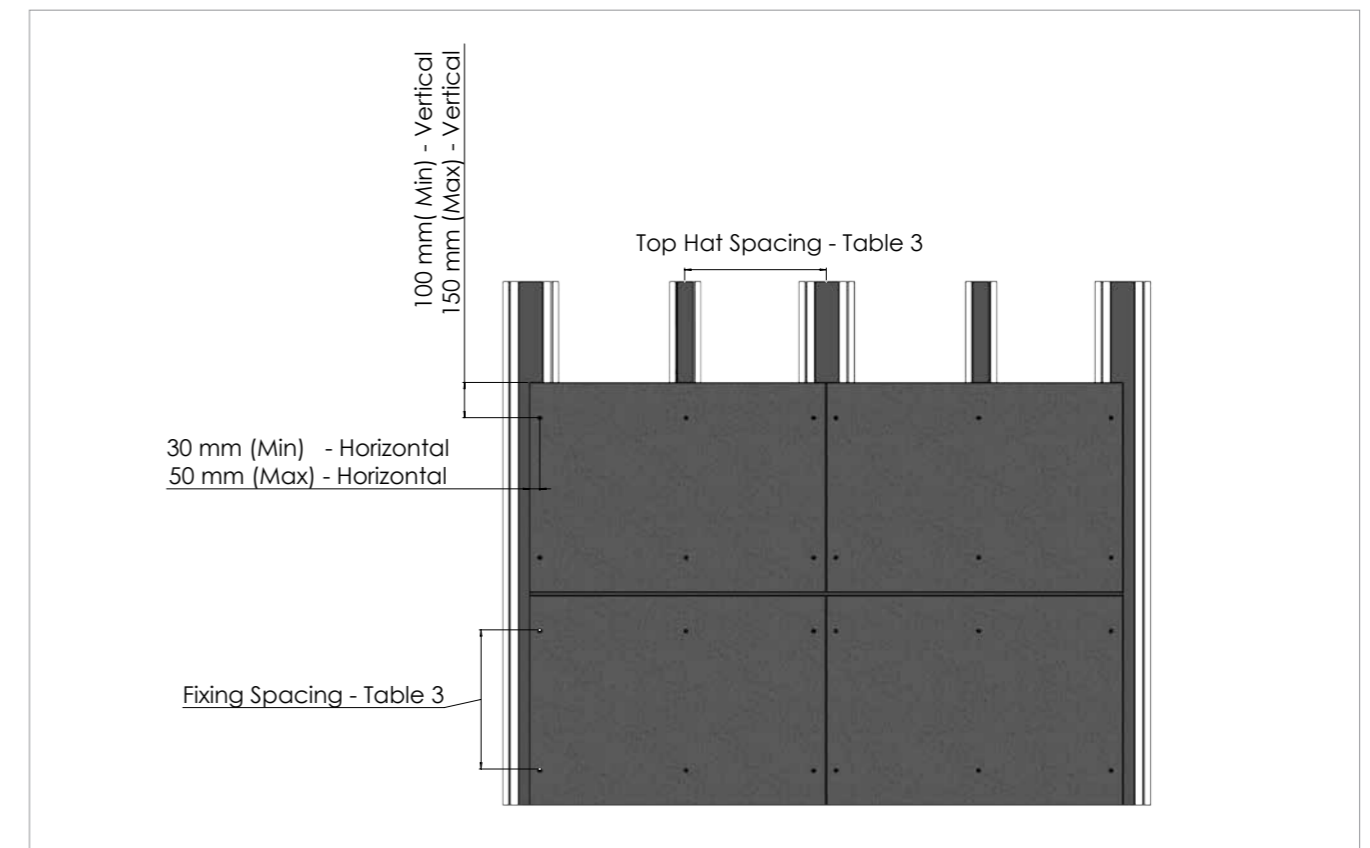

FIGURE 19.

GENERAL DISTANCES

Ensure to install according to the following guidelines regarding distances described in this manual.

- The façade board should finish between 10 and 30mm below the bottom end of the substructure.
- For overhang and similar, the maximum distance is 100mm.
- The distance to terrain from the bottom edge of the façade board should be a minimum of 150mm.
- The distance to flat roofs, balconies and other horizontal structures, where the water can drain away, should be a minimum of 50mm.
- Vertical clearance to profiles such as Genesis Back Flashing or corner profiles should be a minimum of 4mm.
- For horizontal clearances at windows and doors etc., you must leave a minimum of 10mm for ventilation.
- The clearance to other building materials should be minimum 8mm for movement and water drainage.

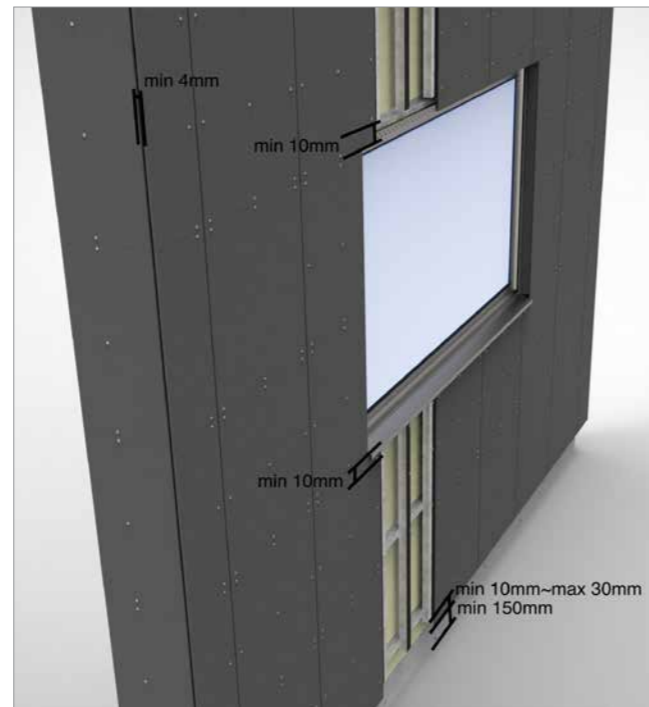

FIGURE 20.

GENERAL DISTANCES

CUT OUTS

To avoid cracking the Genesis façade boards when installing around windows, doors and other openings, ensure the boards are installed in accordance with the following instructions:

- Avoid cutting single, exact apertures in boards, rather to cut smaller sections and install them individually.
- Ensure that there is support behind the joints, onto which the façade board can be mounted.
- If the small cut outs are no wider than 150mm, they can be mounted with one rivet fixing in the middle of the board width (see Figure 13).



FIGURE 21. Correct installation of Genesis façade boards at windows, doors and openings
a: If the small cut-outs are not wider than 150mm, they can be mounted with only one rivet in the middle of the board.

Incorrect installation of Genesis façade boards at windows, doors and openings

PANEL FIXING

Genesis Façade Boards can be installed using Genesis Façade Rivets.

GENESIS FAÇADE RIVETS

Genesis Stainless Steel Rivets are to be used when fixing Genesis façade boards to steel top hats.

For all Fixing Positions, the Genesis Fixing Sleeves must be used. Insert the rivet into the Genesis Fixing Sleeve.

PRE-DRILLING BOARDS

For pre-drilling the Genesis boards it is recommended to use the Genesis Fibre Cement Drill Bit. This leaves you with the best results and the optimum number of drilled holes per drill bit. Dust from cutting or drilling must be removed immediately after the work has been completed, otherwise it can mark the surface of the boards.

The hole diameter is to be $\varnothing 9\text{mm}$.

TOP HATS

The Genesis top hats must be pre-drilled once the board is in the correct position. Pre-drill the top hats using a centring drill with a 4.9mm drill bit.

Pre-drilling the top hats using the centring tool ensures the rivet is fixed in the centre of the hole, allowing for movement of the board.

FIXING

The Stand-Off Head must be used on the rivet gun when fixing all Genesis Façade Rivets. This provides a small space between the board and the rivet head to allow for movement caused by moisture or temperature changes.

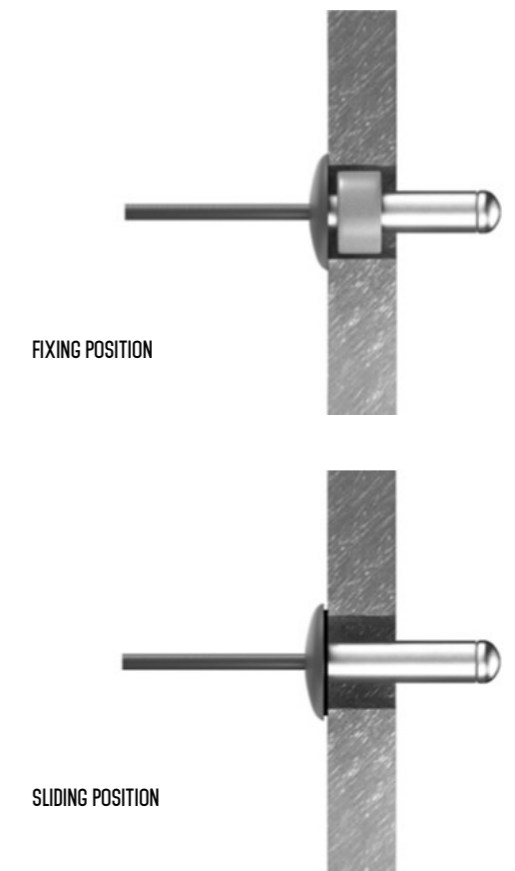

FIXING DETAIL

3D MODEL - VERTICAL JOINT

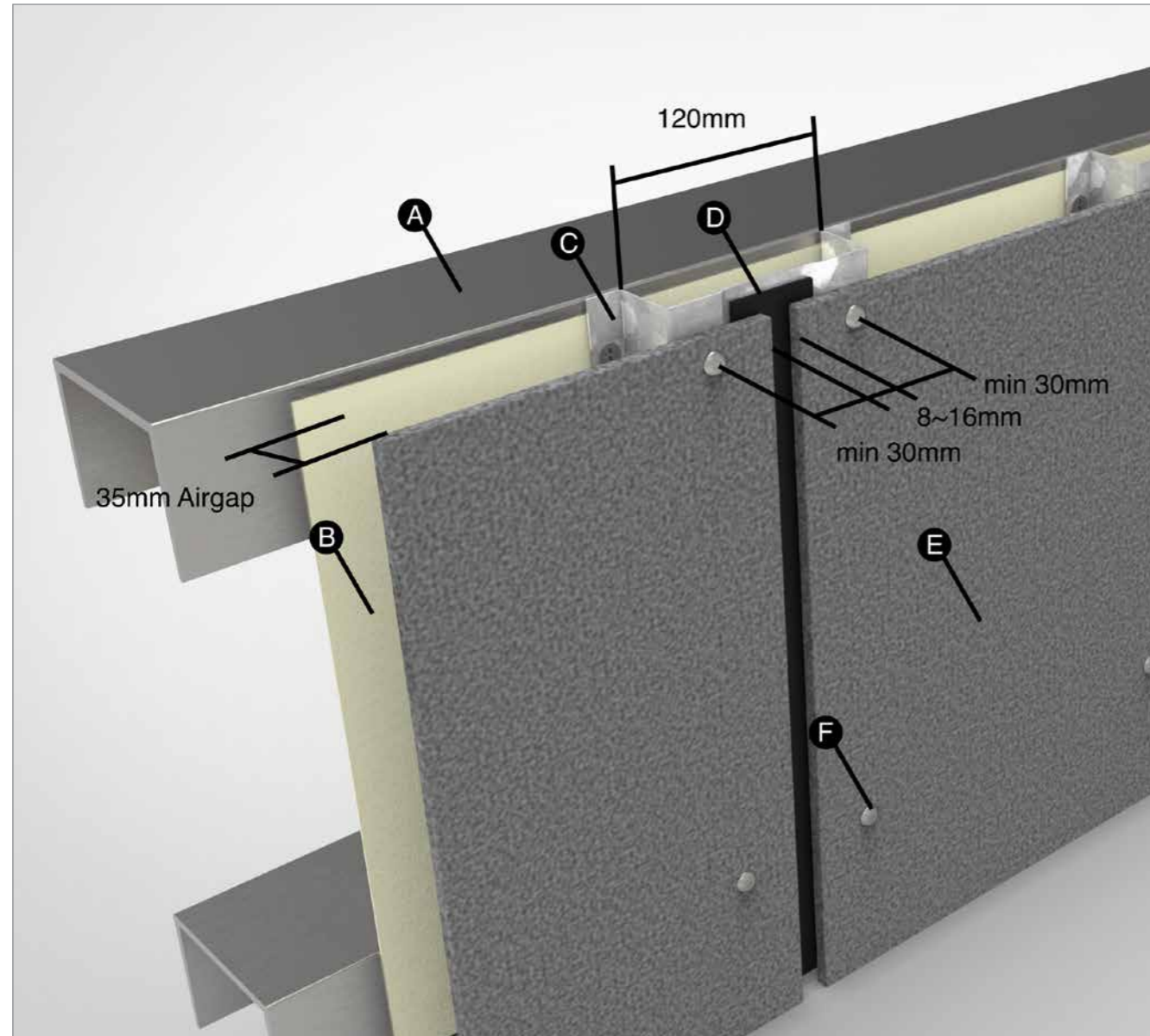

FIGURE 22.

- A. Steel Framing
- B. Vitrafix Sarking
- C. Genesis Joining Top Hat
- D. Genesis Gasket
- E. Genesis Façade Board
- F. Genesis Façade Rivet

FIXING DETAIL

VERTICAL CROSS SECTION - FOUNDATION

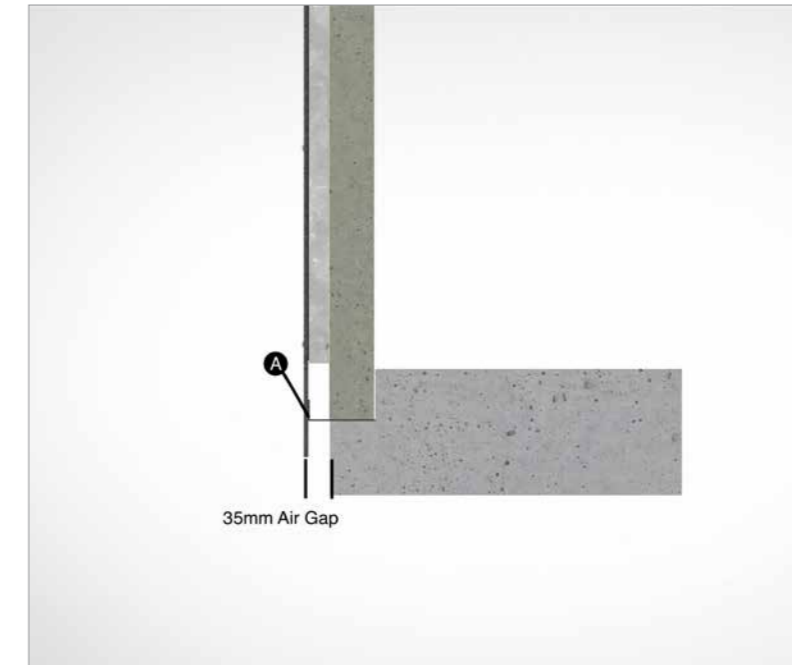

FIGURE 23.

- A. Anti-vermin perforated angle

3D MODEL - FOUNDATION



FIGURE 24.

- A. Anti-vermin perforated angle to sit flush against façade board

FIXING DETAIL

HORIZONTAL CROSS SECTION - EXTERIOR CORNER CLOSED JOINT

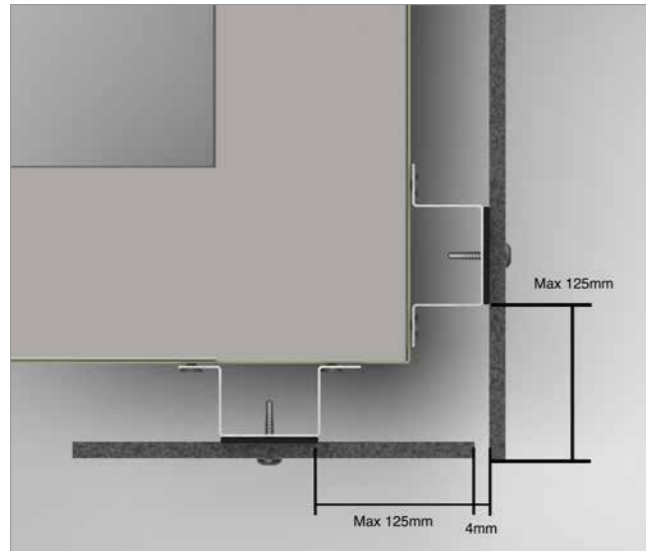

FIGURE 25.

HORIZONTAL CROSS SECTION - EXTERIOR CORNER CLOSED JOINT

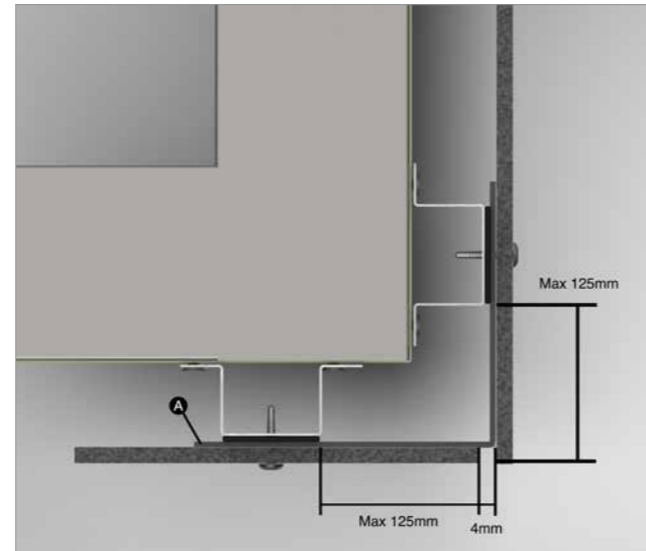

FIGURE 26.

A. Metal angle supplied by others (0.5mm)

HORIZONTAL CROSS SECTION - INTERIOR CORNER OPEN JOINT

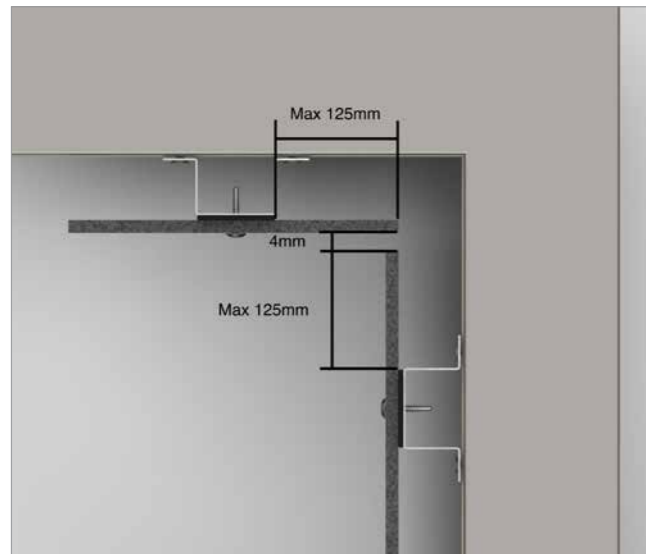

FIGURE 27.

HORIZONTAL CROSS SECTION - INTERIOR CORNER CLOSED JOINT

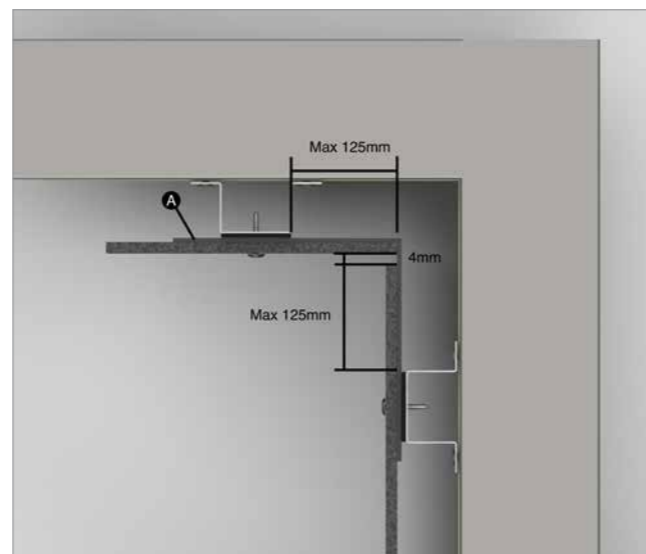

FIGURE 28.

FIXING DETAIL

VERTICAL CROSS SECTION - PARAPET

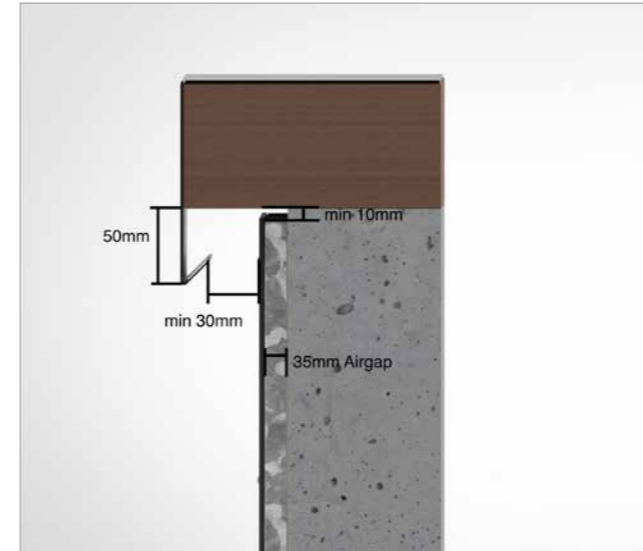

FIGURE 29.

3D MODEL - PARAPET

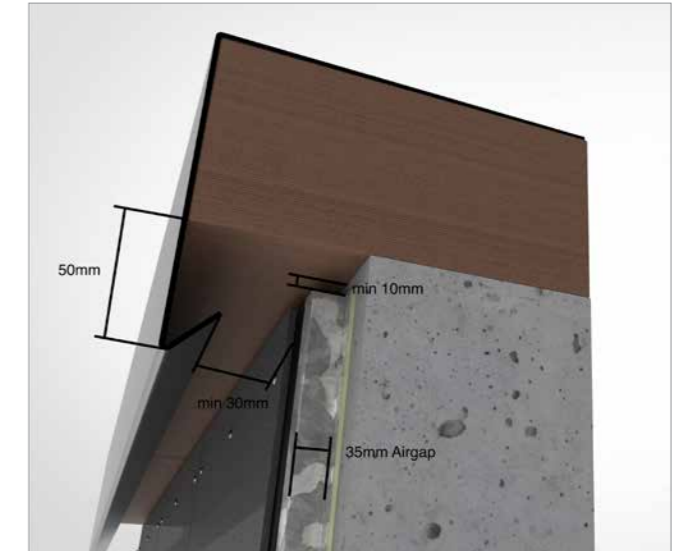

FIGURE 30.

HORIZONTAL CROSS SECTION - INTERIOR CORNER OPEN JOINT

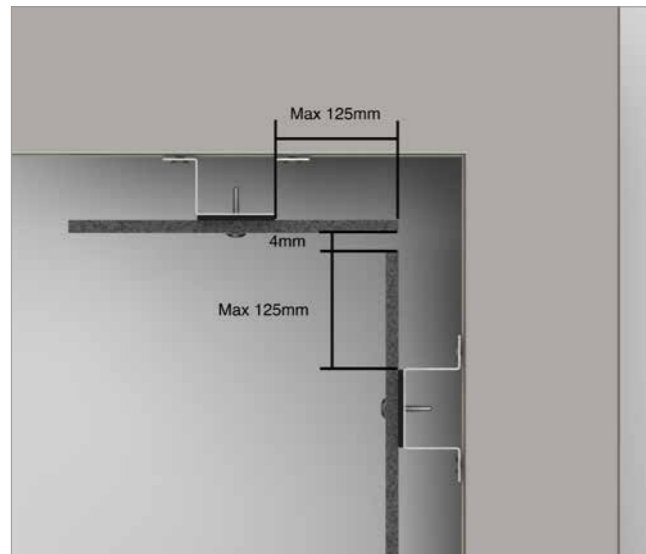

FIGURE 27.

HORIZONTAL CROSS SECTION - INTERIOR CORNER CLOSED JOINT

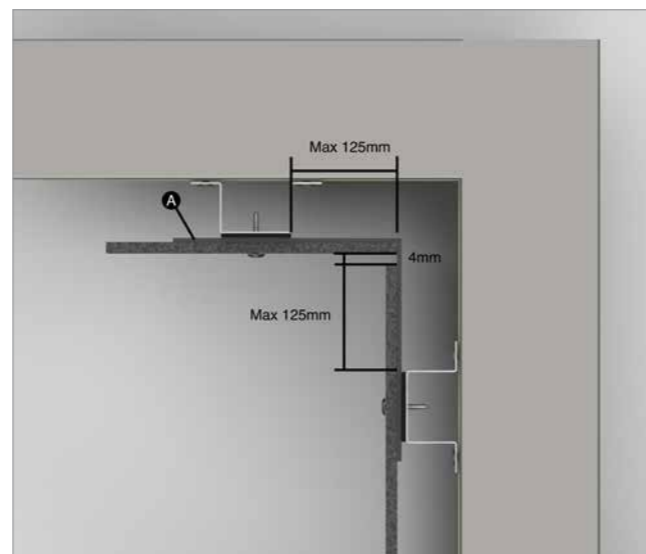

FIGURE 28.

VERTICAL CROSS SECTION SOFFIT

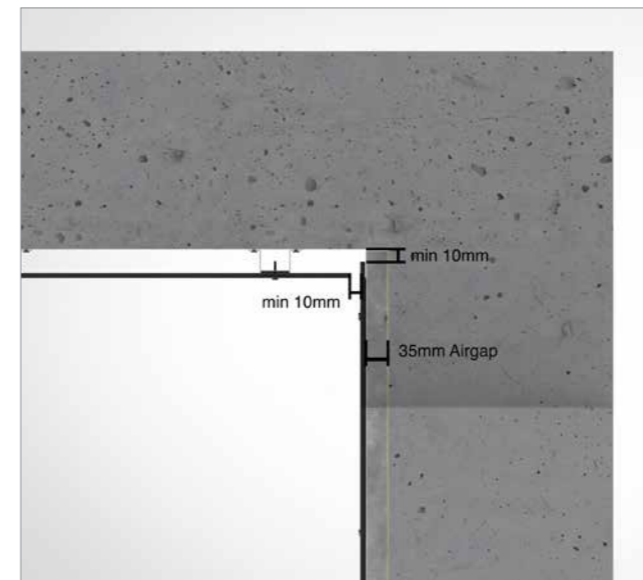

FIGURE 31.

3D MODEL - SOFFIT



FIGURE 32.

FIXING DETAIL

VERTICAL CROSS SECTION - WINDOW SILL

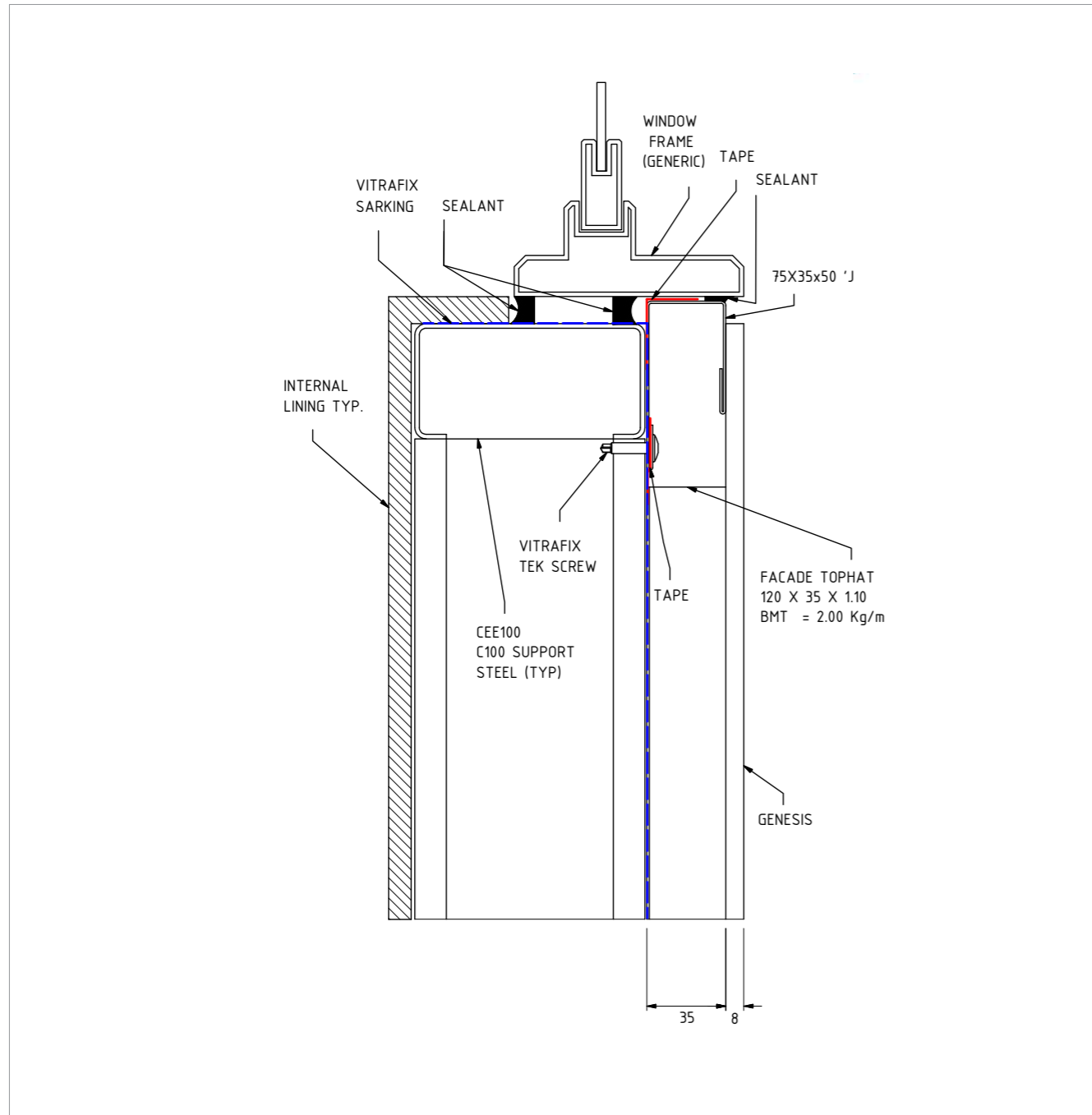

FIGURE 33.

FIXING DETAIL

VERTICAL CROSS SECTION - WINDOW SILL

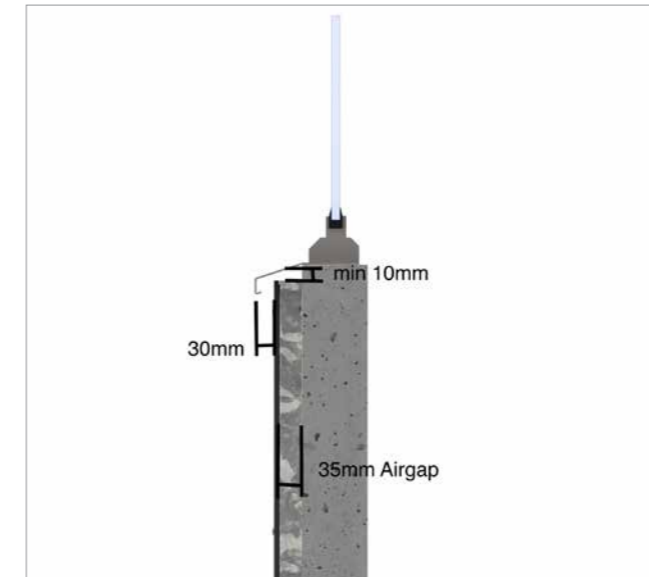

FIGURE 34.

VERTICAL CROSS SECTION - WINDOW HEAD

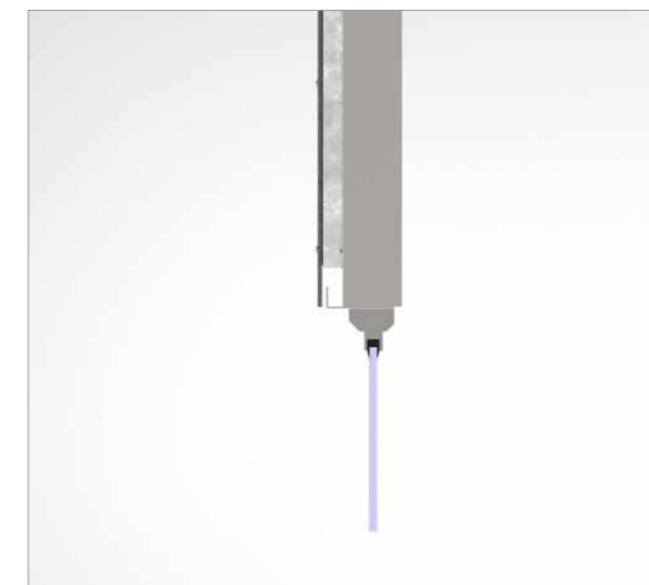

FIGURE 36.

3D MODEL - WINDOW SILL

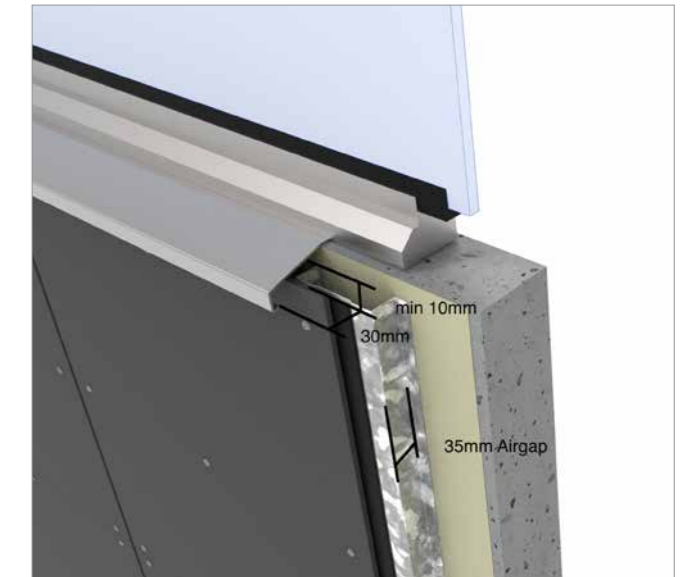

FIGURE 35.

3D MODEL - WINDOW HEAD

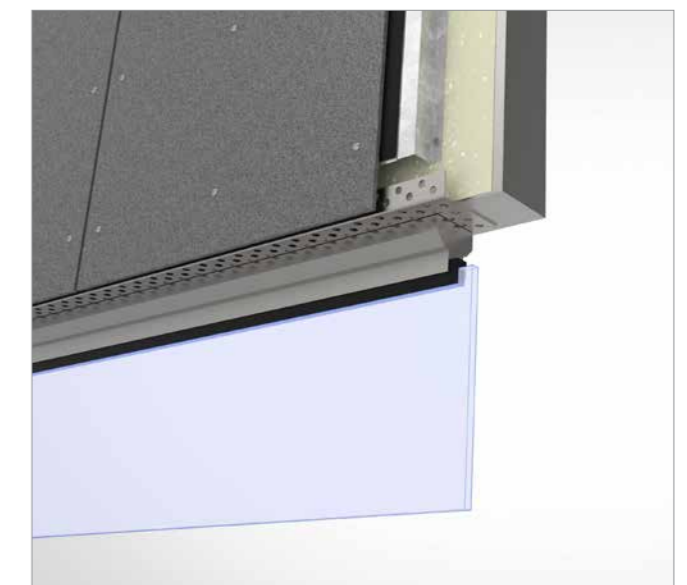

FIGURE 37.

FIXING DETAIL

3D MODEL - EXPANSION JOINT CLOSED JOINT

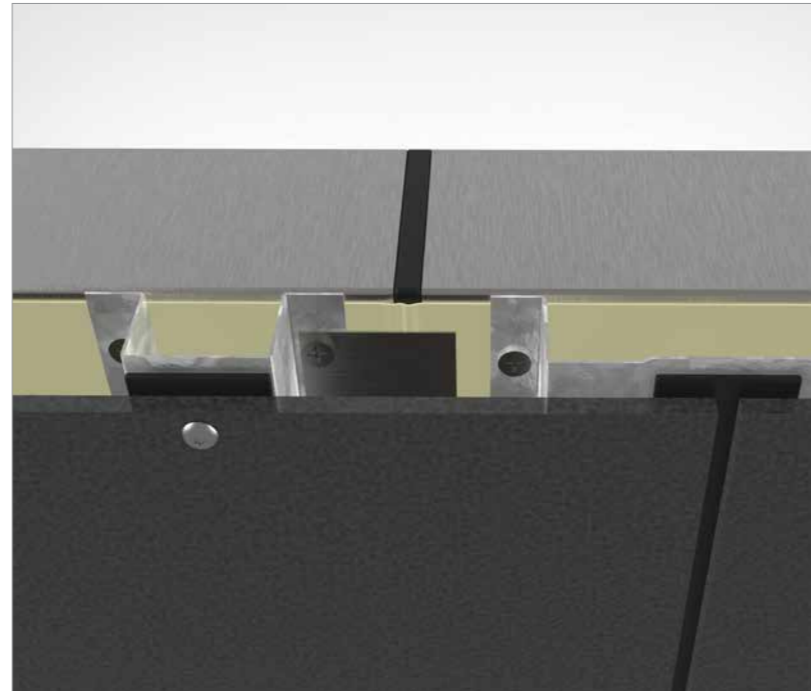

FIGURE 38.

VERTICAL CROSS SECTION - HORIZONTAL JOINT

- A. Steel Framing
- B. Vitrafix Sarking
- C. Genesis Intermediate Top Hat
- D. Genesis Façade Board
- E. Genesis 3.5mm Back Flashing

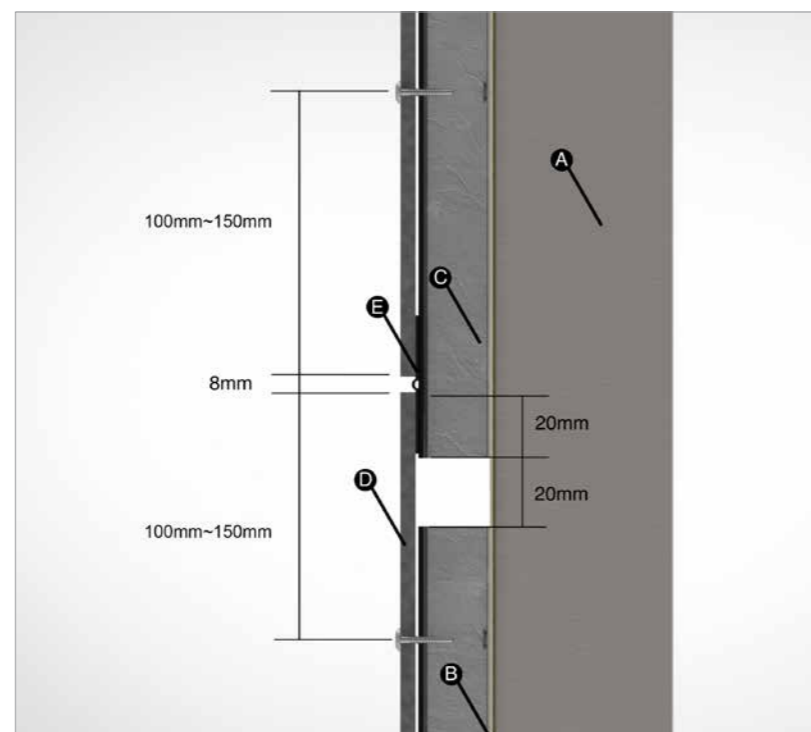

FIGURE 39.

CARE & MAINTENANCE

ANNUAL INSPECTION

Normally, a Genesis façade does not require maintenance to maintain its strength, properties and function. Environmental impacts may, however, influence the visual appearance of the façade. Therefore, an annual inspection of the surface, ventilation gaps, joints and fixings is recommended. Detection and repair of possible damages secure a prolonged lifetime for the façade.

CLEANING

Genesis façade boards can be cleaned with cold or lukewarm water, if necessary with the addition of a mild household detergent not containing solvents. Rinse with plenty of clean water until the façade is perfectly clean. Before cleaning full scale, it is recommended to test the selected cleaning method on a smaller area to ensure it works and does not damage the board surface.

WARNING: HIGH PRESSURE CLEANING IS NOT RECOMMENDED AS IT MAY DAMAGE THE SURFACE.

MOSS AND ALGAE

Moss and algae growth can be removed with common detergents available on the market. Care should be taken to ensure that the cleaning agent does not cause damage to the surface of the Genesis façade boards. Confirm the compatibility of your cleaning agent with your cleaning agent supplier, and ensure it is applied according to the supplier's instructions. It is advised that before conducting a large-scale application a test is carried out on a small, inconspicuous area to ensure that the cleaning agent has no effect on the colour of Genesis façade boards.

EFFLORESCENCE

Efflorescence is a naturally occurring, white, powdery deposit that can appear on cement-based building materials (including bricks, cement walls, grout, and fibre cement). It is the result of a process in which moisture draws salt crystals to the surface, evaporates, and leaves a chalky substance behind.

Efflorescence occurs when all three of the following conditions exist:

1. Water-soluble salts are present in the building material.
2. There is enough moisture in the wall to turn the salts into a soluble solution.
3. There is a path for the soluble salts to get to the surface.

Efflorescence may also be a sign of water ingress behind the façade. Make certain that all openings are properly covered. While some efflorescence may weather away naturally on its own, it is best to take steps to treat it. Efflorescence can be removed with household white vinegar and water. For most cases of efflorescence, Step 1 - 3 works well. But for substantial deposits of efflorescence go to Step 4.

For best results, follow these cleaning instructions:

1. Protect areas that are not to be cleaned. Rinse all plants and vegetation around the façade with water before and after application of the vinegar.
2. Generously coat the entire surface area with vinegar. Allow the solution to sit on the surface for 10 minutes.
3. Rinse the treated area thoroughly with water from the top down and allow the area to air dry.
4. For extra tough efflorescence: Use a 10% acetic acid solution and apply to affected area with cotton cloth. A light scrubbing with the cotton cloth may be required. After about 20 seconds rinse with water.



FAIRVIEW™

DEFINING ARCHITECTURE SINCE 1988



AUSTRALIA
NEW ZEALAND
UNITED KINGDOM

SALES ENQUIRIES 1800 007 175

HELPDESK@FV.COM.AU

FV.COM.AU

GENESIS INSTALLATION MANUAL / NOVEMBER 2023