

14/12/2023

FVA Group Pty Limited
18-20 Donald Street
Lithgow, NSW, 2790

Attn: **Greg Wala**
By email: greg.wala@fv.com.au

Structural Design Certification

50 mm x 24 mm x 1.15 mm BMT
50 mm x 35 mm x 1.15 mm BMT
Perforated G2 Z275 Steel Tophat

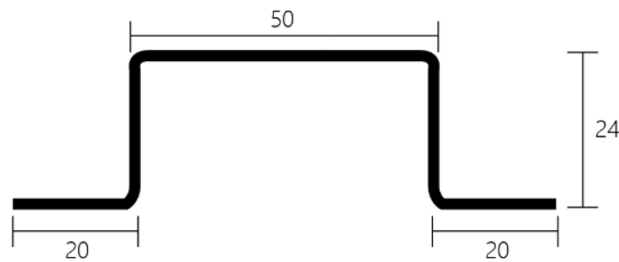

50x24x20mm Top Hat - Ø12mm holes with 44mm centres spacings

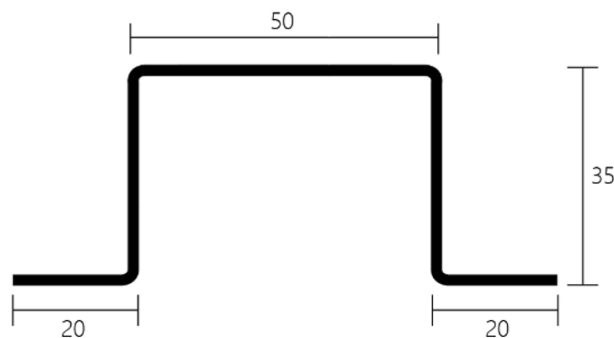

50x35x20mm Top Hat - Ø20mm holes with 72mm centres spacings

This is to confirm that the 50 mm x 24 mm x 1.15 mm BMT and 50 mm x 35 mm x 1.15 mm BMT perforated G2 Z275 steel tophat span table attached has been developed by the undersigned to comply with the requirements of the National Construction Code (NCC 2022) for structural adequacy. The tables were originally produced for 1.1 mm BMT G250 material feed, and is therefore acceptable for the variation to 1.15 mm BMT G2 or 1.2 mm BMT G2 material feed.

The reference material standard is AS/NZS 4600:2018 Cold-formed steel structures, and the structural analysis was carried out using accepted engineering principles to safely withstand ultimate and serviceability wind pressures to be determined by the building designer in accordance with AS/NZS 1170.2:2021 Structural design actions – Part 2: Wind actions, or AS 4055:2021 Wind loads for housing, for the building importance level as per NCC Volume One Part B1 Structural Provisions.

The sizing and spacing of the holes has been determined within limitations that do not require special modification of span tables from the full section within the normal specifications. Ends of tophats shall be the full section at the support.

Irrespective of the presence of perforations in the tophat, a fire break at the storey junction and at separation walls between slab edge and the back side of cladding is necessary at every level and between sole occupancy units.

Please contact the undersigned if you have any queries regarding this document.

Yours sincerely,
Enertren Pty Ltd



John Trenergy BE MEM MIEAust CPEng NER (471275)
RPEng (Structural): NSW – PRE0000453; Queensland – 21047; Victoria – PE0005235
Design Practitioner Registration (Façade, Structural Engineering): NSW – DEP0000453

Appendix A – 50 mm x 24 mm x 1.15 mm BMT Perforated Tophat Span Table

Appendix B – 50 mm x 35 mm x 1.15 mm BMT Perforated Tophat Span Table

Appendix C – Perforated Tophat Drawing

Appendix D – Fairview Perforated Tophat Drawing

Document Control

Date of Issue	Version	Filename	Change Summary
17/11/2023	V.0	FAR-126 Perforated Tophat 231117 V.0	Draft version.
7/12/2023	V.1	FAR-126 Perforated Tophat 231207 V.1	Final version.
14/12/2023	V.2	FAR-126 Perforated Tophat 231214 V.2	Material specification changed to 1.15 mm BMT G2.



Appendix A – 50 mm x 24 mm x 1.15 mm BMT G2 Perforated Tophat Span Table

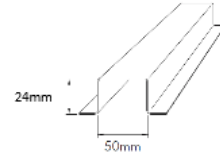

Design Wind Pressure		Maximum Tophat Spacing (mm) - 50 x 24 x 1.1 mm BMT G250								
ULS, W ₀ (kPa)	SLS, W _s (kPa)	Tophat Span / Support Spacing (mm)								
		300	400	450	600	900	1200	1500	1800	2100
1.00	0.68	2000	2000	2000	2000	1750	740	370	200	130
1.50	1.01	2000	2000	2000	2000	1160	490	250	140	NS
2.00	1.35	2000	2000	2000	2000	870	370	180	NS	NS
2.50	1.69	2000	2000	2000	1600	700	290	150	NS	NS
3.00	2.03	2000	2000	2000	1340	580	240	NS	NS	NS
3.50	2.37	2000	2000	1800	1140	500	210	NS	NS	NS
4.00	2.70	2000	1880	1570	1000	430	180	NS	NS	NS
4.50	3.04	2000	1670	1400	890	390	160	NS	NS	NS
5.00	3.38	2000	1510	1260	800	350	140	NS	NS	NS
5.50	3.72	2000	1370	1140	730	310	130	NS	NS	NS
6.00	4.06	1920	1250	1050	670	290	NS	NS	NS	NS
6.50	4.39	1770	1160	970	610	270	NS	NS	NS	NS
7.00	4.73	1650	1070	900	570	250	NS	NS	NS	NS
7.50	5.07	1530	1010	840	530	230	NS	NS	NS	NS
8.00	5.41	1440	940	780	500	200	NS	NS	NS	NS
8.50	5.75	1350	880	740	470	200	NS	NS	NS	NS
9.00	6.08	1280	830	700	440	190	NS	NS	NS	NS

NS = Not Suitable

Screw fixing key: 2 x No.10 2 x No.12 2 x No.14 4 x No.12 (minimum specification)

- Notes:**
- Table data based on tophats having a minimum of 3 continuous spans.
 - Tophat shall be minimum thickness 1.1 mm BMT, minimum grade G250, and minimum coating Z275, AZ150 or AM150.
 - Serviceability wind pressure (SLS, W_s) is based on a recurrence interval of 25 years in Region A, factored against a recurrence interval of 500 years for ultimate wind pressure (ULS, W₀). Refer to AS/NZS 1170.2 Table 3.1.
 - Table based on uniformly distributed line loading along tophat. For discreet fixing of sheets or cassettes to tophats, this is assumed to be acceptable for fixing centres less than 300mm or the tophat span divided by 4, whichever is the
 - Self-drilling hex head screws shall be in accordance with with AS3566 Parts 1 and 2.
 - Connection design based on AS/NZS 4600:2018. Purlin substrate shall be minimum 1.2mm BMT, G500 cold-formed steel. Minimum distance of centreline of screw to edge of tophat shall be 1.5d, as follows:
 No.10 : e = 7.2 mm No.12 : e = 8.3 mm No.14 : e = 9.5 mm
 - Capacity of screws in pullout from the tophat is as follows (calculated in accordance with AS/NZS 4600:2018 Section
 No.10 : 0.718 kN No.12 : 0.822 kN No.14 : 0.942 kN



Appendix B – 50 mm x 35 mm x 1.15 mm BMT G2 Perforated Tophat Span Table



FAIRVIEW

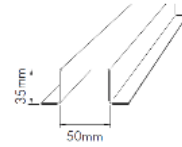

Design Wind Pressure		Maximum Tophat Spacing (mm) - 50 x 35 x 1.1 mm BMT G250								
ULS, W_u (kPa)	SLS, W_s (kPa)	Tophat Span / Support Spacing (mm)								
		300	400	450	600	900	1200	1500	1800	2100
1.00	0.68	2000	2000	2000	2000	2000	1910	1260	730	460
1.50	1.01	2000	2000	2000	2000	1970	1270	840	480	300
2.00	1.35	2000	2000	2000	2000	1480	950	630	360	230
2.50	1.69	2000	2000	2000	2000	1180	760	500	290	NS
3.00	2.03	2000	2000	2000	1770	980	630	420	240	NS
3.50	2.37	2000	2000	2000	1520	840	540	360	200	NS
4.00	2.70	2000	2000	1960	1330	740	470	310	NS	NS
4.50	3.04	2000	2000	1740	1180	660	420	280	NS	NS
5.00	3.38	2000	1830	1570	1060	590	380	250	NS	NS
5.50	3.72	2000	1660	1420	960	540	340	230	NS	NS
6.00	4.06	2000	1520	1310	880	490	310	210	NS	NS
6.50	4.39	2000	1410	1200	810	450	290	NS	NS	NS
7.00	4.73	1880	1310	1120	760	420	270	NS	NS	NS
7.50	5.07	1750	1220	1040	700	390	250	NS	NS	NS
8.00	5.41	1640	1140	980	660	370	230	NS	NS	NS
8.50	5.75	1540	1070	920	620	340	220	NS	NS	NS
9.00	6.08	1460	1010	870	590	330	210	NS	NS	NS

NS = Not Suitable

Screw fixing key: 2 x No.10 2 x No.12 2 x No.14 4 x No.12 (minimum specification)

- Notes:**
- Table data based on tophats having a minimum of 3 continuous spans.
 - Tophat shall be minimum thickness 1.1 mm BMT, minimum grade G250, and minimum coating Z275, AZ150 or AM150.
 - Serviceability wind pressure (SLS, W_s) is based on a recurrence interval of 25 years in Region A, factored against a recurrence interval of 500 years for ultimate wind pressure (ULS, W_u). Refer to AS/NZS 1170.2 Table 3.1.
 - Table based on uniformly distributed line loading along tophat. For discreet fixing of sheets or cassettes to tophats, this is assumed to be acceptable for fixing centres less than 300mm or the tophat span divided by 4, whichever is the
 - Self-drilling hex head screws shall be in accordance with with AS3566 Parts 1 and 2.
 - Connection design based on AS/NZS 4600:2018. Purlin substrate shall be minimum 1.2mm BMT, G500 cold-formed steel. Minimum distance of centreline of screw to edge of tophat shall be 1.5d, as follows:
 No.10 : e = 7.2 mm No.12 : e = 8.3 mm No.14 : e = 9.5 mm
 - Capacity of screws in pullout from the tophat is as follows (calculated in accordance with AS/NZS 4600:2018 Section
 No.10 : 0.718 kN No.12 : 0.822 kN No.14 : 0.942 kN



Appendix C – Perforated Tophat Drawing

50x24x20mm TOPHAT 1.2mm BMT

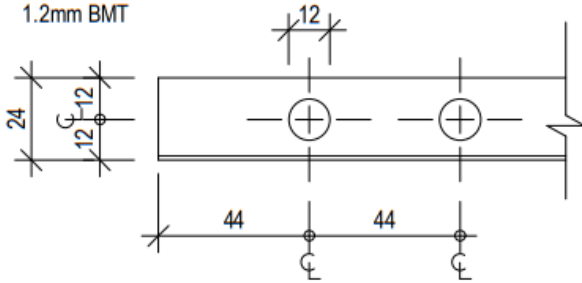

50x35x20mm TOPHAT 1.2mm BMT

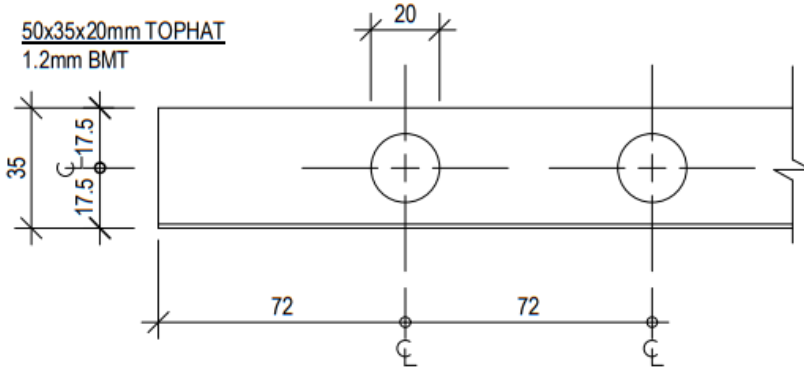

1 TOPHAT DETAILS SCALE: 1 : 2

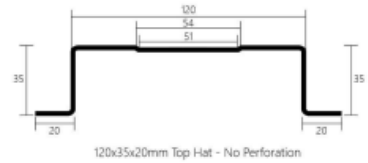
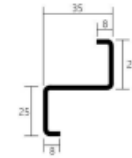
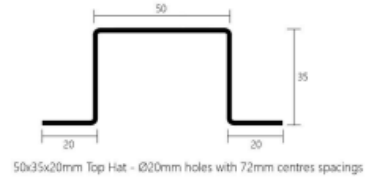
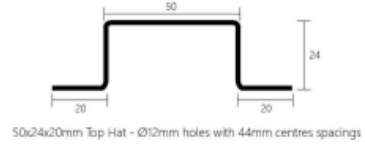
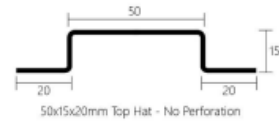

CERTIFIED	ENGINEERING CONSULTANTS	CLIENT	FAIRVIEW	
	ENERTREN PTY LTD	PROJECT		
JOHN TRENERRY BE MEMMIEAust CPEng NER	ABN: 75 770 323 635 www.enertren.com.au P: (02) 8005 4766 PO Box 312, Bathurst, NSW, 2795	LOCATION	DATE	ISSUE
		DRAWING TITLE	17/11/2023	
		TOPHAT PENETRATION DETAILS	PROJECT NO.	
			FAR-126	

Appendix D - Fairview Perforated Tophat Drawing

