



FAIRVIEW™

DEFINING ARCHITECTURE SINCE 1983



smartbric®

BRICK RAINSCREEN FAÇADE SYSTEM / MANUFACTURED BY FAIRVIEW

INSTALLATION MANUAL

ABOUT THIS GUIDE

This manual has been developed as an effective installation resource to inform designers, fabricators and contractors when specifying and working with the Fairview Smartbric® Rainscreen Façade System.

The guide will provide easy to follow installation information. As uncontrollable conditions of the job scope alter, this guide is a comprehensive resource for users. Fairview recommends seeking the advice of a professional where required prior to installation.

In no way does this Installation Manual replace the services of the building design professionals, nor is it an exhaustive guide of all possible scenarios. It is the responsibility of the building design professional, including the project Certifier, to ensure that the details in this Technical Manual are appropriate for the intended application.

The information and recommendations contained herein are believed to be correct at time of publishing. Fairview reserve the right to revise the contents of this manual.

For additional information and assistance with the Smartbric system, please contact Fairview on helpdesk@fv.com.au.

CONTENTS

Introduction	5
Product Features and Benefits	6
Smartbric System Overview	12
Engineering Compliance and Structural Specifications	19
General Assembly	22
Design and Selection	34
Durability	42
Smartbric General Layout and Cutting	58
Smartbric Classic and Track Installation - Overview	69
Warranty	122

DISCLAIMER

The information contained in this publication and otherwise supplied to users of Smartbric products is based on Fairview's general experience, best knowledge and belief. However, due to factors which fall beyond Fairview's knowledge and control, which can affect the use of the products, no warranty is given, express or implied with respect to fitness for particular purpose or otherwise.

It is the responsibility of the architect, designer and various engineering parties to ensure that the details in this Installation Manual are appropriate for the intended application.

Fairview reserves the right to alter specifications at any time and without notice. Products are subject to natural variation as part of the manufacturing process, colours and textures may vary according to light and weather conditions. Due to this and limitations of the printing accuracy, colours in this brochure may vary. In case of doubt, please contact your local Fairview representative.



INTRODUCTION

ABOUT SMARTBRIC® RAINSCREEN BRICK FAÇADE SYSTEM

Smartbric by Fairview is an innovative Ventilated Rainscreen Brick Facade System which ingeniously incorporates the option of a grouted Classic brick facing or a modern Rapid mortar-less brick facing in combination with either a unique mounting track or universal rail option to deliver a versatile natural looking masonry façade solution.

The Smartbric Classic and Rapid brick listels are secured into position using dual locking mechanism capturing both the top and bottom of the listel (brick facing unit). Smartbric Classic is designed to be finished off using a mortar to deliver a flush finish brick look whereas the Smartbric Rapid is designed as a mortar-less system. The Rapid brick's recessed edges provide a shadow effect that replicated the look and character of brickwork with a raked joint. The Smartbric Rapid can also be grouted if desired.

The system has been tested to AS4284 and developed for quick, smart, and simple installation by skilled tradesmen as well as traditional bricklayers. Made using either vitrified clay or concrete masonry, Smartbric allows the designer to achieve a realistic brick look without the shortcomings or restraints of traditional brickwork when it comes to weight, limited space or where traditional brick construction is not economically viable.

Smartbric meets the necessary requirements of the National Construction Code (NCC) of Australia, is durable, weather resistant, non-combustible and structurally sound for its intended applications, being residential medium density buildings and fit outs.

PRODUCT FEATURES

PRODUCT DNA

Light Weight Ventilated Rainscreen Brick Façade System

FINISH

Vitrified Clay and Concrete Masonry Brick Listels (Facings)

FIXING SYSTEM

Dual Top and Bottom Grooved (Classic) and Ship-Lapped (Rapid) Brick-Slip Unit with Interlocking Tongue and Groove arrangement to engage with Roll-formed Metal Track or Extruded Rail

APPLICATION

Type A, B and C construction where non-combustible materials or brick appearance are required such as mixed-use developments, residential construction, commercial and shopfitting projects

WARRANTY

10 year standard warranty, subject to terms and conditions

UNIQUE FEATURES AND BENEFITS:

Smartbric is suitable for exterior and interior applications as well as new buildings and renovations. Facings are available in a range of colours and can also be made to custom colours and textures (subject to lead times and minimum order quantities), to allow any number of colour combinations and expression of design.

A modern, sleek and sharp look can be effectively achieved by incorporating complimentary trim for corners and surrounds as well as pre-mixed polymer modified coloured mortar to blend-in or accentuate the pointing.

Smartbric facings are manufactured in standard sizes to reflect the common Australian brick size of 230mm x 76mm. Brick facings are designed to be cut onsite using a conventional wet brick saw to suit the specific measurement the job requires.

The Smartbric Brick, Track and Rail system complies with the relevant requirements of Section B National Construction Code (NCC) Volume 1 and Section 2 NCC Volume 2.

This Installation Manual is designed to assist building and design professionals with the detailing, specification and installation of the Smartbric Rainscreen Brick Façade system.

FINAL DESIGN AND CERTIFICATION OF ALL ELEMENTS TO THE INSIDE OF THE SMARTBRIC RAIL/TRACK TO BE CARRIED OUT BY THE PROJECT DESIGN PROFESSIONAL.

TRACK AND RAIL ECO-SYSTEM

- Innovative design with interchangeable Track and Rail



- Design and creative flexibility - grouted or mortarless shadow look



SMARTBRIC RAPID

SMARTBRIC CLASSIC

- Dual locking '2 x 2 Bric-Loc' mechanism (brick facings locked into track or rail on both the top and bottom of the unit- 2 brick types x 2 mounting types)



- Concealed mounting system
- Fixed gauge roll-formed steel track (for fast and simple installation)



- Extruded aluminium rail (for greater design flexibility or where greater durability is required)

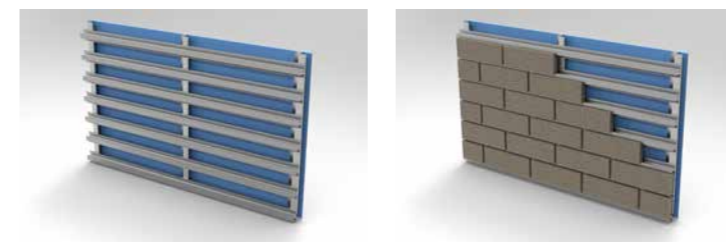

CLASSIC BRICK FACINGS

- Delivers a classic mortared brick look
- Adaptable for local brick-stock
- Installed with traditional mortar or polymer modified high-bond mortar



RAPID MORTAR-LESS BRICK FACINGS

- Delivers speed and efficiency
- Shadow-line mortar effect – without the mess and cost of pointing
- Modern Rainscreen façade system
- Removable and replaceable facings

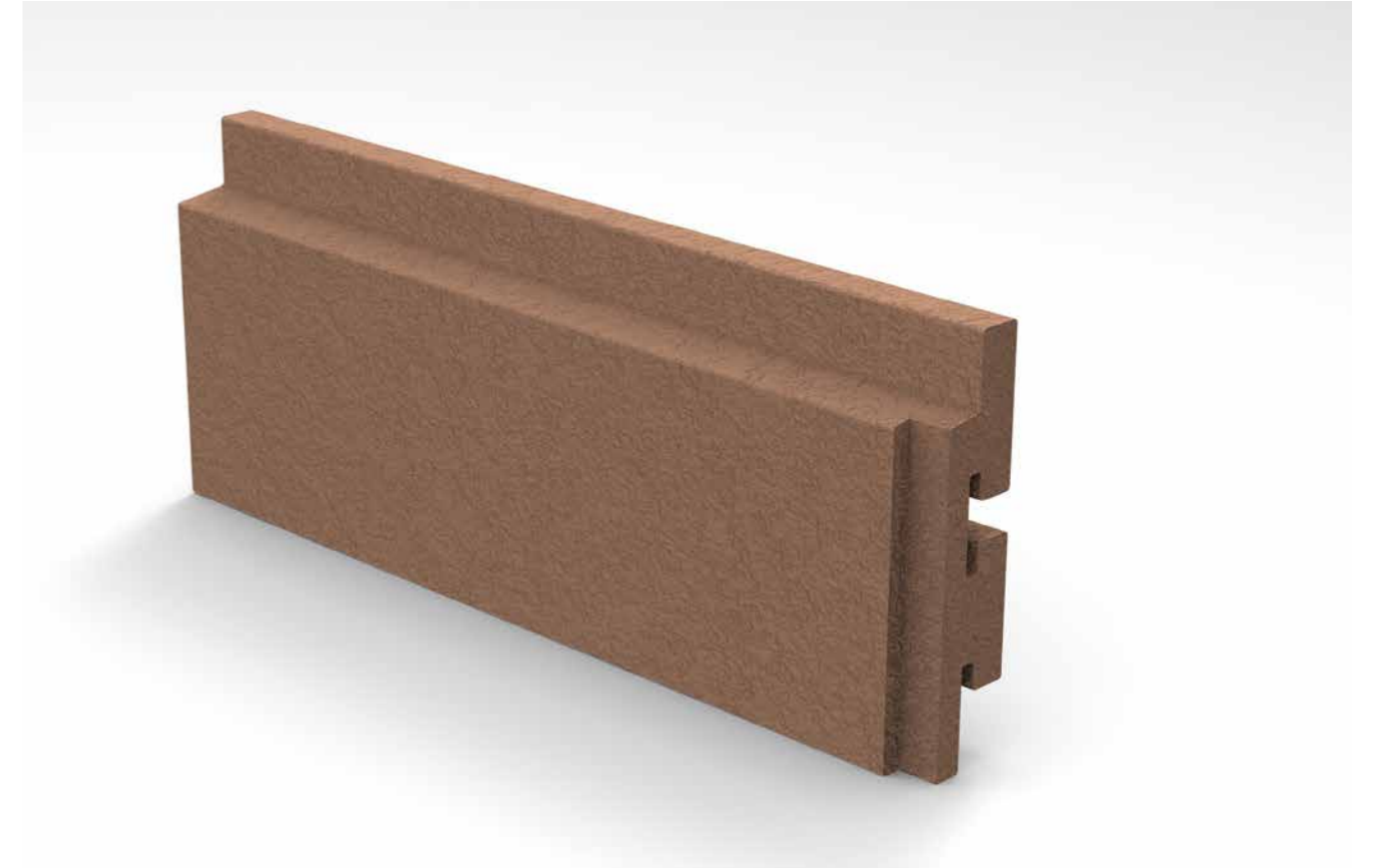

SMARTBRIC CLASSIC STYLE

- 25mm Commercial Range – Australian Made (Custom also available on request/MOQ apply)



- 25mm Commercial Imported Range – Made to Order



- 25mm Commercial Local Concrete Masonry Range – Australian Made Custom also available on request/MOQ apply)



SMARTBRIC RAPID STYLE

- 25mm Commercial Mortar-less Imported Range – Made to Order

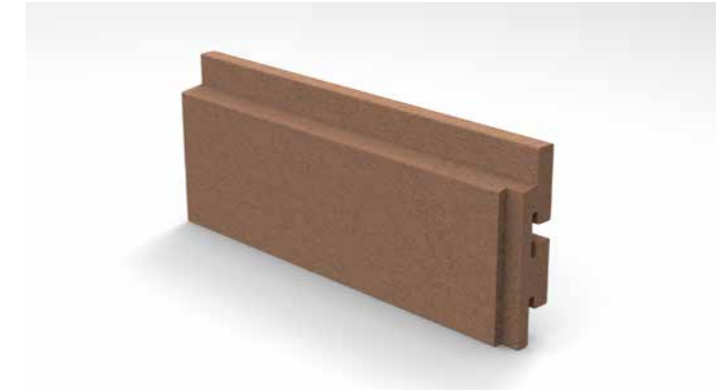

Note: Colours shown are indicative only and should not be used for final selection. Products chosen and ordered should be selected from actual samples at time of order. Clay bricks are made from naturally occurring minerals and position in firing kiln will also influence colour. Some variation in concrete brick colour, aggregate colour, aggregate size, and other components may occur. Variations in colour, texture, and size are natural characteristics of clay and concrete mix and production variations can occur from batch to batch. It is recommended to order all product requirements at the same time to avoid batch to batch variation.

BLENDING BRICKS

It is not uncommon to have variation of colour and tone from pack to pack and even within a pack, depending on how the bricks are produced and the nature of the raw ingredients. It is very important to blend all our packs of bricks together.

When the product is delivered on site, it is very important for the bricks to be "grouped" around the worksite for the brick contractors to obtain access to an even blend of product. Grouping will ensure easy access to the full range of colour within the product. If this process is not performed, the risk of colour variation or a banding effect is greatly increased. To ensure an even blend, it is important that you blend all your bricks together and it is best not to start your brickworks until all, or most of your bricks are on site.



Special brick blends are also popular whereby different brick types are specifically combined to achieve a particular look such as the "Federation Blend" illustrated above. This blend is made up using: 1/3 Federation Black : 1/3 Federation Blue : 1/3 Federation Red.

MORTAR COLOUR

Different mortar colour can dramatically change the appearance of a brick. Choose your mortar colour with care; as other mortar colours will highlight and contrast your bricks, while some mortars will tone down your brickwork.



SMARTBRIC SYSTEM OVERVIEW

SIMPLE INSTALLATION

Fixed gauge profiled galvanised steel track with Classic brick facing or Rapid brick facing



STEP 1. STACK



STEP 2. IN-FILL



STEP 3 GROUT (OPTIONAL)

VARIABLE GAUGE PROFILED ALUMINIUM RAIL WITH CLASSIC BRICK FACING OR RAPID BRICK FACING



STEP 1. STACK



STEP 2. IN-FILL



STEP 3 GROUT (OPTIONAL)

STEP 1. STACK

- Fixed gauge interlocking profiled steel track are fixed to backing structure with vertical supports at 600mm maximum centres
- OR
- Variable gauge aluminium rails are fixed to backing structure with vertical supports at 600mm maximum centres

STEP 2. IN-FILL

- Smartbric facings are locked into position
- Track and rail designed to capture and secure brick facing
- Perpend joint spacers inserted (where required)

STEP 3. GROUT

- Mortar applied (where required)
- Joints finished – flush or ironed mortar joints recommended

SYSTEM COMPONENTS

System comprises of the following components:

1. Brick Facings – Brick facings are made from genuine brick cuttings or specially manufactured and profiled fired clay which when installed deliver the genuine appearance, colour and texture of a real clay brick wall.
 - 25mm Classic brick facing
 - 25mm Rapid brick facing



2. Framing System – A uniquely profiled track and rail mounting eco-system incorporating a dual locking mechanism to secure bricks brick facings in position.

- Smartbric 86mm fixed gauge interlocking profiled galvanised steel track
- Smartbric variable gauge aluminium rail

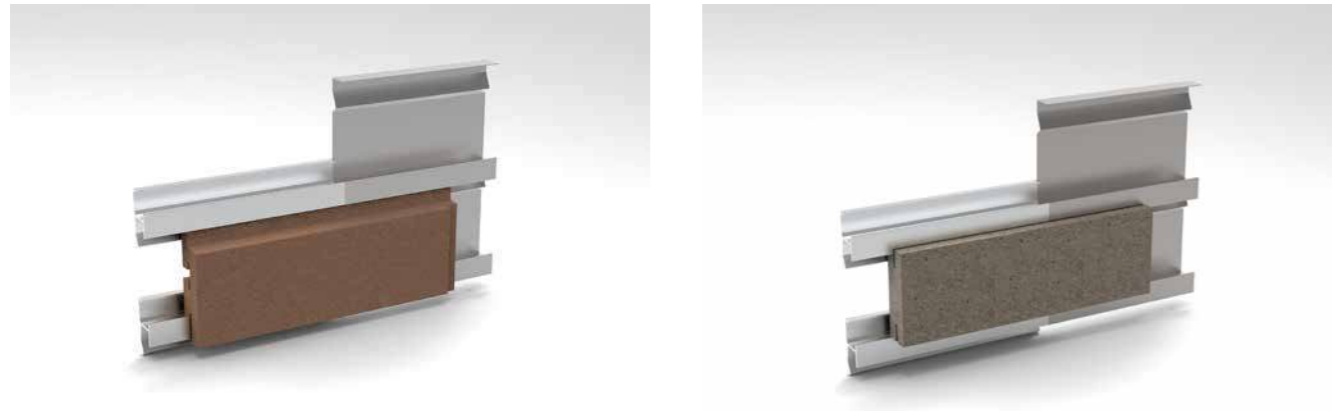
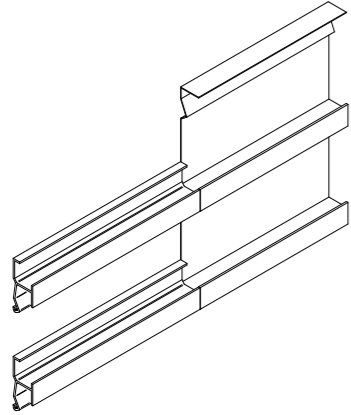

3. Backing Structure / Moisture Barrier – A weather defense system tested to AS4284 incorporating a proprietary S-batten for supports up to 600mm maximum centres

- 35mm S-Section Batten
- Flexible Weatherseal Membrane and Accessories

4. Mortar – Brick grouting for decorating and sealing between bricks to provide weatherproofing and authentic feel and look of brick work.

- Smartbric Redi-Mix Polymer Modified Mortar
- Smartbric Add-Mix (mortar additive)

5. Finishing Trim – Decorative aluminium extrusions for detailing trim and to accentuate design quality of finish.

- External Corner Trim
- Internal Corner Trim
- J-Section Cover Mould

ADVANTAGES OF THE SMARTBRIC - BRICK RAINSCREEN FAÇADE SYSTEM

AVOIDS CONDENSATION AND HUMIDITY

The continuous circulation of air inside the air cavity works as an extra protection layer and removes the possible water filtrations that can slip through the cladding joints

DURABILITY - EXTENDS THE FAÇADE'S LIFETIME

The ventilation inside the air cavity improves the durability of the exterior cladding material, since it keeps it dry. Precipitation and atmospheric moisture are removed from the surface of the façade in a natural way.

ALL-WEATHER INSTALLATION

The absence of "wet" (mortar) processes allows Smartbric Rapid to be installed all year round, at any temperature and humidity, so construction delays can be minimised. Where the "wet" process is used with the Smartbric Classic, the use of the Smartbric Redi-Mixed polymer modified mortar provides a fast surface skin resistant to light-showery rain.

ENVIRONMENTAL FRIENDLINESS

Smartbric brick products are made in compliance with all requirements for environmental safety and exclusively from natural raw materials or high content recycled material, so the degree of environmental friendliness it is on a par with such natural materials as stone and wood.

EASE OF INSTALLATION

Thanks to the unique eco-system design of the sub-system and configuration of the decorative cladding elements through to the smallest detail, the installation process is made as simple and intuitive as possible.

REDUCES STRUCTURAL MOVEMENTS

The more stable temperature in the construction envelope helps preventing the risk of cracks and other structural issues

UV RESISTANCE

The natural ingredients that make up the Smartbric clay listels and the firing process locks in the colour so they do not fade in the sun and will look great for years.

INCREASES ENERGY EFFICIENCY

Rainscreen cladding makes cooling the building easier in summer and provides a better control of the heating during winter, favouring both thermal comfort and energy saving.

FIRE RESISTANCE

Smartbric brick units are made from vitrified clay or concrete and are inherently non-combustible. You could say that each clay brick is individually tested during the firing process.

AESTHETICS

Structurally set horizontal and vertical seams of the same width give the facade a beautiful clearly defined pattern of ideal brickwork. The richness of shades and textures of Smartbric facings, as well as the possibility of using three-dimensional decorative and trim elements allows for implementation of architectural ideas of any complexity.

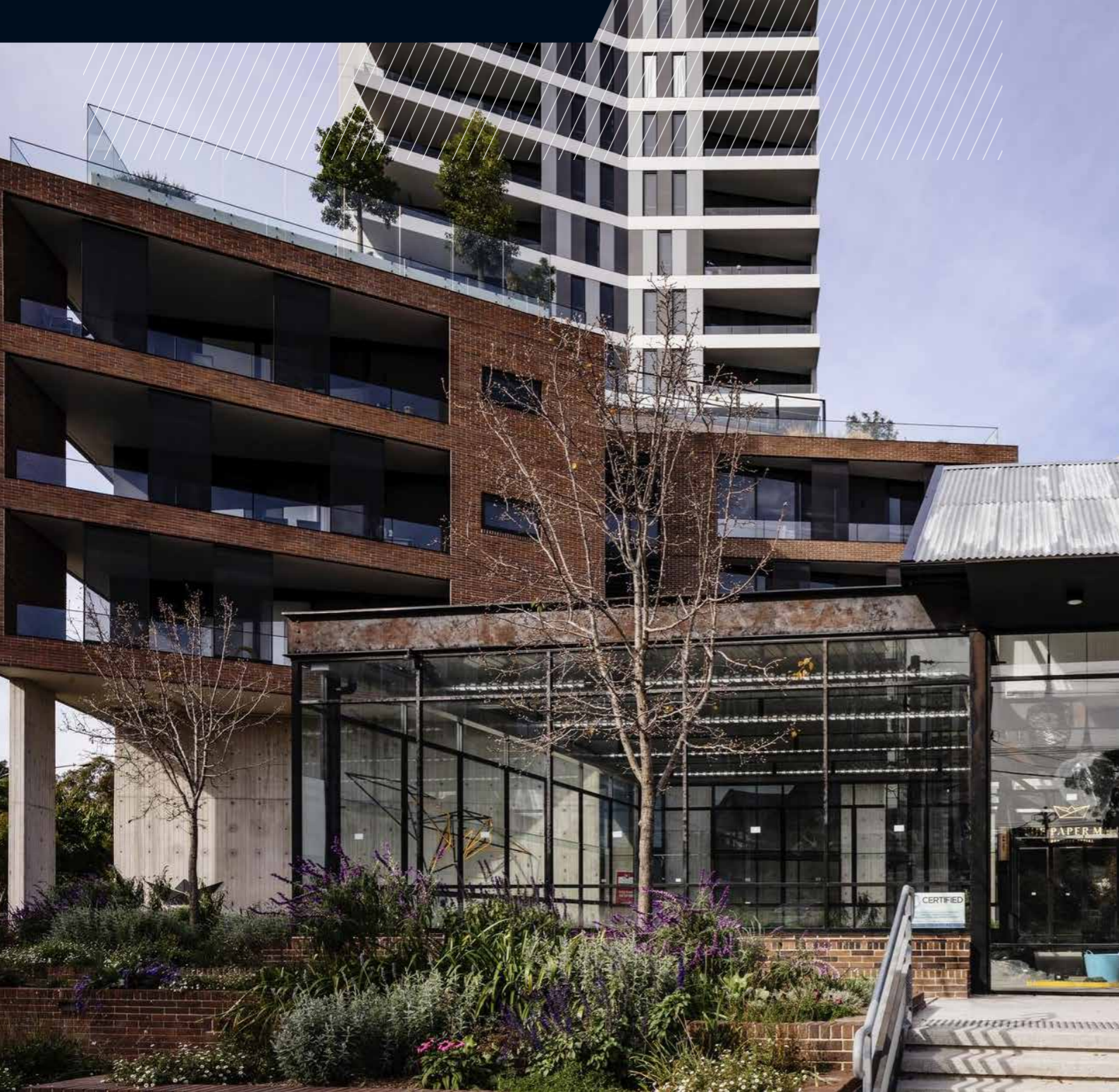

SMARTBRIC ECO-SYSTEM

- Having a universal track and rail options allows a mix and match approach using a system geometry that forms an ecosystem
 - This can provide a highly customisable solution
 - Provides design flexibility and aesthetic fluidity

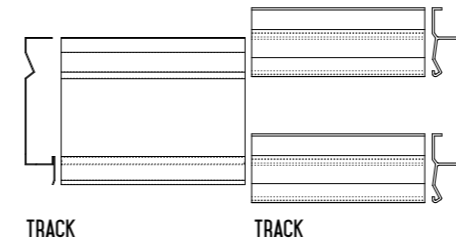

- The ecosystem can accommodate both a fixed Smartbric set-up and a removable (replaceable) Smartbric arrangement whereby:
 - Smartbric Classic System – units are mechanically or physically locked into position by mortar and cannot be removed
 - Smartbric Rapid System - units are removable and can be easily replaced when a standard gauge set-out is adopted

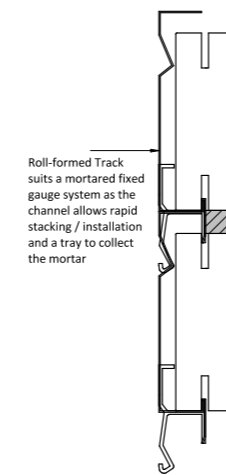

Roll-formed Track suits a mortared fixed gauge system as the channel allows rapid stacking / installation and a tray to collect the mortar

SMARTBRIC CLASSIC - SHOWN WITH TRACK AND RAIL

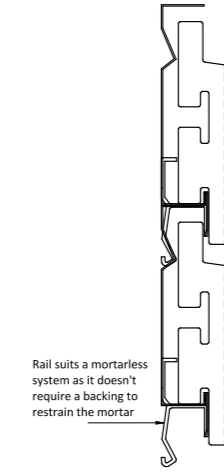

Rail can be slower to install but allows for greater flexibility and can accommodate units of different sizes (variable gauge)

Rail suits a mortarless system as it doesn't require a backing to restrain the mortar

SMARTBRIC RAPID - SHOWN WITH TRACK AND RAIL

- Universal track and rail arrangement provides flexibility to increase utility and function

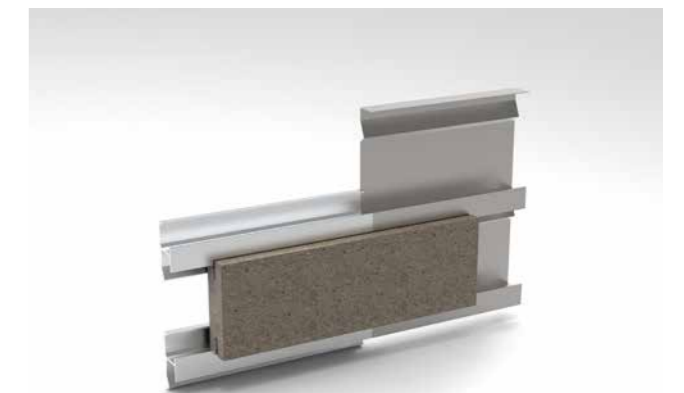
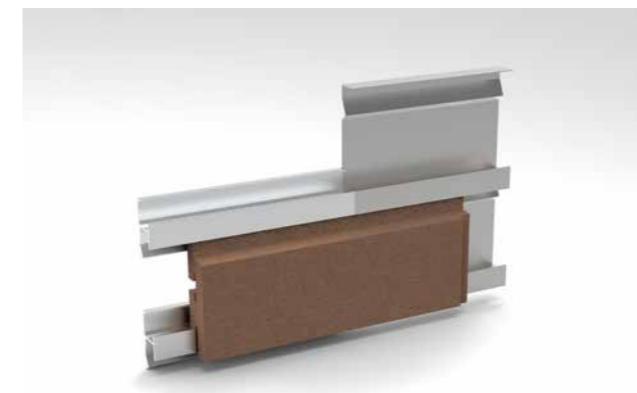

- A suitably profiled extrusion, roll-formed or folded or routed component can be fitted to provide decorative trim options

LOW MAINTENANCE - REQUIRES VIRTUALLY NO MAINTENANCE

Rainscreen cladding systems require almost zero maintenance. In case of a necessary brick facing exchange or replacement, this is easy to do with Smartbric Rapid. The Smartbric facade system does not need special care, maintaining an aesthetic appearance for many decades.

THE POSSIBILITY OF DISMANTLING INDIVIDUAL BRICK FACINGS - SMARTBRIC RAPID

Individual Smartbric Rapid brick facings are easily removed and just as easily installed in place without dismantling other cladding elements. Post installation of services, laying communications, and replacing damaged bricks are no longer a problem.

- Profiled trim can be fitted to provide decorative finishing options
 - Designed to be installed horizontally but can also be installed vertically or at an inclination
- Individual modules can be locked into position by:
 - Mortar (wet system)
 - Mechanical means - using narrow gauge rail spacing, spacers and joiners, or forming and folding tabs on mounting track (dry system)

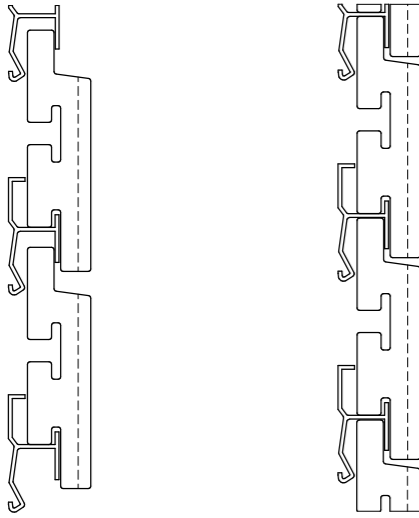

GENERAL STANDARD GAUGE

LOCK-IN TIGHT NARROW GAUGE

- Individual units can also be secured into position in a manner that allow for removal and replacement without compromising performance as a façade system.

ENGINEERING COMPLIANCE AND STRUCTURAL SPECIFICATIONS

Smartbric cladding system has been tested and engineer assessed to comply with:

- NCC Volume One B1D4 and ABCB Housing Provisions 2.2.4 Determination of structural resistance of materials and forms of construction, for actions determined in accordance with NCC Volume One B1D3 and ABCB Housing Provisions 2.2.3.
- NCC Volume One F3P1 and Volume Two H2P2 Weatherproofing.

The design checks are in accordance with the following standards:

- AS/NZS 1170.1
- AS/NZS 1170.2
- AS 1562.1
- AS/NZS 4284
- AS4055

The structural frame supporting the Smartbric cladding system shall be designed and certified by others for the appropriate actions for the site and project parameters.

The following tables are the design tables for the rail and track for stud spacings of 300mm, 450mm, and 600mm. The design basis for the tables is as follows:

- Capacity of the rail and track in bending.
- Capacity of the rail and track in bearing.
- Capacity of the connection of rail/track to the specified S-section batten.
 - 1.2 mm BMT G500 ($f_y = 500$ MPa, $f_u = 520$ MPa).
- Deflection limit of $L/150$ under serviceability wind pressure (taken as $W_s = 0.67 \cdot W_u$).

TRACK AND RAIL SYSTEM - RESIDENTIAL

For residential settings, both rail and track systems have been designed in accordance with AS4055-2012, and are both acceptable for wind for wind classes up to and including N6 and C4, with maximum stud spacing at 600mm centres for general areas and within corner areas.

DESIGN TABLE FOR GENERAL AND CORNER AREAS							
Wind Class	General Areas		Corner Areas		Stud Spacing (mm)		
	Wind Load (kPa)		Wind Load (kPa)		300	450	600
	W_u	W_s	W_u	W_s			
N1	0.62	0.37	-0.94	-0.55	✓	✓	✓
N2	0.86	0.37	-1.30	-0.55	✓	✓	✓
N3	1.35	0.55	-2.03	-0.83	✓	✓	✓
N4	2.01	0.82	-3.01	-1.23	✓	✓	✓
N5	2.96	1.19	-4.44	-1.79	✓	✓	✓
N6	3.99	1.63	-5.99	-2.45	✓	✓	✓
C1	1.8	0.55	-2.70	-0.83	✓	✓	✓
C2	2.68	0.82	-4.02	-1.23	✓	✓	✓
C3	3.94	1.19	-5.91	-1.79	✓	✓	✓
C4	5.33	1.63	-7.99	-2.45	✓	✓	✓

TRACK AND RAIL SYSTEM - COMMERCIAL

TRACK AND RAIL SYSTEM - COMMERCIAL DESIGN TABLE				
Wind Load (kPa)		Stud Spacing (mm)		
W_u	W_s	300	450	600
0.5	0.34	✓	✓	✓
1.0	0.67	✓	✓	✓
1.5	1.01	✓	✓	✓
2.0	1.34	✓	✓	✓
2.5	1.68	✓	✓	✓
3.0	2.01	✓	✓	✓
3.5	2.35	✓	✓	✓
4.0	2.68	✓	✓	✓
4.5	3.02	✓	✓	✓
5.0	3.35	✓	✓	✓
5.5	3.69	✓	✓	✓
6.0	4.02	✓	✓	✓
6.5	4.36	✓	✓	✓
7.0	4.69	✓	✓	✓
7.5	5.03	✓	✓	✓
8.0	5.36	✓	✓	✓

NOTE: S-Section batten, substrate frame and their connections may govern the design specification over the track and rail system specifications in these tables.

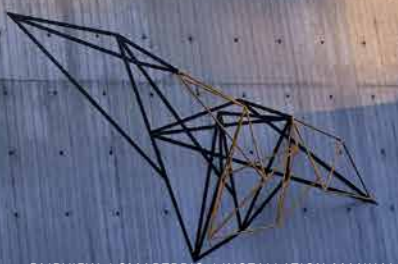
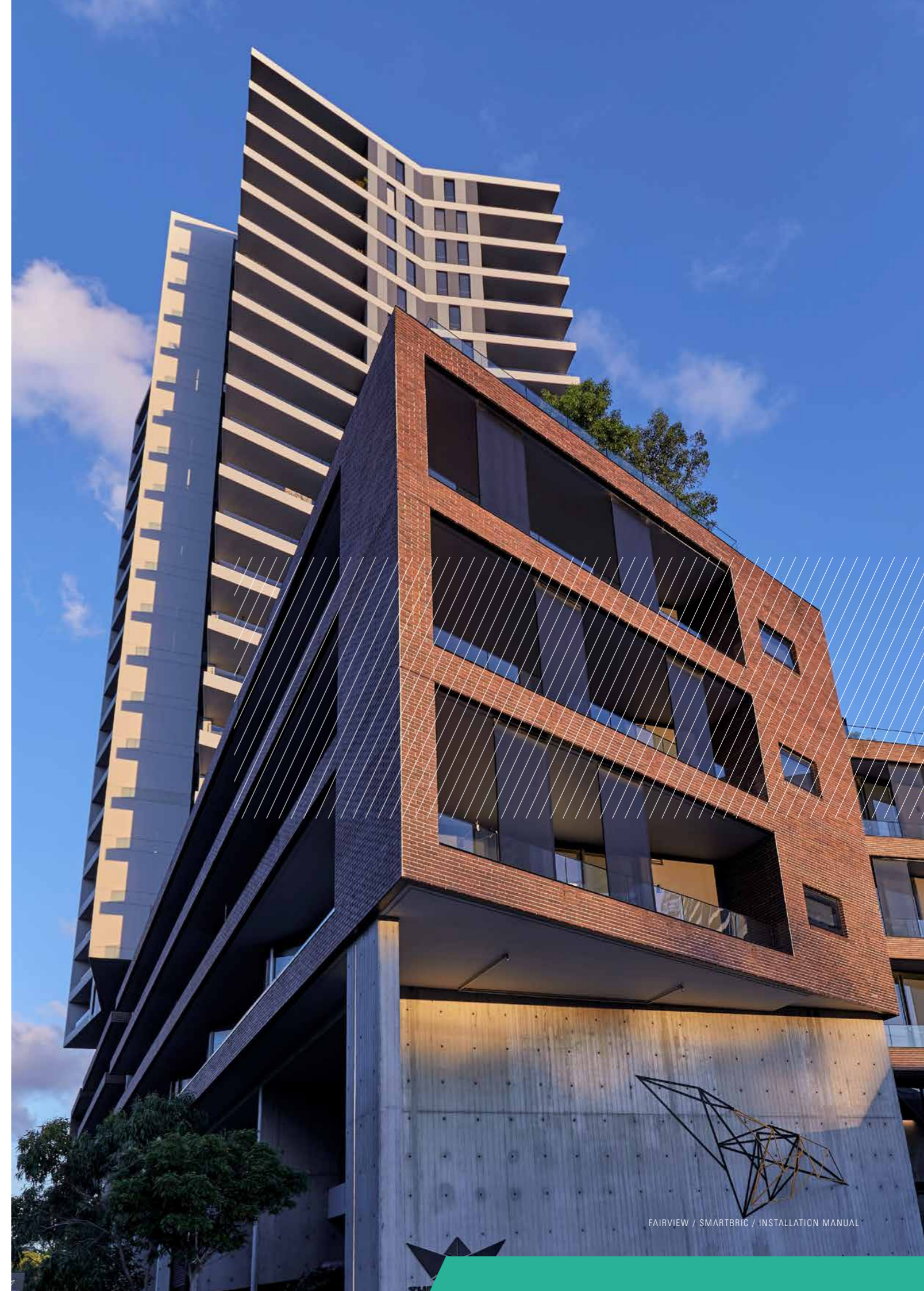

FIRE

The demand for specification and deemed non-combustible façades have fast become the industry norm. As a vitrified clay and concrete masonry unit in combination with metal track and rail mounting system, Smartbric is deemed non-combustible under the provisions of the National Construction Code (NCC).

WEATHERPROOFING

Smartbric rainscreen facade system forms part of an engineered assembly tested to AS/NZS 4284: Testing of Building Facades to $W_s = +1,650\text{Pa} / -2,500\text{Pa}$; $W_u = +4,000\text{Pa} / -6,000\text{Pa}$, and includes proprietary components specifically developed to improve performance and enhance appearance through:

- Moisture management
- Thermal/Heat management
- Movement management

GENERAL ASSEMBLY

Smartbric Classic Brick units or Smartbric Rapid Brick units are designed to be installed onto the Smartbric cold-formed galvanized metal track or Smartbric extruded aluminium rail.

The Smartbric Track is manufactured from Grade G2 Z275 coated steel with a base metal thickness (BMT) of 0.55mm. Alternative coating finishes are also available on request. The Smartbric rail is made from 6060 alloy with T5 temper and 1.5mm wall thickness.

Smartbric Classic brick system requires grouting. The wall assembly can be grouted using a cement-based mortar with Smartbric Add-Mix (plasticizer powder additive) or Smartbric Redi-Mixed polymer modified mortar. Grouting is optional for the Smartbric Rapid brick system.

Wall frame is fitted with a Pro-Clima Solitex Extasana Wall Membrane installed as per manufactures instructions using Pro-Clima Weathertight Sealing Tape and Sill Tape. The details of openings and joints in a facade system have a significant impact on its weatherproofing performance and must be designed and sealed appropriately and suitable for the intended wind loads.

Weatherproofing needs to be installed over the substrate prior to the installation of the Smartbric system in external applications. At internal corners, the air-barrier membrane is to be restrained using a 50mm x 50mm (x 0.55mm minimum) galvanised angle fixed with a suitably coated 10Gx16mm hex head self-drilling metal screw (or equivalent).

Cut edges are to be sealed to protect against moisture penetration into the cavity space. The system requires appropriate attention to drainage including drained horizontal weep screen drain system and appropriate flashings around windows, doors and penetrations to prevent moisture ingress.

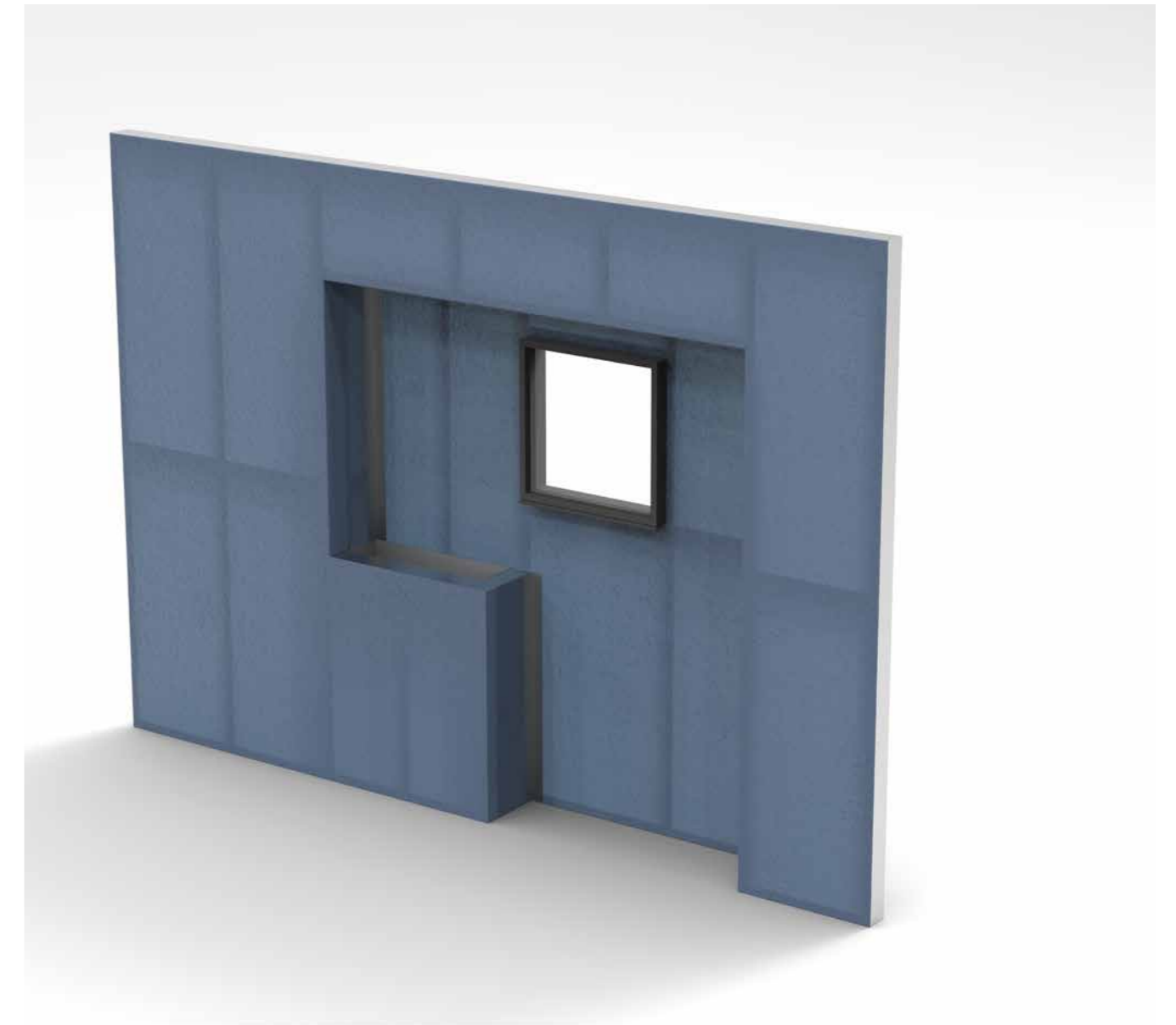

S-Section battens (or alternate top-hat battens) are fixed to sub-structure framework with the appropriate fixings (using 1 x 12G x 20mm hex head self-drilling metal screw at batten crossing for a metal stud frame or to appropriate substrate as per designer's instructions). 35mm S-Section battens are to be installed at 600mm maximum centres.

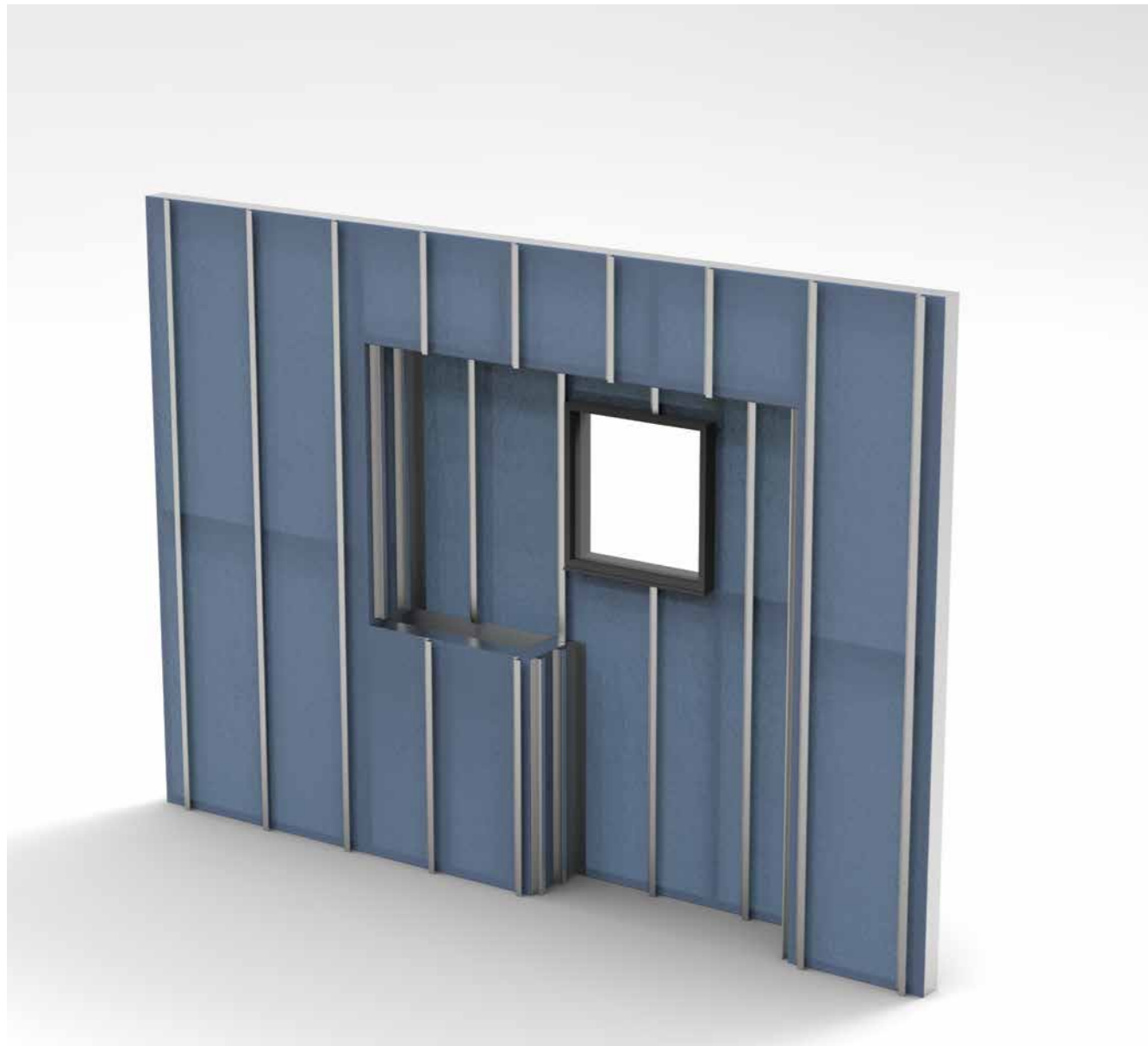

Movement Joints - Vertical and horizontal movement joints should be provided in the Smartbric system to accommodate for adequate thermal expansion and contraction of the materials in the system and possible movement and deflection in the overall structure and substrate that the system to which it is attached. Intersecting tracks and rails should not touch or butt up against each other.

Smartbric Track or Smartbric rail is fixed to 35mm S-Section batten (1.0mm BMT G500) are attached to frame structure using a 10Gx16mm hex head self-drilling metal screw, minimum one per support.

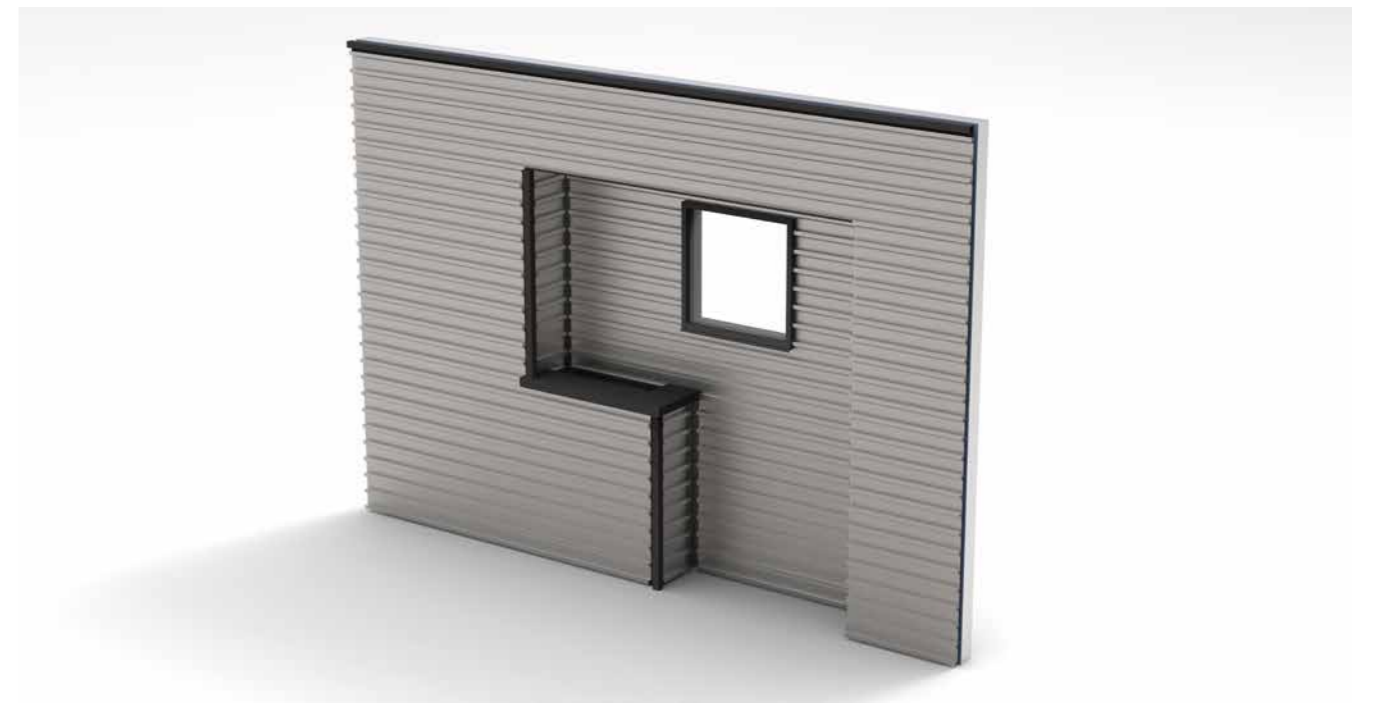
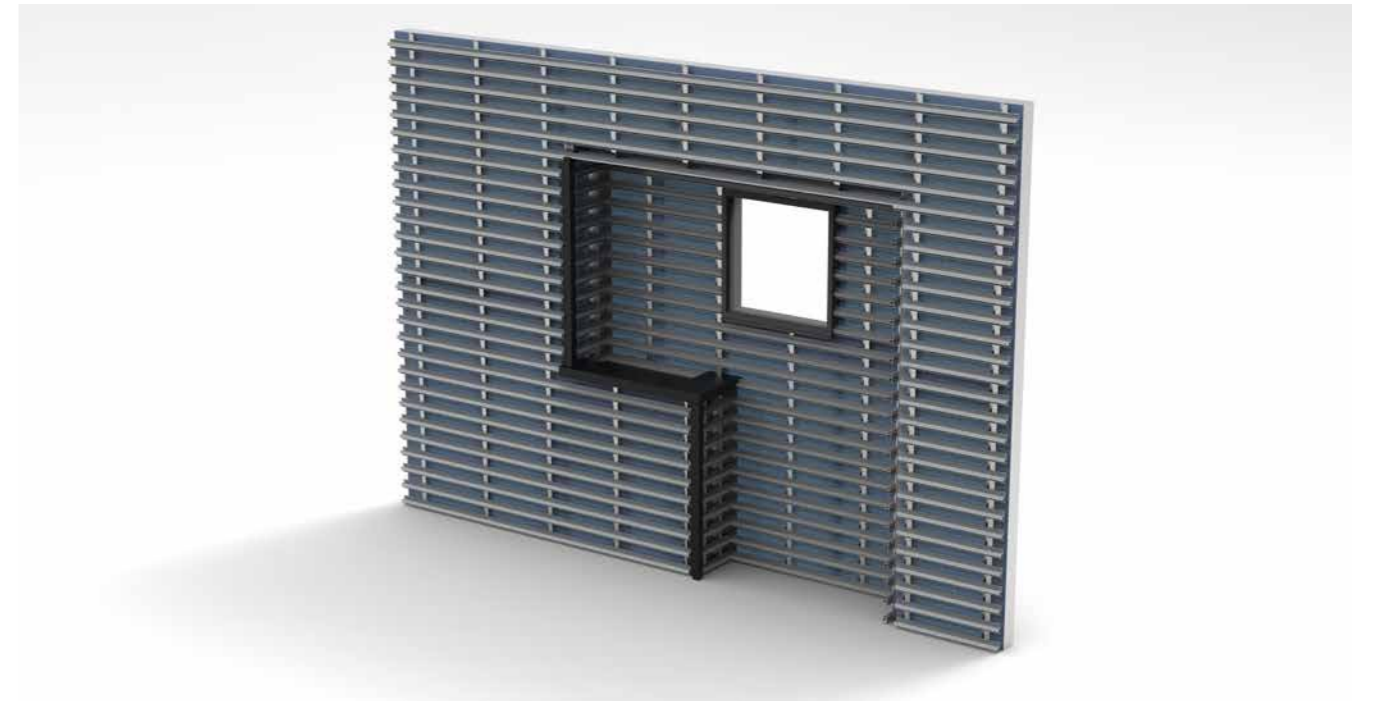

A top-hat style batten may also be used as an alternative to the 35mm S-Section batten. Refer to Fairview Top Hat Spacing Datasheet and Fairview S-Section Batten Spacing Datasheet for further information.

The Smartbric tracks/rails are installed from the bottom working up a wall.

Smartbric rails are generally supplied in 6500mm lengths.

Smartbric tracks are generally supplied in 2400mm lengths.

Tracks and rails are to be butt jointed over the vertical supports using an appropriate fastener and joints between adjacent courses should be staggered.

Note: Do not use cutting tools and methods which may generate high temperatures and swarf that can damage the tracks galvanized coating such as abrasive disc cutters.

Smartbric Classic brick units or Smartbric Rapid brick units are simply inserted and secured into the Smartbric track or Smartbric rail.

When installing the Smartbric Classic, spacers are used to set out the width of the perpendicular joints. When using Smartbric Classic in combination with the Smartbric track, a permanent or temporary (removable) spacer can be used. When installing Smartbric Classic in combination with the Smartbric rail, a permanent spacer is to be used to avoid mortar falling into the cavity void. Once facings are secured in the track or rail, they can be shifted into their final place and mortared (as required).

Smartbric Classic brick system requires grouting with either a cement-based mortar with Smartbric Add-Mix (plasticizer powder additive) or Smartbric Redi-Mixed polymer modified mortar. Grouting is generally not required for the Smartbric Rapid brick system but is optional if desired.

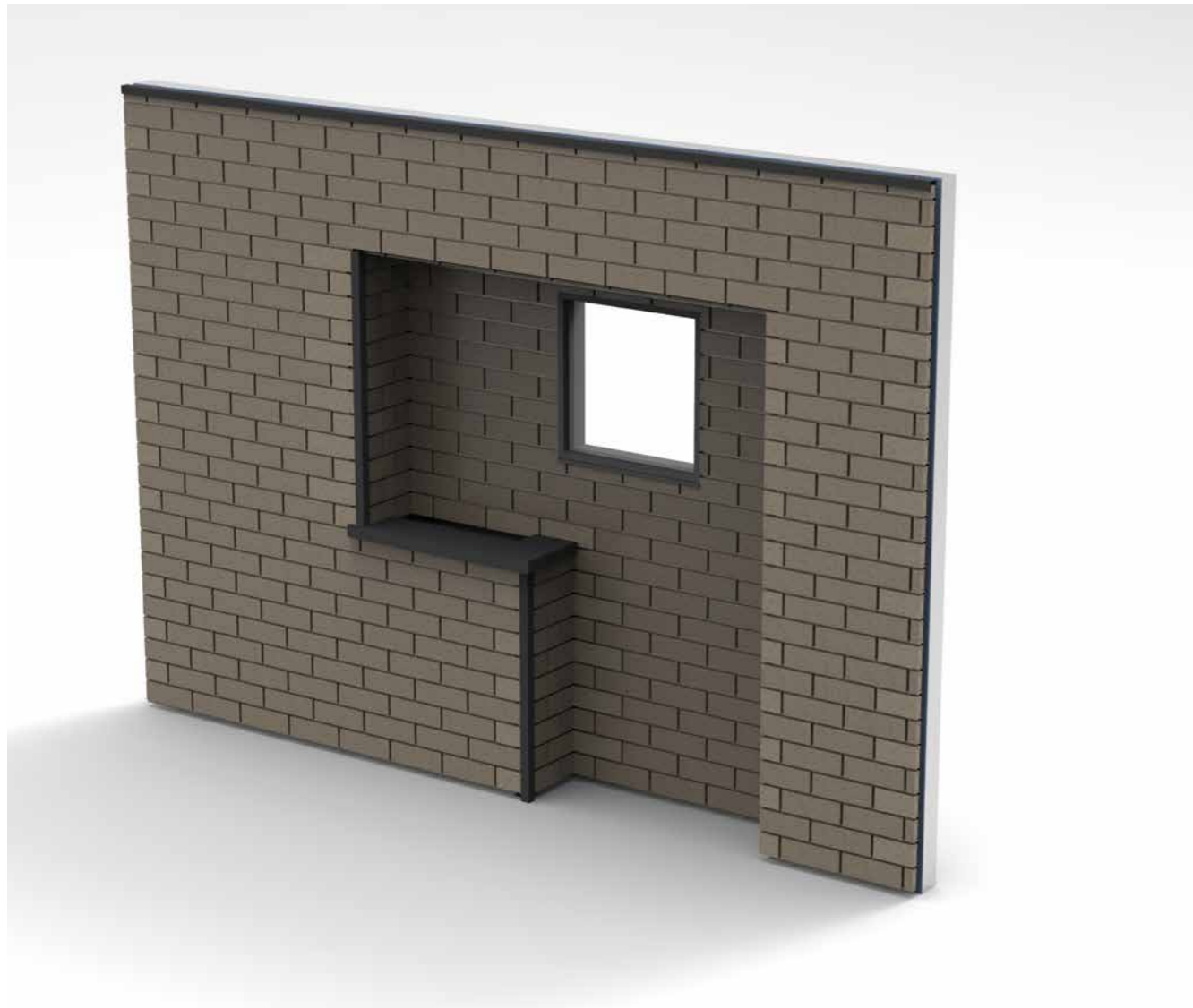

SMARTBRIC RAIL SYSTEM

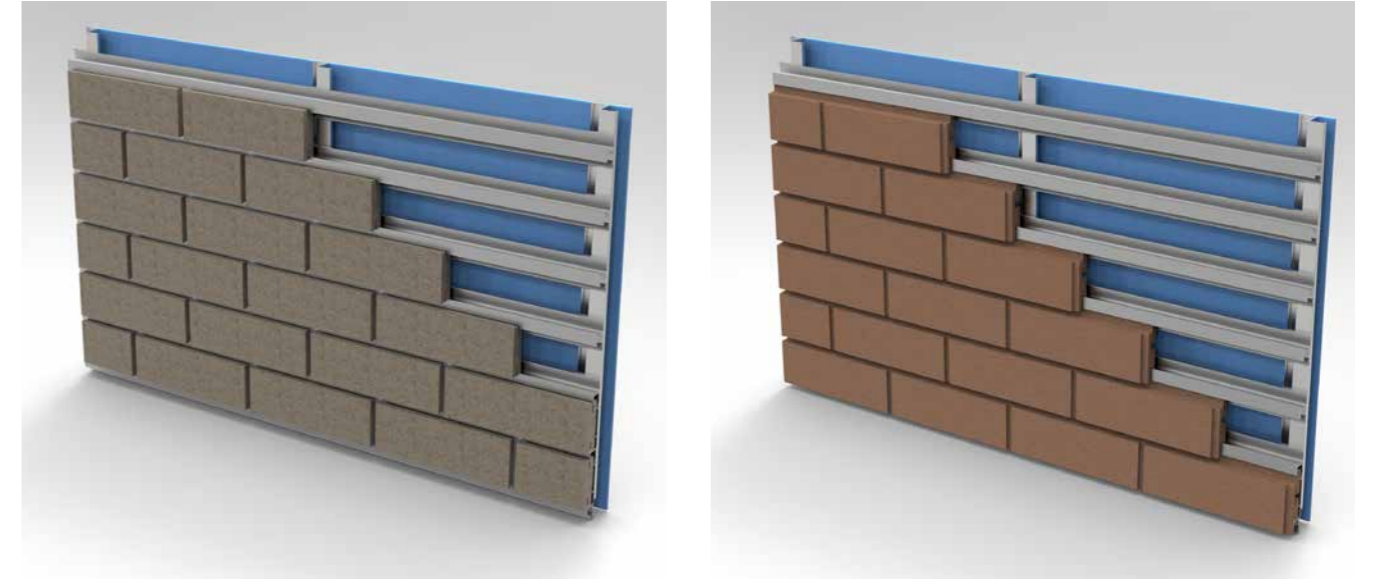

The Smartbric rail system has the distinct advantage of using independent rails to accommodate the Smartbric masonry units. By adopting the standard 86mm rail gauge spacing, this enables the Smartbric units to be inserted (or removed) from a front facing position. Alternatively, by reducing the rail spacing (77mm-85mm), this takes away the flexibility to insert or remove the unit from the front facing position. When adopting a closer rails rail spacing, masonry units can be inserted and fed (by sliding) along rails from an end position. A closer spacing (tighter gauge), traps the Smartbric within the rails making it ideal for applications where security is required such as soffits.

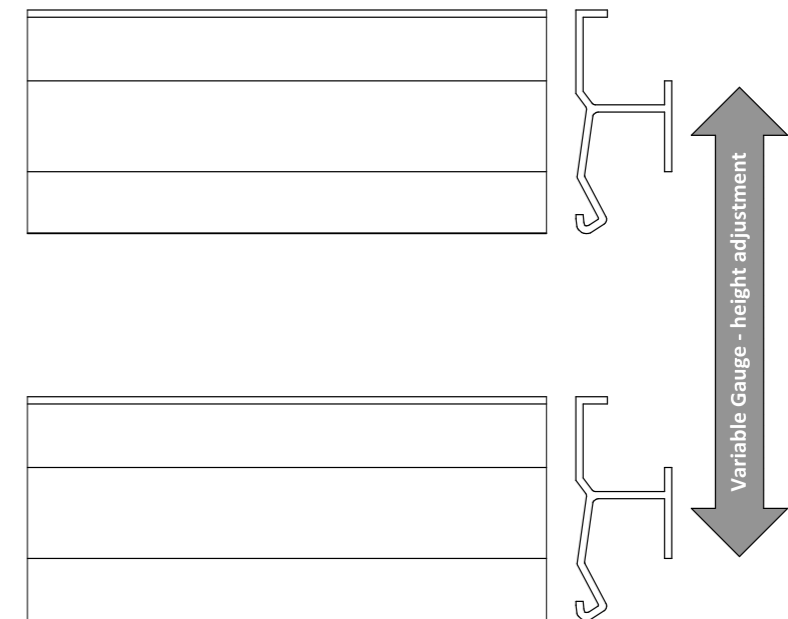

SMARTBRIC CLASSIC – INSTALLATION SEQUENCE



STEP 1. TILT



STEP 2. LIFT



STEP 3. ENGAGE

SMARTBRIC RAPID – INSTALLATION SEQUENCE



STEP 1. TILT



STEP 2. LIFT



STEP 3. ENGAGE

RAIL SYSTEM – ASSEMBLY

The Smartbric rail system is simply screwed onto the battens installed at the appropriate spacings. Prior to fixing rails into position, rail spacing needs to be set (based on size, style and method of insertion of the Smartbric to be used).

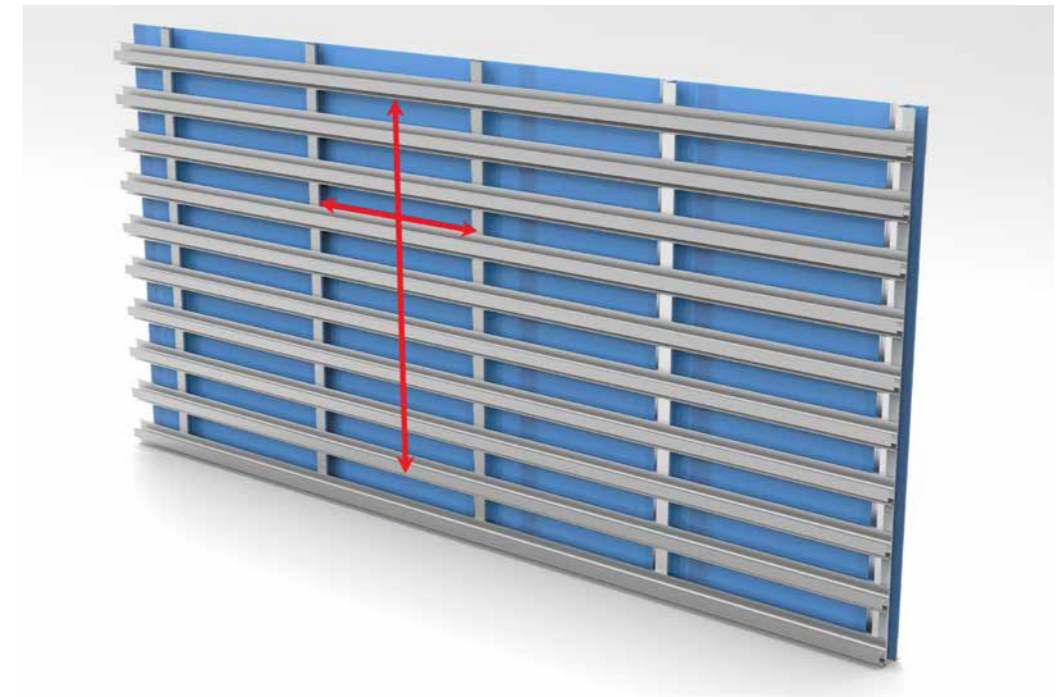
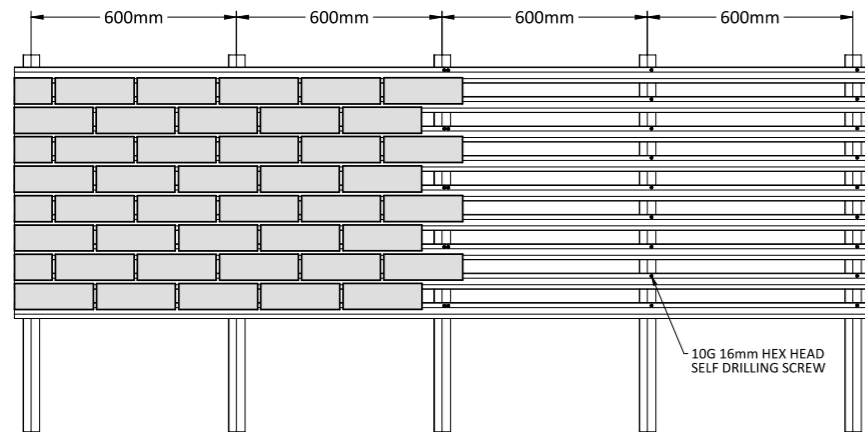

Marking rail fixing locations along the battens can be done by various methods:

- Marking individual locations along the battens with a marker (better suited to small jobs)
- Using a template or spacer to locate individual rails sequentially
- Using a template or spacer to set up successive multiple rails simultaneously

Starting from the bottom of the wall, work upwards from the bottom until reaching the top. Ensure that first row of rail/s is horizontal and set at the desired starting datum height.

SMARTBRIC SPACING BRACKET

To facilitate faster and more accurate installation of the Smartbric rail system, Fairview can supply a Rails Spacer Bracket Rig (or CAD drawings to make your own using a CNC router), onto which rails can be placed at a set spacing prior to screw fixing of the rails onto the battens. After securing rails into position, the Smartbric Rails Spacer Bracket Rig can be easily disengaged by unhooking from the rails whereby it is ready for reloading.



SMARTBRIC TRACK SYSTEM

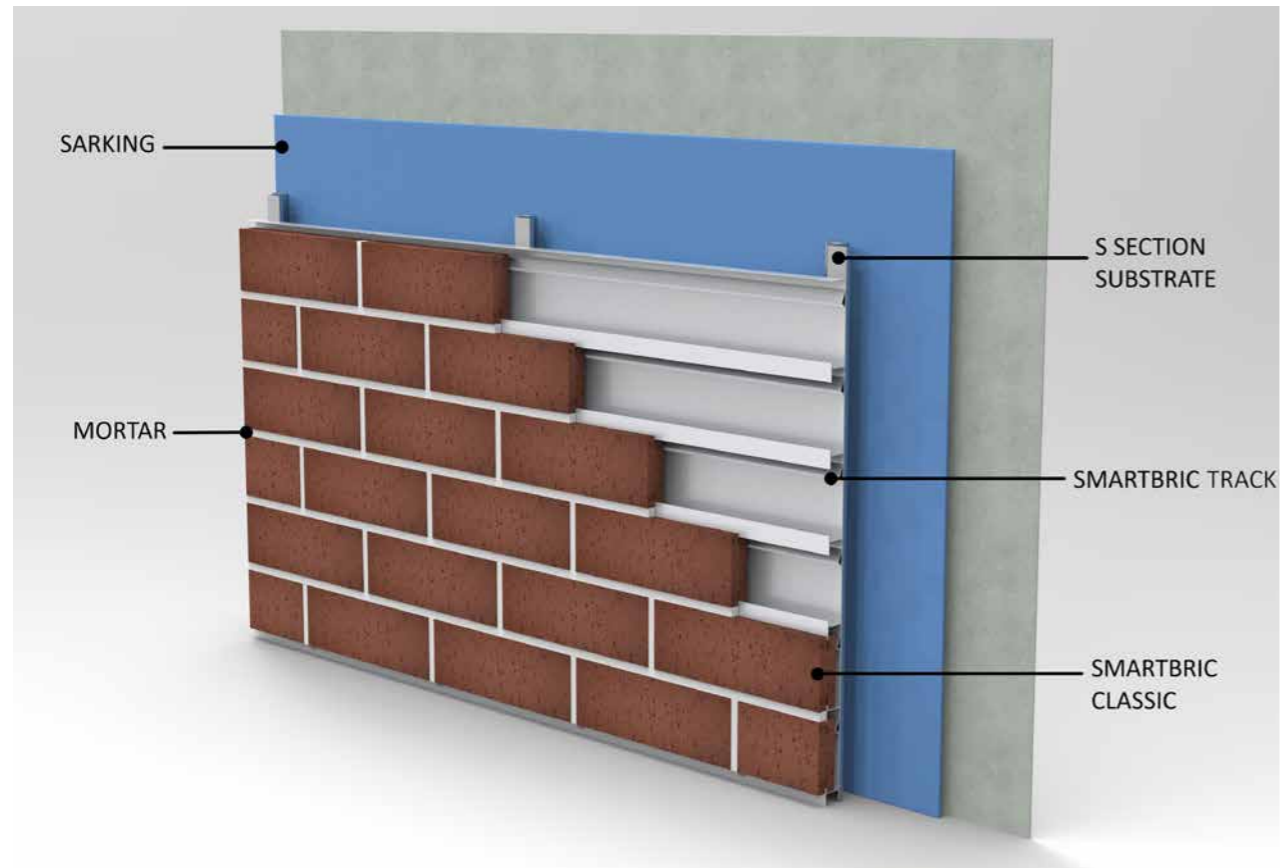

The Smartbric Track system is simply screwed onto the battens installed at the appropriate spacings. The standard Smartbric Track has a set gauge (height) of 86mm and is designed to easily stack and nest into each other.

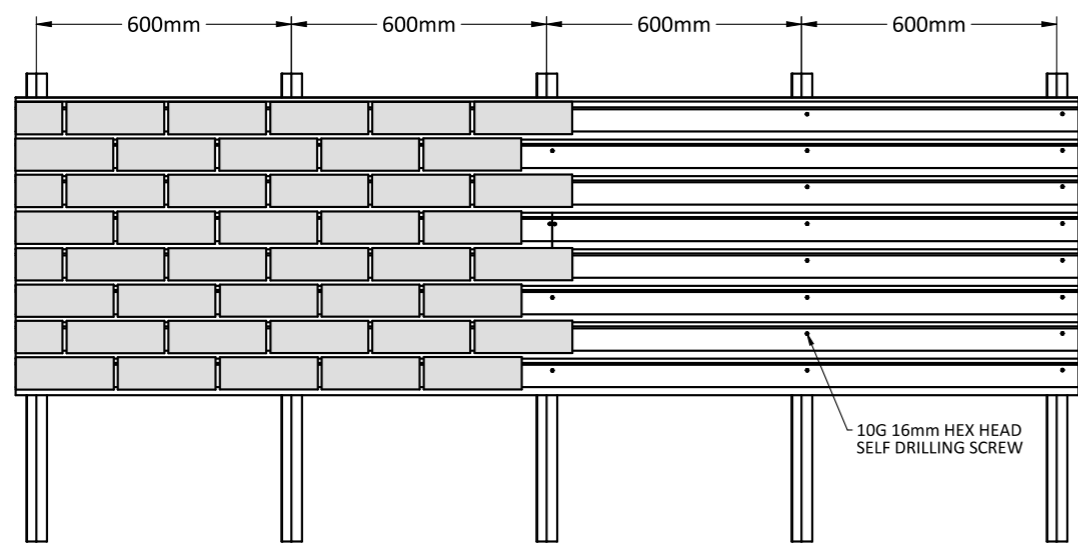

SMARTBRIC CLASSIC - 25MM UNITS



SMARTBRIC CLASSIC - INSTALLATION SEQUENCE (FOR SMARTBRIC RAIL AND SMARTBRIC TRACK)



STEP 1. TILT

STEP 2. LIFT

STEP 3. ENGAGE

Spacers are inserted between Smartbric Classic units to maintain a consistent perpend joint width and to prevent mortar from dropping into the cavity. Note that when using the Smartbric rail system the spacer is necessary as there is no other support backing to retain the mortar.

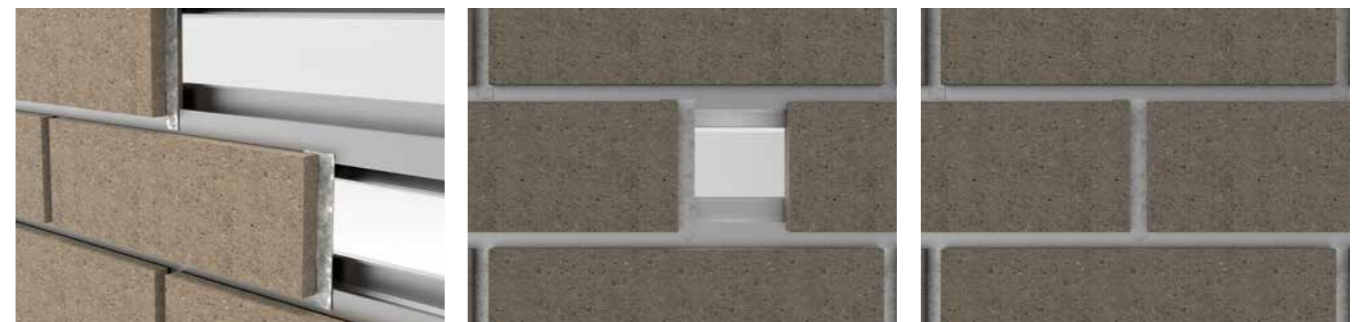

When using the Smartbric Tack System, regularly spaced perpend joint gaps in a grid pattern at 450mm - 600mm centres can be used to inject additional mortar to enhance the overall rigidity of the system. By injecting mortar into the perpend joint cavity, mortar can flow to the rear of the brick providing an under-lock and a wall with improved resistance to impact.

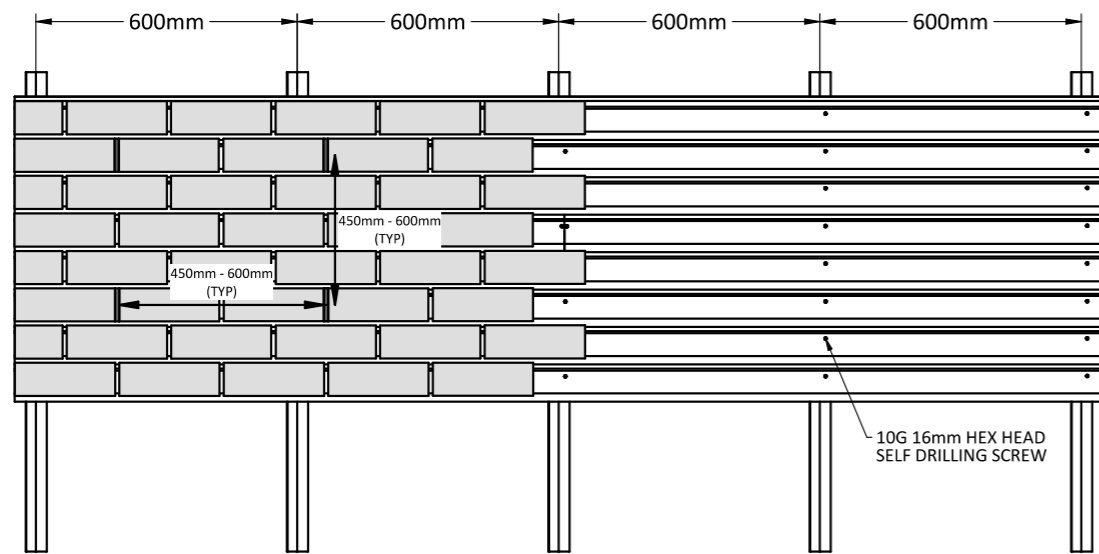

SMARTBRIC RAPID - 25MM FACINGS

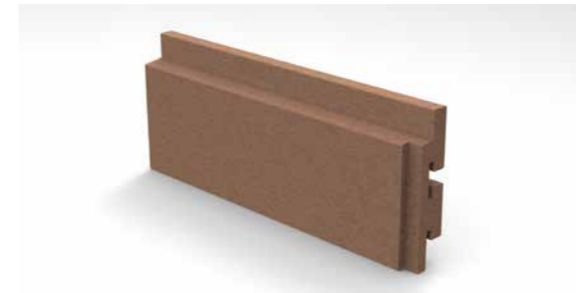

SMARTBRIC RAPID - INSTALLATION SEQUENCE (FOR SMARTBRIC RAIL AND SMARTBRIC TRACK)



STEP 1. TILT

STEP 2. LIFT

STEP 3. ENGAGE

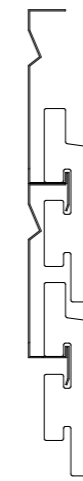

Smartbric Rapid facings incorporate rear slot that can be utilised primarily to accommodate a joiner for general locking together of units and for forming corner units.

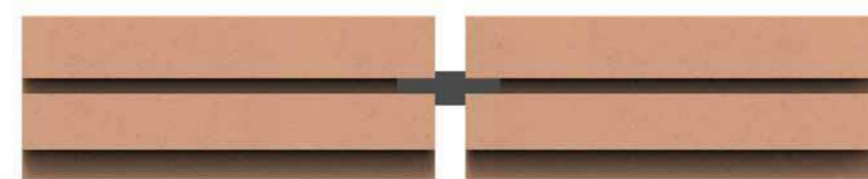

The rear slot can also be used to accommodate the Smartbric Rail or Track and can serve as an alternate attachment point and may be useful when:

- Units are cut (longitudinally) - and an alternative fixing point is required
- Peculiar layouts occur
- Batten / louver look is desired (rail system)

DESIGN & SELECTION

The Smartbric system is a non-load bearing ventilated rain screen façade intended for use in low to medium rise residential-commercial applications and internal fit outs. The Smartbric system includes the brick facings (and corners), rail, track, mortar (including mortars with Add-Mix additive and Pre-Mix mortar), and fixings to the vertical support structure. The vertical supporting structure and substrate is not part of the Smartbric system.

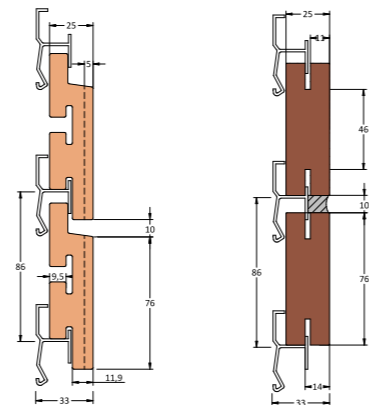
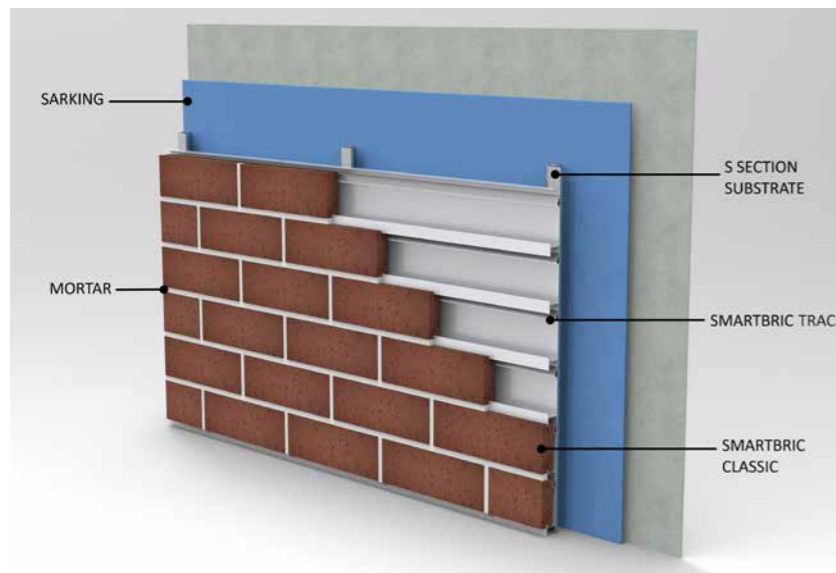
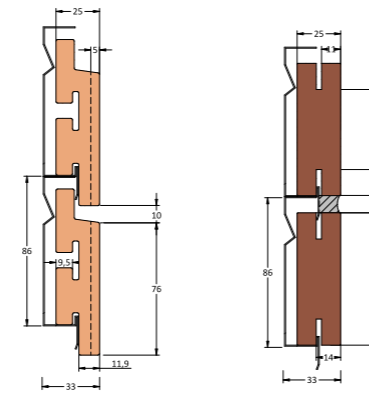
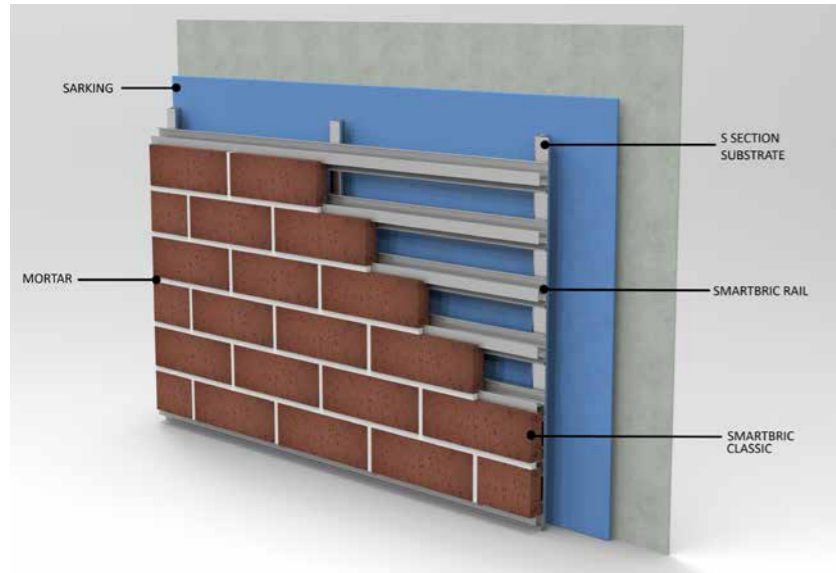

SYSTEM WEIGHT:

Nominal design weight of the Smartbric system is 55kg/m². Note: The weight of the Smartbric system may vary depending on materials and the shape and profile of the brick used.

COMMERCIAL BUILDINGS (CLASS 2 – 9)

Both Smartbric rail and Smartbric track systems have been designed and are acceptable up to and including a maximum ultimate wind load of 8.0 kPa, with vertical supports and fixings spaced at maximum span of 600 mm.

TRACK AND RAIL SYSTEM - COMMERCIAL DESIGN TABLE				
Wind Load (kPa)		Stud Spacing (mm)		
W _u	W _s	300	450	600
0.5	0.34	•	•	•
1.0	0.67	•	•	•
1.5	1.01	•	•	•
2.0	1.34	•	•	•
2.5	1.68	•	•	•
3.0	2.01	•	•	•
3.5	2.35	•	•	•
4.0	2.68	•	•	•
4.5	3.02	•	•	•
5.0	3.35	•	•	•
5.5	3.69	•	•	•
6.0	4.02	•	•	•
6.5	4.36	•	•	•
7.0	4.69	•	•	•
7.5	5.03	•	•	•
8.0	5.36	•	•	•

WEATHERPROOFING PERFORMANCE

The Smartbric System has been tested in accordance with AS/NZS4284 and assessed as meeting the performance requirements of NCC Volume One F3P1 and Volume Two H2F2 for weatherproofing.

AS/NZS 4284:2008 Testing of building facades involves the testing of a full-scale wall incorporating construction features including:

- Wall junctions
- Vertical and horizontal control joints
- Parapet flashings and balcony drainage
- Footer hand header installation arrangements
- Soffits
- Internal and external corner junctions
- Footer starter and header termination configurations
- Wall penetrations (windows and doors)
- Air/water/vapour barrier detailing

WEEP HOLES

To allow drainage of moisture from the cavity, horizontal weep holes (weep hole screens or similar) are required at 1200mm centres at the panels base and at the floor-slab edges (and other horizontal planes such as window sills) to ventilate the cavity space and via the flashing.

MATERIAL PROPERTIES

For the Smartbric systems, allow 48 pieces per square metre (m²) when using 230mm long x 76mm high Classic brick or 240mm long x 76mm high Rapid bricks. Product is supplied at 50 units per m².

BRICK FACINGS

All dimensions on clay and concrete brick products will vary according to the type of raw materials & firing and manufacturing techniques.

SMARTBRIC RAPID – EXTRUDED CLAY

SMARTBRIC RAPID – EXTRUDED CLAY PRODUCT SPECIFICATION – TYPICAL PROPERTIES		
	Material	Natural Clay
	Size (L x H x W)	230 (+10)mm x 76mm x 25mm
	Weight	0.85 kg each
	Thickness	± 2%
	Length	± 5%
	Dimensional Stability	± 2%
	Frost Resistance	Not less than 150 cycles
	Water Absorption	< 10% (typically ~ 4%)
	Corner	Mitred only
	Combustibility	Clay masonry units are non-combustible
AS4456.11 – Breaking Load Testing of Units		
Breaking Load Mean	1.8kN	
Breaking Load Std Dev	0.1kN	
Breaking Load Characteristic Strength	1.1kN	
Modulus of Rupture Mean	9.8MPa	
Modulus of Rupture Std Dev	0.6Mpa	
Modulus of Rupture Characteristic Strength	6.3MPa	
Surface Indentation Test on Aluminium Rail - NCC 2022 Specification S6C10(d) and S6C11(e)	Pass	
Surface Indentation Test on Gal. Steel Track - NCC 2022 Specification S6C10(d) and S6C11(e)	Pass	
Durability Class AS/NZS 4456.10 Method: B - Resistance to Salt Attack – Sodium Sulphate	Resistance to Salt Attack. Met criterion (b) Exposure Grade or General Purpose or as required by the site's corrosivity category	
Total Mass Loss - All Cycles -Chloride	0.1g (mean)	
Total Mass Loss - All Cycles -Sulphate	0.1g (mean)	

SMARTBRIC CLASSIC – EXTRUDED CLAY

SMARTBRIC CLASSIC – EXTRUDED CLAY PRODUCT SPECIFICATION – TYPICAL PROPERTIES		
	Material	Natural Clay (Properties typical of brown / white clay)
	Size (L x H x W)	230mm x 76mm x 25mm
	Weight	0.85 kg each
	Dimensional Tolerance	± 2mm
	Convexity and Concavity	± 1mm
	Heat Transfer Coefficient	1.1
	Water Absorption	~ 5%
	Corner	Mitred only
	Combustibility	Clay masonry units are non-combustible
	Specials	Facings Extruded 15mm – 55mm depending on brick type
AS4456.11 – Breaking Load Testing of Units		
Breaking Load Mean	1.1kN	
Breaking Load Std Dev	0.3kN	
Breaking Load Characteristic Strength	0.5kN	
Modulus of Rupture Mean	8.8MPa	
Modulus of Rupture Std Dev	2.1MPa	
Modulus of Rupture Characteristic Strength	3.2MPa	
Surface Indentation Test on Aluminium Rail - NCC 2022 Specification S6C10(d) and S6C11(e)	Pass	
Surface Indentation Test on Gal. Steel Track - NCC 2022 Specification S6C10(d) and S6C11(e)	Pass	
Durability Class AS/NZS 4456.10 Method: B - Resistance to Salt Attack – Sodium Sulphate	Resistance to Salt Attack. Met criterion (b) Exposure Grade or General Purpose or as required by the site's corrosivity category	
Total Mass Loss - All Cycles -Chloride	0.1g (mean)	
Total Mass Loss - All Cycles -Sulphate	0.1g (mean)	

SMARTBRIC CLASSIC – DRY PRESSED CLAY

The information below is for general description purposes only and based on the specifications of the original full brick manufactured to AS/NZS 4455.1.

The dimensions noted below are a nominal or indicative size only. Australian bricks are manufactured to an Australian Standard DW2 and bricks of 1st quality rating are deemed to comply with this standard and are tested accordingly.

Variation on length is +/- 50mm (measured over 20 Bricks)

Variation on height is +/- 40mm (measured over 20 Bricks)

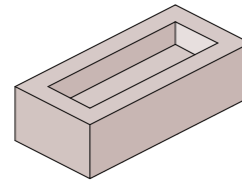

SMARTBRIC CLASSIC – DRY PRESSED CLAY PRODUCT SPECIFICATION – TYPICAL PROPERTIES			
	Material	Natural Clay	
	Dimensions AS/NZS 4456.3 (L x H x W)	228mm x 76mm x 25mm	
	Weight - Facings	0.85 -1.0 kg per unit (depending on brick) 40.8 - 48 kg /m ² (based on 48 units/m ²)	
	Weight - Corners	1.15 kg per unit (average based on 3.6kg brick)	
	Dimensional Tolerance (Thickness)	± 3mm	
	Coefficient of expansion AS/NZS 4456.11	Less than 0.008mm/m/°C, providing a maximum service life ambient air temperature of 40°C	
	Water Absorption AS/NZS 4456.14	< 10%	
	Initial Rate of Absorption AS/NZS 4456.17	< 1.0 kg/m ² /min (mean around 0.4 kg/m ² /min)	
	Breaking Load AS/NZS 4456.5	>1.0Mpa (typical)	
	Corner	Cut corners available. Can be mitred	
	Combustibility	Clay masonry units are non-combustible	
	Specials		
	Facings	Facings cut 15mm – 55mm depending on brick type	
	Corners	110mm x 25mm return – return grooved 110mm x 11mm return – with no groove	
	Potential to Effloresce AS4456.6	Nil	
Pitting due to Lime Particles AS4456.13	Nil		
Surface Indentation Test on Aluminium Rail - NCC 2022 Specification S6C10(d) and S6C11(e)	Pass		
Surface Indentation Test on Gal. Steel Track - NCC 2022 Specification S6C10(d) and S6C11(e)	Pass		
Durability Class AS/NZS 4456.10 Method: B - Resistance to Salt Attack – Sodium Sulphate	Resistance to Salt Attack. Met criterion (b) Exposure Grade or General Purpose or as required by the site's corrosivity category		
Total Mass Loss - All Cycles -Chloride	0.1g (mean)		
Total Mass Loss - All Cycles -Sulphate	0.1g (mean)		

SMARTBRIC CLASSIC - CONCRETE MASONRY (ORIGINAL BRICK)

The information above is for general description purposes only and based on the specifications of the original full brick Manufactured to AS/NZS 4455.1 & 4455.3:2008

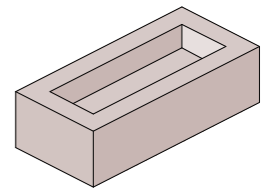

COLOUR:	Storm, Peppercorn, Hazelnut, Limestone, Salt, Moody Grey
FINISH	Smooth
DIMENSIONS:	76 x 110 x 230 mm (H x W x L) Category DW4 as per AS 4455.1, determined in accordance with AS/NZS 4456.3.
STRENGTH:	Characteristic Compressive Strength > 10 MPa
DURABILITY:	Exposure Grade (determined by AS/NZS 4456.10 - Resistance to Salt Attack)
WEIGHT:	3.8 Kg ±10%
NO.	Per pallet: 500 Units
NO.	Per m ² : 50 Units

Refer to Smartbric Technical Data Sheet for further information.

SMARTBRIC TRACK

The standard Smartbric track is roll formed manufactured form Grade G2 galvanised steel with a base metal thickness (BMT) of 0.55mm, and a total coated thickness (TCT) of 0.59mm compliant with AS1397: Continuous hot-dipped metallic coated steel sheet and strip

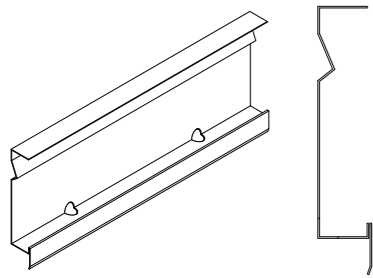

Smartbric track is supplied in 2400mm lengths and can be provided in other lengths on request.

Galvanized steel track has a Z275 coating, meaning 275 grams of zinc per square metre summed over both faces of the steel strip. This corresponds to approximately 0.02 mm overall thickness of zinc per face. Other coating thicknesses, coating systems and stainless steel are available on request for special applications.

IMPORTANT NOTE:

- Coating systems containing aluminium such as Zincolume™, and which are not pre-painted in accordance with AS2728 are not suitable for use with mortar due to adverse reactions with wet cementitious material.
- Steel is considered to be non-combustible under NCC 2022 Volume One C2D10 respectively provided that any applied coatings used are less than 1mm thick.

The Smartbric track is designed for laying Smartbric facing at standard coursing at a set height of 86mm and supports 25mm brick facings up to 55mm (in Smartbric Classic). The Smartbric track suits both Smartbric Classic and 25mm Smartbric Rapid with the traditional brick facing size of 230mm x 76mm. Brick facings engage with track via a tongue and groove locking mechanism. Track is designed to stack and sit neatly on the track below.

Where Smartbric facings need to match existing brickwork using the traditional 7 courses per 600mm rise, a “creeper” track can be supplied to provide a variable gauge set-out. Coursing charts are provided in the General Layout and Cutting section of this guide for reference purposes.

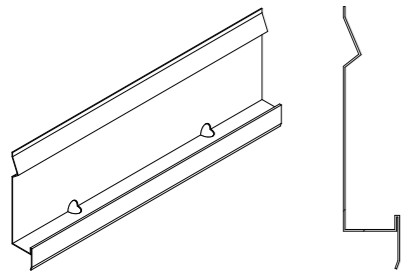

Standard Course Track – fixed gauge standard coursing

- 2400mm x 86mm
- 0.46kg per lineal metre

Creeper Track – variable gauge coursing

- 2400mm x 76mm

Smartbric 25mm Facings and Galvanised Steel Track – average weight / m²

- 55 kg /m² (Approximately)

SMARTBRIC RAIL

The Smartbric rail is manufactured from aluminium extruded from 6060 alloy with T5 temper and 1.5mm wall thickness. The Smartbric rail is recommended where greater durability and corrosive resistance is required.

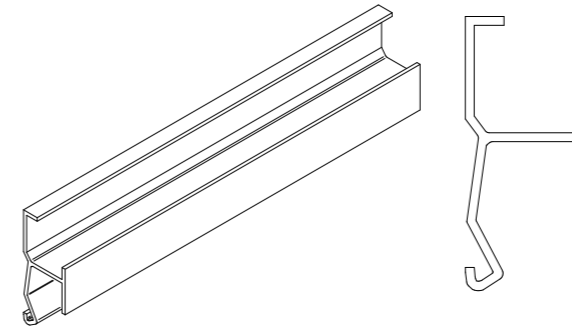

The Smartbric rail suits both Smartbric Classic and 25mm Smartbric Rapid with the traditional brick facing size of 230mm x 76mm. Brick facings engage with rail via a tongue and groove locking mechanism.

SMARTBRIC SYSTEM

Smartbric Cut Facings

- 230 x 76 x 15 ± 3mm
- 0.9kg each (approx.)
- 43.2kg /m² (approx.)

Smartbric Corners

- 110mm return
- 1.15kg (average)

Smartbric Standard Course Track – fixed gauge standard coursing

- 2400mm x 86mm
- 0.5kg per lineal metre
- 5.85kg /m²

Smartbric Creeper Track – variable gauge coursing

- 2400mm x 76mm

Smartbric Rail - Extruded

- Aluminium 6060 - T5

Smartbric 25mm Facings and Galvanised Steel Track – average weight / m²

- 55 kg /m² (Approximately)

DURABILITY

AS4312:2019 provides guidelines for the classification of atmospheric corrosivity zones in Australia and their effect on corrosion of steel and other materials. It defines six atmospheric corrosivity categories ranging from C1 (very low) to C6 (extreme) and as to how to determine the Corrosion Category of a site generally with reference to the distance from a shoreline.

Material AS 4312 Category	Corrosivity	Steel Corrosion Rate ($\mu\text{m}/\text{y}$)	Typical Environment
C1	Very low	<1.3	Dry Indoors
C2	Low (most areas of Australia at least 50km from the coast or at least 1km from sheltered bays would be in this category)	1.3-25	Arid / Urban Inland
C3	Medium (from 1km to 10-50km from breaking surf – much of metropolitan Wollongong, Sydney, Newcastle and Gold Coast are in this category)	25-50	Coastal or Industrial
C4	High (primarily coastal areas - from several hundred metres to about 1km inland from breaking surf or from the shoreline to around 50m for sheltered bays)	50-80	Sea Shore (calm)
C5	Very High (industrial or marine) – common offshore and on the beachfront in regions of rough seas and surf beaches – can extend inland for several hundred metres (in some areas of Newcastle extends around 500m)	80-200	Sea Shore (surf)
CX	Extreme	200-700	Shoreline (severe surf)

For the Sydney region, the most common environmental conditions to be encountered will be category C3, unless the site is within 1 km of a shoreline with surf or rough sea or 50m from a sheltered bay.

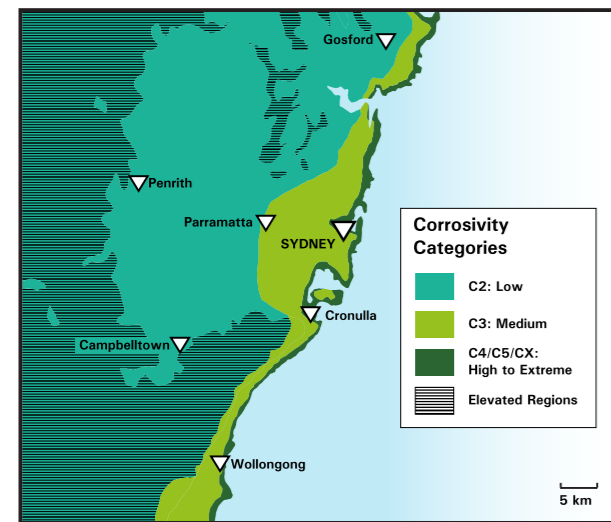

AS 4312:2019 estimated ISO corrosivity categories for Sydney

Given that track/rail and substructure framing is concealed behind the masonry façade, it cannot be readily inspected or replaced without causing significant disruption to the occupants, therefore appropriate judgment needs to be applied in track/rail material selection.

Coating Designation	Coating mass on one face	Coating thickness one face (μm)	Design Life Climate Zone C2 (years)	Design Life Climate Zone C3 (years)	Design Life Climate Zone C4 (years)
Z275	137	19.2	27 +	9 to 27	4.5 to 9
Z600*	300	42	Up to 80		

Reference: Project Remediate – Cladding Replacement Pattern Handbook

* Available on request. Lead time and minimum order quantity apply.

Smartbric material requirement for a 10 - 20 year service life.

AS 4312 Category	Cold Formed Steel Track Coatings as per AS 1397	Extruded Aluminium Rail	Screw Corrosion Resistance Class as per AS 3566.2	Mortar Class as per AS 3700
C1	Z275 - SS Grade 304, 316	6060 - T5 Aluminium	Class 1 Class 2 Class 3 SS Grade 304, 316	M2, M3, M4
C2	Z275 - SS Grade 304, 316	6060 - T5 Aluminium	Class 1 Class 2 Class 3 SS Grade 304, 316	M2, M3, M4
C3	Z275 - SS Grade 304, 316	6060 - T5 Aluminium	Class 3 SS Grade 304, 316	M3, M4
C4	SS Grade 304, 316	6060 - T5 Aluminium	Class 4 SS Grade 304, 316	M3, M4
C5	SS Grade 304, 316	6060 - T5 Aluminium	SS Grade 304, 316	M4
CX	By testing/experience – Contact Fairview			

Note: Alternate track material such as Magnaflow™, Z600 Galvanisaeed and Stainless-steel options are available on request. Lead time and minimum order quantity apply.







As a rainscreen façade, the Smartbric system allows for air/vapour movement and moisture drainage and is less prone to the detrimental effects associated with a closed cavity system. Since the primary fixing system used to attach the track or rail to the building structure uses a batten (or top-hat) system there is no direct contact with mortar as with conventional brick-ties.

PRODUCT COMPATABILITY MATRIX

Additional consideration also needs to be given to compatibility between track/rail and various mortar types. Coating systems containing aluminium such as Zincalume™, and which are not pre-painted in accordance with AS2728 are not suitable for use with mortar due to adverse reactions with wet cementitious material.

Mortars containing lime including pre-mixed pre-packaged products are to be restricted and used with caution. Lime will form an alkaline solution, and a sufficiently alkaline solution will etch an aluminium surface. Hydrated lime solutions are corrosive to galvanized steel and aluminium.

Ensure there's enough ventilation to prevent moisture build-up. The outer layer of aluminium oxide which protects aluminium from attack is stable within a pH range of between about 4 and 8.5. Bricks, concrete and mortar (even after it's cured) can generate highly alkaline waters with a pH of anywhere between 10 and 13 though. If waters like this with corrosively high pH level enter a crevice where there's an unprotected aluminium surface, the natural aluminium oxide layer becomes corroded.

COMBINATIONS	INTERNAL USE		EXTERNAL USE				
	Track	Rail	Track			Rail	
	G2 Z275 (General Purpose)	Mill Finish	G2 Z275 (C2-General Purpose)	G2 350 / Z450 (C2-C3)	Magnaflow (C2-C3)	Aluminium Mill Finish (Coastal)	Aluminium Powder Coated (Coastal)
  SMARTBRIC REDI-MIX	<input checked="" type="checkbox"/>	<input checked="" type="checkbox"/>	<input checked="" type="checkbox"/>	<input checked="" type="checkbox"/>	<input checked="" type="checkbox"/>	<input checked="" type="checkbox"/>	<input checked="" type="checkbox"/>
  SAND-CEMENT MORTAR MIX + SMARTBRICK ADD-MIX	<input checked="" type="checkbox"/>	<input checked="" type="checkbox"/>	<input checked="" type="checkbox"/>	<input checked="" type="checkbox"/>	<input checked="" type="checkbox"/>	<input checked="" type="checkbox"/>	<input checked="" type="checkbox"/>
 MORTAR-LESS	<input checked="" type="checkbox"/>	<input checked="" type="checkbox"/>	<input checked="" type="checkbox"/>	<input checked="" type="checkbox"/>	<input checked="" type="checkbox"/>	<input checked="" type="checkbox"/>	<input checked="" type="checkbox"/>
 SMARTBRIC REDI-MIX	OPTIONAL	OPTIONAL	OPTIONAL	OPTIONAL	OPTIONAL	OPTIONAL	OPTIONAL
 SAND-CEMENT MORTAR MIX + SMARTBRICK ADD-MIX	OPTIONAL	OPTIONAL	OPTIONAL	OPTIONAL	OPTIONAL	OPTIONAL	OPTIONAL

Note: Mortars containing lime not recommended

FASTENERS

All fastening screws must conform to AS3566 - Class 3*. Smartbric Track and Smartbric Rail is to be fixed with the required number of fasteners per sheet at each batten/purlin to meet the required performance values.

For the screw to be properly tightened into metal there should be a minimum of three (3) threads protruding past the support being fixed in to.

Track and rail are to be fixed to 35mm S-Section batten (1.0mm thick), using a 10Gx16mm hex head self-drilling metal screw, one per support. S-Section battens are to be fixed to metal stud frame using 1 x 12G x 20mm hex head self-drilling metal screw at batten crossing.

*NB Class 4 needed in coastal areas.

SUPPORT

FASTENER TYPE



Track and Rail fixing screw to steel 35mm x 1mm S-Section batten

10Gx16mm hex head self-drilling metal screw



Metal Batten to Frame

12G x 20mm hex head self-drilling metal screw

MORTAR JOINTS

The mortar joints serve an important aesthetic purpose as well as a technical function. The mortar joint provides weathertightness and durability and needs to be sound since the mortar plays an important roll in shielding the supporting sub-structure. A minimum 10mm mortar joint depth is required to maintain appropriate cover and durability.

Note: A raked joint is not to be used with Smartbric Classic.

There are several joint styles to shape the mortar between Smartbric Classic facings and corners:

- Flush Joints - simplest and fastest to shape and recommended
- Rolled/Ironed/Concave Joints - for added compression and strength in the joints.
- Beaded/smudged joints - for a raised and rustic look.

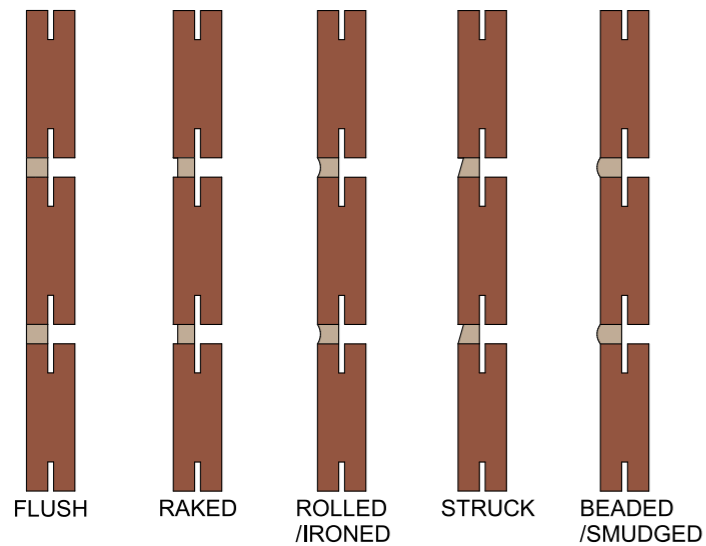

Smartbric Rapid's design incorporates a perimeter recess in the unit itself to create a shadow effect to simulate the look of a raked joint.

MORTAR MIXES

Australian Masonry Standard AS3700 or AS4773.1 set out requirements for mortar mixes.

Mortar Class	Mix Proportions					Mortar Suitability	
	Cement (GB/GP)	Masonry Cement	Builders Lime	Sand	Water Thickener	Fired Clay	Concrete
M2	1	0	2	9	No	Yes	No
M3	1	0	1	6	Optional	Yes	Yes
	1	0	0	5	Yes	Yes	Yes
M4	0	1	0	4	Yes	Yes	Yes
	1	0	0.5	4.5	Optional	Yes	Yes
	1	0	0	4	Yes	Yes	Yes
	1	0	0-0.25	3	Optional	Yes	Yes
	0	1	0	3	Yes	Yes	Yes

NOTES:

1. Type GP = General purpose Portland Cement / Type GB = General purpose Blended Cement
2. Volumes refer to materials in the dense packed state
3. Mortar mixes are designated by the proportions of their ingredients following an initial letter, the chief cementing agent being given as unity (e.g. C1:S4)

Recommended mortar types as per Australian Masonry Standard AS3700 for use with Smartbric are summarised below:

Mortar Class	Durability Class	Mix Proportion by Volume (AS3700)				Smartbric Add-Mix (additive)
		Portland (GP) or Blended Cement (GB)	Builders Lime	Sand		
M3	GP	1	0	5	Yes	
M4	EXP	1	0	4	Yes	

Note: For M3 and M4 mortar mixes a methyl cellulose water thickener can be used in lieu of Smartbric Add-Mix.

Recommended M4 mix quantities are:

- 4 Part 'Brickies' Sand - 20kg
- 1 Part Cement as specified (Grey or White Cement) – 5kg
- 20 grams (approximately 1/2 cap) of Smartbric Add-Mix
 - One cap contains about 50gms of un-compacted Smartbric Add-Mix
 - 80gms of Smartbric Add-Mix per 20kg bag of cement
 - Note: Estimated 4 shovels (5kg) per 20kg bag of cement
 - This is the theoretical additive rate, you may need more depending on atmospheric conditions.

Mix dry ingredients thoroughly before adding water using a drill with mixer attachment or similar.

Slowly add enough water to create a mix that will pass through a mortar gun/ bag without dripping – firm but fluid. NOTE: The water addition rate is sensitive to the climate.

Continue to mix thoroughly using the drill mixer.



Using the appropriate mortar pointing gun, piping bag, or pump (or mortar board and tuck-pointing trowel), inject each joint with mortar mix ensuring the mortar is pushed to the back of the brick facing and proud of the brick face. Mortar joints should be tooled to push the mortar into the joint to completely fill it and then finish off as instructed.

IMPORTANT NOTE: Try not to smear any mortar over the face of the bricks.

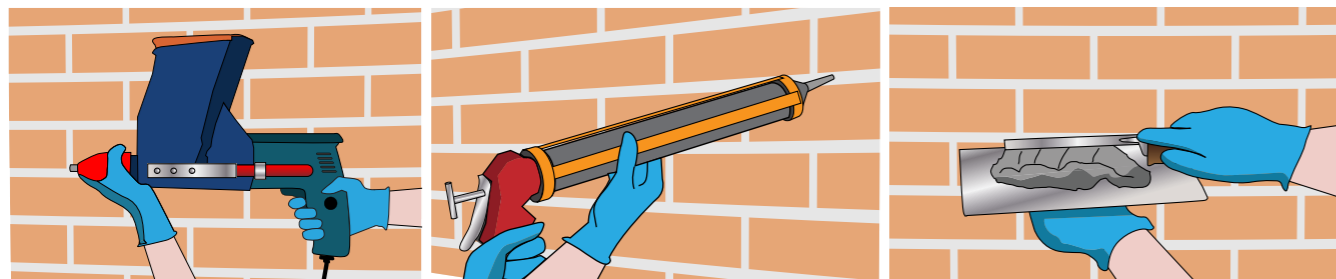

The steps for mortaring are:

1. Fill all joints to back of the track/spacer or rails/spacer
2. Do all vertical joints (perpends) first filling from the bottom up
3. Do Horizontal (bed) joints

NOTE: Overfill and compact your mortar thoroughly to ensure that top and bottom edges of the bricks are wetted and that the mortar fills the depth of the joint. Check that all joints are fully filled. Mortar joints that are not filled correctly should be reworked by filling before the mortar set.

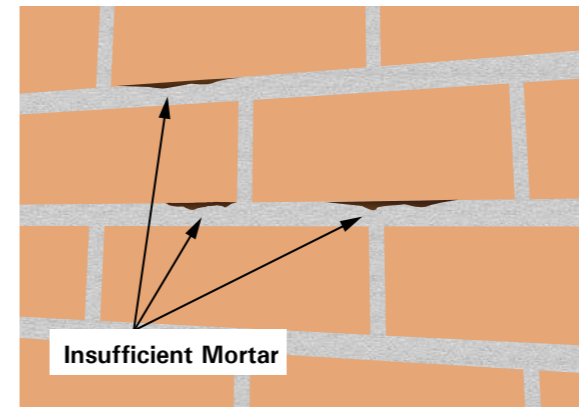

IMPORTANT NOTE: When mortaring a Smartbric into place, inspect the wall and units as you advance. In the event units “stick out” or “stick in” too much or just not straight - **FIX IT NOW** before mortar sets.

4. Mortar should be left to sit and partially dry out prior to tooling.

NOTES:

- Do not allow to dry completely.
- Drying rate will vary with weather conditions - check this often.
- Tool / finish mortar joints as you advance – best to operate as a team with designated responsibilities (pointing, mortar mixing and tooling/finishing).

5. Tool the horizontal & vertical joints.

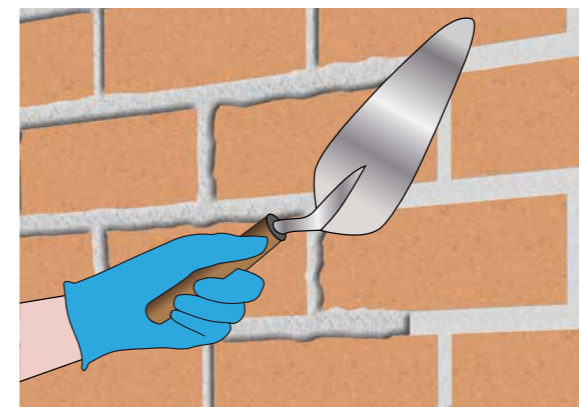

6. Brush off excess mortar when starting to cure (weather dependent). Do not brush it immediately after tooling. Once you've done the tooling in an area let it set a little (but not completely hard) and then brush it down, otherwise you risk smearing the moist edges of the mortar all over the bricks.

- Clean wet mortar off the bricks with a brush using a back-and-forth motion until the mortar dust on the face of your wall is removed.
- Continue to brush each section you advance, but **DO NOT SMEAR MORTAR OVER THE FACE OF THE BRICKS!**

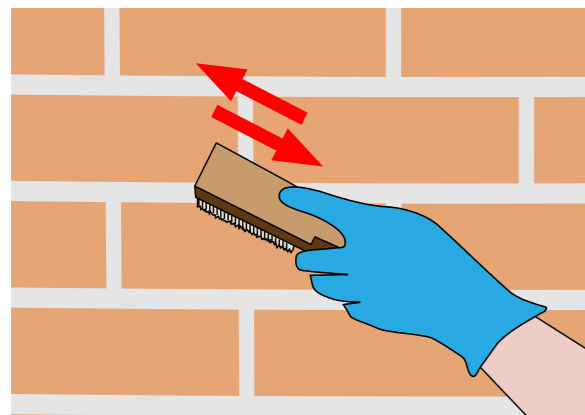

7. Clean off any excess mortar or mortar smears from bricks with a moist sponge or a vinegar solution (a mild acid) prior to drying and hardening.

NOTE: Once mortar dries and is sufficiently hardened, it can only be removed by tools or mechanical means (scutch hammer) and controlled high pressure water jet spray (or acid wash if absolutely necessary).

Cleaning to done with non-acid based cleaners wherever possible.

Allow mortar to sufficiently hardened (allow at least 3 days) to ensure that mortar in joint is not disturbed or damaged during cleaning. Remove any excess hardened mortar by mechanical means and / or controlled high pressure fan jet water spray (or mild acid wash only as a last resort).

When using a high-pressure water jet spray, ensure that pressure is kept below 1000 psi to prevent damage to either the mortar or brick facing. Working from top to bottom of wall using a water jet spray angle at 15 degrees concentrate the pressure on the brick facings and not on the joint and scrub off any remaining mortar using a thick bristled brush.

Where an acid wash is used, ensure through rinsing as acid is corrosive and can damage sub-frame components. Where mild acid solutions are required, openings and voids are to be masked and blocked to prevent ingress of chemical solution behind the masonry façade and that may come into contact with the metal sub-frame.

8. Curing - Allow mortar to cure for at least 7 days.

CAUTION: Mortar Staining

Avoid smearing mortar into brick surface as this can lead to staining of the brick and a blemished appearance even after cleaning since the mortar permeates into the porous and absorbent brick. Where contrasting colours are used such as a black grout on a light-coloured brick, bricks a far more susceptible to staining.



SMARTBRIC® ADD-MIX

Smartbric Add-Mix is a concentrated powder plasticizer for cement-based mortars.

It is designed to provide improved workability and water-retention characteristics in mortars for use with the Smartbric Rainscreen Masonry Façade System.



FEATURES AND BENEFITS

Smartbric Add-Mix replaces the use of air entraining additives (AEA), hydrated lime, and/or water retention additives in cement-based mortars. Its water retention properties aid in lower water absorption and help to reduce premature drying of mortar at the substrate-cladding interface, resulting in measurably higher bond strengths. The product provides improved workability, allows longer working life, and makes mortar suitable for use with grouting mortar guns or similar mortar grouting devices.

DIRECTIONS & USAGE RATES

The following should only be used as a guide only. Installer must adhere to Australian Standards, BCA requirements, and best practice when pointing masonry with Smartbric Redi-Mix. For detailed application instructions, refer to the Technical Data Sheet (TDS), available at www.fv.com.au.

WHAT YOU'LL NEED

- Mortar Pointing Gun (or similar grouting device) typically:
 - Grouting Mortar Gun Drill style attachment*
 - Barrel Style Caulking Gun (manually operated)
- Trowel or scoop
- Gloves
- Eye Protection
- Wash up

*Use of a Repointing and Grouting Mortar Gun is recommended and as their use can be up to 5 times faster and less tiring than conventional pointing methods. Alternatively, pointing (piping) bags or traditional mortar and tuck-pointing trowel may be used.

YIELD RATES

- 80gms Smartbric Add-Mix per 20kg of cement
- 4kg pail Smartbric Add-Mix per 1000kg bags of cement
- One cap (supplied) contains about 50gms of un-compacted Smartbric Add-Mix

The use of 80gms of Smartbric Add-Mix per 20kg bag of GP, Builders, or off white cement will enhance sand and cement mortars and provide performance improvements as suggested by Australian Standard 3700 Masonry Structures Code. Depending on constituent sand quality the dosage may be modified by +/- 20gms per 20kg of cement, to optimise performance.

Recommended mortar types as per Australian Masonry Standard AS3700:

Mortar Class	Durability Class	Mix Proportion by Volume (AS3700)			
		Portland (GP) or Blended Cement (GB)	Hydrated Lime	Sand	Smartbric Add-Mix
M3	GP	1	0	5	Yes
M4	EXP	1	0	4	Yes

Mix the required amount of Smartbric Add-Mix with cement before blending with other materials

APPLICATION – USING A MORTAR GUN DRILL TYPE ATTACHMENT FOR BATTERY SCREW GUN TOOL

1. Ensure wall is clean, safe and ready for mortar application. Ensure that spacers are in position and secure. It is advisable to use at least 2 persons for the grouting process - One operator to apply grout whilst the second loads the grouting tool, finishes joints and cleans progressively.
2. Mix the required amount of Smartbric Add-Mix with cement then mix in other materials. DO NOT over-dose mortar with Smartbric Add-Mix. Ensure that good working mortar consistency is achieved.
3. Ensure grouting tool is secured to screw gun or drill.
4. Fit appropriate pointing nozzle or grout nozzle to the grouting tool
5. Fill grouting tool hopper with prepared mortar.
6. Extrude mortar into joints starting with the vertical (perpend) joints followed by the horizontal (course) joints. It is recommended that working area be limited to approximately one square metre at a time. This will make for easier tooling and progressive cleaning.
7. Ensure that mortar is extruded at a consistent rate and that the material is pushed firmly into joint making contact with all sides of the joint. Allow sufficient material to slightly over-fill the joints allowing easier tooling and finishing.
8. Remove and smooth off any excess mortar using a trowel. Ensure the edge of the brick joint is fully coated/filled. Any voids or depressions can be topped up by re-trowelling.
9. Joints can be tooled as required using appropriate pointing tools and techniques. Avoid excessive removal of mortar or raked joints. Flush joints are recommended.
10. Smooth off any excess pointing material.
11. Regularly clean grouting tool with water between reloads to avoid build-up and hardening of mortar in the equipment. Hardened material can accelerate the set time of subsequent batches.
12. Clean surface, tools and equipment using water and a sponge before mortar skins or hardens, otherwise conventional brick cleaning techniques* can be used.

*Conventional brick cleaning techniques typically use acid to remove dried mortar and as such their use, should be minimised to avoid potential damage to metal mounting system.

SMARTBRIC REDI-MIX

Smartbric Pre-Mixed Polymer Modified Flexible Mortar



Smartbric Redi-Mix Polymer Modified Flexible Mortar was developed and tested as a pointing mortar for the Smartbric ventilated rainscreen Brick Façade System. Tested to AS4284-2008: Testing of building facades, the pre-mixed polymer modified mortar provides excellent bond and weather exposure performance.

Smartbric Redi-Mix provides an authentic mortar pointing look with-out the shortcomings or restraints of traditional mortars. The polymer modified formulation ensures consistency, ease of use and good workability.

Smartbric Redi-Mix Flexible Pointing is a synthetic mortar specially developed for brick masonry pointing. It has excellent mortar texture and fatigue loading characteristics after conditioning by prolonged water saturation (as per Australian Standard AS4046.8- 2015).

Once cured, Smartbric Redi-Mix flexible pointing forms an incredibly strong and durable bond between the masonry units and excellent adhesion to the metallic track or rail framing system.

Product is available in a 10L pail in a range of colours (including Neutral) to match an extensive range of masonry bricks supplied by Fairview.

TECHNICAL DATA/PROPERTIES - PROPERTY TYPICAL RESULT

Colour	Various
Density	1.35
Technology	Acrylic
Application Temperature	10-40°C
Shelf Life	24 months
Working Time	10-20 minutes @ 40°C
Cure Time	24 Hours
Tensile Strength	0.9 MPa
VOC	10g/L
Coverage (Approx)	100LM per 10L pail (allow for waste) 500 bricks 10m ² (based on 50 bricks /m ²)

FEATURES/ADVANTAGES

Smartbric Redi-Mix Polymer Modified Flexible Mortar

- Alternative to conventional cement mortar and pointing
- Fast same day installation
- Non-corrosive - suitable for use with aluminium rail
- Excellent durability and weather resistance
- Strong and durable bonding - between brick facings and mounting system
- Excellent fatigue loading (meets requirements of AS4046.8-2015)
- Non-sag thixotropic formulation
- Flexes with normal wall movement without cracking or breaking away
- Smooth formula makes it easy to mix and apply
- Water clean-up

APPLICATION INSTRUCTIONS – USING A MANUAL POINTING GUN*

1. Ensure wall is clean, safe and ready for mortar application. Ensure that spacers are in position and secure. It is advisable to use at least 2 persons for the grouting process - one operator to apply grout whilst the second loads the grouting tool, finishes joints and cleans progressively.
2. Mix content. Using a trowel mix the product until a slightly wet consistency is achieved. DO NOT over work/mix.
3. Fit appropriate pointing nozzle or grout nozzle to the barrel tube (cylinder)
4. Scoop Smartbric Redi-Mix into the barrel tube of the for dispensing apparatus.
5. Load tube into the skeleton caulking gun.
6. Extrude Smartbric Redi-Mix Extrude mortar into joints starting with the vertical (perpend) joints followed by the horizontal (course) joints. It is recommended that working area be limited to approximately one square metre at a time. This will make for easier tooling and progressive cleaning.
7. Ensure that Smartbric Redi-Mix is extruded at a consistent rate and that the material is pushed firmly into joint contacting all sides of the joint. Allow sufficient material to slightly over-fill the joints allowing easier tooling and finishing. Minimum thickness no less than 3 to 5mm

8. Remove and smooth off any excess Smartbric Redi-Mix using a trowel. Ensure the edge of the brick joint is fully coated/filled. Any voids or depressions can be topped up by re-trowelling. Avoid re-using skinned/hardened or contaminated material that may clog the mortar pointing tool.
9. Joints can be tooled as required using appropriate pointing tools and techniques. Avoid excessive removal of mortar or raked joints. Flush joints are recommended.
10. Smooth off any excess mortar material. You can mix Smartbric Redi-Mix to a 'wetter' consistency to fill any gaps or air holes
11. Mix the product further to achieve a thinner consistency for pointing adhesive (as required). Never add water to restore trowelling ability.
12. Clean-up using water and moist sponge ensure that any undesired surface residual material is removed before it skins or hardens, otherwise it will be difficult to remove once set.

*NB! Use of a Repointing / Grouting Mortar Gun drill attachment device is not recommended as compound can clog the mechanism upon skinning or hardening.

OPEN TIME: The expected open time is 10-20 minutes before the product starts to skin.

COVERAGE: One 10 litre bucket of Smartbric Redi-Mix provides approximately 100 lineal meters of pointing based on a 10mm x 10mm mortar joint. 50 bricks require approximately 10 lineal metres per square metre of pointing and minimal wastage - Allow for wastage.

OPTIMAL TEMPERATURE RANGE: DO NOT use the product below 15°C or above 40°C. Use a proprietary retardant if needed.

Smartbric Redi-Mix is a water-based product and requires the water to evaporate before it will harden. Although 2 hours drying in good weather is sufficient for the product to develop a skin that will resist light rain. In cold and wet conditions drying time is often extended and it may take some days before it is resistant to persistent or heavy rain. A fast surface skin resistant to light/showery rain can be achieved by spraying the pointing surface lightly with a proprietary accelerant spray immediately after pointing.

CLEAN UP: Spills and tools can be cleaned up with water or mineral turps before product cures

STORAGE: Store unopened pails below 30 C in a cool dry place away from direct sunlight. Unopened pails can be stored for 24 months from the date of manufacture. Opened pails may skin at the surface. Discard any lumps or skin and remaining product can be used

- No special personal protective equipment required.
- Wash hands after use. Rubber gloves are recommended if handling often.
- Not classified as Dangerous Goods.
- Not classified as Hazardous.
- Refer to (MSDS) Safety Data Sheet for more detailed information.

GROUTING TOOLS

Mortar can be applied to the joints by several methods depending on the size of the job and the tools one has available:

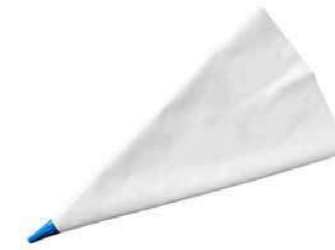

REUSABLE PIPING BAGS



MORTAR POINTING AND GROUTING GUN – MANUALLY OPERATED



MORTAR GUN (DRILL ATTACHMENT)



MORTAR CAULKING GUN - PUMP



DISPOSABLE PIPING BAG – FOR VERY SMALL JOBS OR TOUCH-UPS

SMARTBRIC GENERAL LAYOUT AND CUTTING

Brick laying is truly an art form that must be approached with attention to detail, a plethora of knowledge and all the right materials. Building a wall using Smartbric is a job for a skilled tradesman and an understanding of general brick-laying practices will come in useful when setting out and detailing a job. The proper preparation and planning can make a significant difference between an average job and an outstanding one.

Despite a designer's best endeavours, Smartbric individual brick facings may require some cutting to fit into place. Some judgement may be required to ensure that any odd size brick or odd detail becomes inconspicuous. Check that brick spacings work and the arrangement is well balanced so as to require minimal cutting. If necessary, spread facings a little to take up a gap or tighten up perpend joints if necessary.

NOTE: Bricks are not completely uniform in length (or height) so don't try to gauge the facings accurately with a 10mm joint measure.

Installation of the Smartbric facings is relatively fast and straight forward by following the following key steps:

- Lay the corner bricks first.
- Lay facings from the bottom of the wall up.
- Line up perpendicular (vertical joints) up as you go.
- Check the wall as you go.
- Fix any issues as you advance.

When installing Smartbric between corners and openings (such as doors and windows), the alignment of the perpend joint in this section can be considered independent of other areas. If a cut facing is required to work the facings between two openings use a $\frac{3}{4}$ (approximately 170mm) wherever possible, the same size facing should be used in course above and below the same area. Avoid facings that are cut to less than a half facing (110mm) wherever possible.

Having perpend joints aligned immediately above each other or in very close proximity in adjoining brick courses produces an unsightly appearance with inappropriate proportions and is something a skilled brick layer would avoid doing.

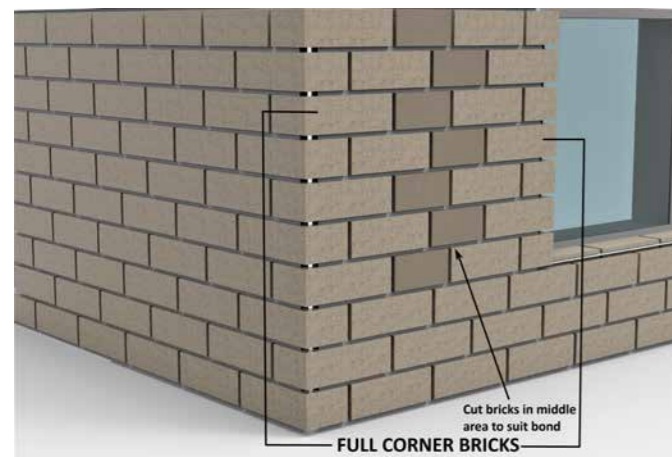

Use halves and full facings down the sides of windows and doors. Avoid cutting corners unless absolutely necessary.

Where Smartbric facings need to match existing brickwork using the traditional 7 courses per 600mm rise, a "creeper" track can be supplied to provide a variable gauge set-out. Coursing charts are provided below. When using the Smartbric rail, rails can be spaced to align with existing brickwork.

COURSING CHARTS

REGULAR BRICK / TRACK SYSTEM WITH CREEPER TRACK STANDARD BRICK

BRICKS PER M² IN WALL: 48.5
 FORMAT SIZE: 240mm x 120mm x 86mm
 MANUFACTURING SIZE: 230mm x 110mm x 76mm
 VERTICAL GAUGE: 7 Courses to 600mm

ALL DIMENSIONS IN MILLIMETRES

NO. OF BRICKS	HEIGHT	LENGTH	OPENING	NO. OF BRICKS	HEIGHT	LENGTH	OPENING*
1	86	230	250	26	2229	6230	6250
1.5		350	370	26.5		6350	6370
2	172	470	490	27	2314	6470	6490
2.5		590	610	27.5		6590	6610
3	257	710	730	28	2400	6710	6730
3.5		830	850	28.5		6830	6850
4	343	950	970	29	2486	6950	6970
4.5		1070	1090	29.5		7070	7090
5	429	1190	1210	30	2572	7190	7210
5.5		1310	1330	30.5		7310	7330
6	514	1430	1450	31	2657	7430	7450
6.5		1550	1570	31.5		7550	7570
7	600	1670	1690	32	2743	7670	7690
7.5		1790	1810	32.5		7790	7810
8	686	1910	1930	33	2829	7910	7930
8.5		2030	2050	33.5		8030	8050
9	772	2150	2170	34	2914	8150	8170
9.5		2270	2290	34.5		8270	8290
10	857	2390	2410	35	3000	8390	8410
10.5		2510	2530	35.5		8510	8530
11	943	2630	2650	36	3086	8630	8650
11.5		2750	2770	36.5		8750	8770
12	1029	2870	2890	37	3172	8870	8890
12.5		2990	3010	37.5		8990	9010
13	1114	3110	3130	38	3257	9110	9130
13.5		3230	3250	38.5		9230	9250
14	1200	3350	3370	39	3343	9350	9370
14.5		3470	3490	39.5		9470	9490
15	1286	3590	3610	40	3429	9590	9610
15.5		3710	3730	40.5		9710	9730
16	1372	3830	3850	41	3514	9830	9850
16.5		3950	3970	41.5		9950	9970
17	1457	4070	4090	42	3600	10070	10090
17.5		4190	4210	42.5		10190	10210
18	1543	4310	4330	43	3686	10310	10330
18.5		4430	4450	43.5		10430	10450
19	1629	4550	4570	44	3772	10550	10570
19.5		4670	4690	44.5		10670	10690
20	1714	4790	4810	45	3857	10790	10810
20.5		4910	4930	45.5		10910	10930
21	1800	5030	5050	46	3943	11030	11050
21.5		5150	5170	46.5		11150	11170
22	1886	5270	5290	47	4029	11270	11290
22.5		5390	5410	47.5		11390	11410
23	1972	5510	5530	48	4114	11510	11530
23.5		5630	5650	48.5		11630	11650
24	2057	5750	5770	49	4200	11750	11770
24.5		5870	5890	49.5		11870	11890
25	2143	5990	6010	50	4286	11990	12010
25.5		6110	6130	50.5		12110	12130

*To find the length of an opening (a given number of units long) add 20 to above figures

**FIXED GAUGE TRACK - THROUGH-OUT
STANDARD BRICK**

BRICKS PER M² IN WALL: 48.5
 FORMAT SIZE: 240mm x 120mm x 86mm
 MANUFACTURING SIZE: 230mm x 110mm x 76mm
 VERTICAL GAUGE: 7 Courses to 602mm

ALL DIMENSIONS IN MILLIMETRES

NO. OF BRICKS	HEIGHT	LENGTH	OPENING	NO. OF BRICKS	HEIGHT	LENGTH	OPENING*
1	86	230	250	26	2229	6230	6250
1.5		350	370	26.5		6350	6370
2	172	470	490	27	2322	6470	6490
2.5		590	610	27.5		6590	6610
3	258	710	730	28	2408	6710	6730
3.5		830	850	28.5		6830	6850
4	344	950	970	29	2494	6950	6970
4.5		1070	1090	29.5		7070	7090
5	430	1190	1210	30	2580	7190	7210
5.5		1310	1330	30.5		7310	7330
6	516	1430	1450	31	2666	7430	7450
6.5		1550	1570	31.5		7550	7570
7	602	1670	1690	32	2752	7670	7690
7.5		1790	1810	32.5		7790	7810
8	688	1910	1930	33	2838	7910	7930
8.5		2030	2050	33.5		8030	8050
9	774	2150	2170	34	2924	8150	8170
9.5		2270	2290	34.5		8270	8290
10	860	2390	2410	35	3010	8390	8410
10.5		2510	2530	35.5		8510	8530
11	946	2630	2650	36	3096	8630	8650
11.5		2750	2770	36.5		8750	8770
12	1032	2870	2890	37	3182	8870	8890
12.5		2990	3010	37.5		8990	9010
13	1118	3110	3130	38	3268	9110	9130
13.5		3230	3250	38.5		9230	9250
14	1204	3350	3370	39	3354	9350	9370
14.5		3470	3490	39.5		9470	9490
15	1290	3590	3610	40	3440	9590	9610
15.5		3710	3730	40.5		9710	9730
16	1376	3830	3850	41	3526	9830	9850
16.5		3950	3970	41.5		9950	9970
17	1462	4070	4090	42	3612	10070	10090
17.5		4190	4210	42.5		10190	10210
18	1548	4310	4330	43	3698	10310	10330
18.5		4430	4450	43.5		10430	10450
19	1634	4550	4570	44	3784	10550	10570
19.5		4670	4690	44.5		10670	10690
20	1720	4790	4810	45	3870	10790	10810
20.5		4910	4930	45.5		10910	10930
21	1806	5030	5050	46	3956	11030	11050
21.5		5150	5170	46.5		11150	11170
22	1892	5270	5290	47	4042	11270	11290
22.5		5390	5410	47.5		11390	11410
23	1978	5510	5530	48	4128	11510	11530
23.5		5630	5650	48.5		11630	11650
24	2064	5750	5770	49	4214	11750	11770
24.5		5870	5890	49.5		11870	11890
25	2150	5990	6010	50	4300	11990	12010
25.5		6110	6130	50.5		12110	12130

*To find the length of an opening (a given number of units long) add 20 to above figures

CORNERS

There are several options when it comes to external and internal corner detailing. Smartbric Classic has matching corner units, whereas extruded Smartbric Rapid (and extruded Smartbric Classic) require cutting to make a corner. A brick cutting saw will be required when bricks require cutting.

Extruded internal and external aluminium trim mouldings are also available that greatly simplify corner detailing and require only square saw cut to trim to size.

Trim – External and Internal Corners

Internal and external extruded aluminium trims are available to accentuate the design. Furthermore, the use of trim can speed up construction by simplifying the assembly and essentially reduce any cutting of bricks to simply a straight cut.

INTERNAL CORNERS

Corners can be achieved using either a butt or mitred joint. Conventional internal brick corners can simply be achieved by overlapping bricks at 90° to achieve a realistic internal corner look. In most cases an internal mitred corner requires additional time and processing and is considered unnecessary. Mitred internal corners can be formed by butting two saw cutting brick facings at 45° if desired.

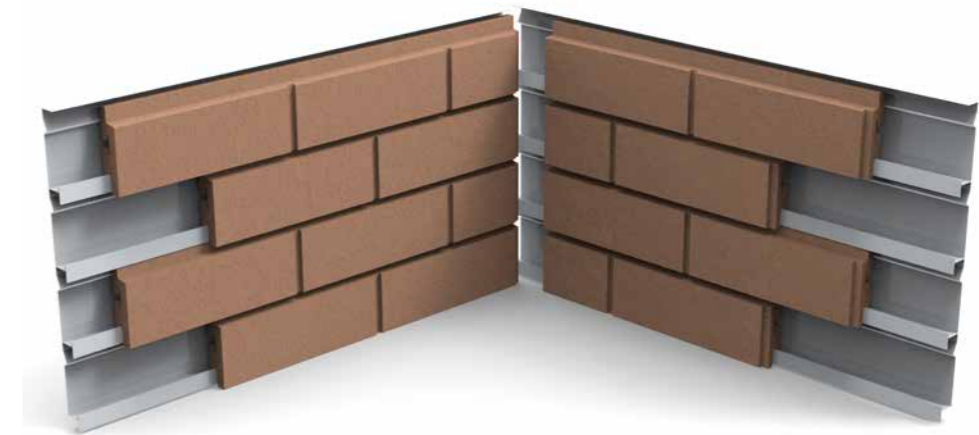

Note: Open internal corner shown for clarity

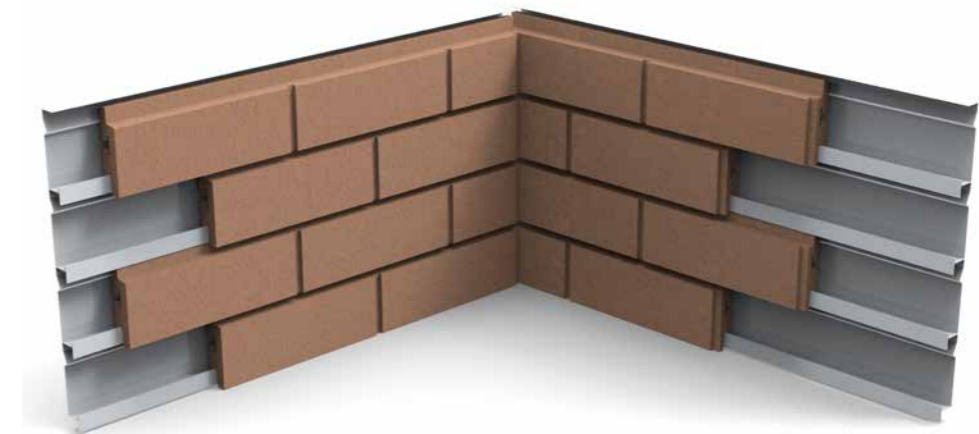

EXTERNAL CORNERS

Corners can be achieved using either a butt or mitred joint. Note however that butt joints expose the thickness of the facing and this needs to be given due consideration when used. Mitred corners can simply be achieved by making a saw cutting at 45°.

In order to reproduce the appearance of a regular brick corner, the two adjoining faces need to be cut to 230mm and 110mm respectively and assembled to mimic an actual brick corner.

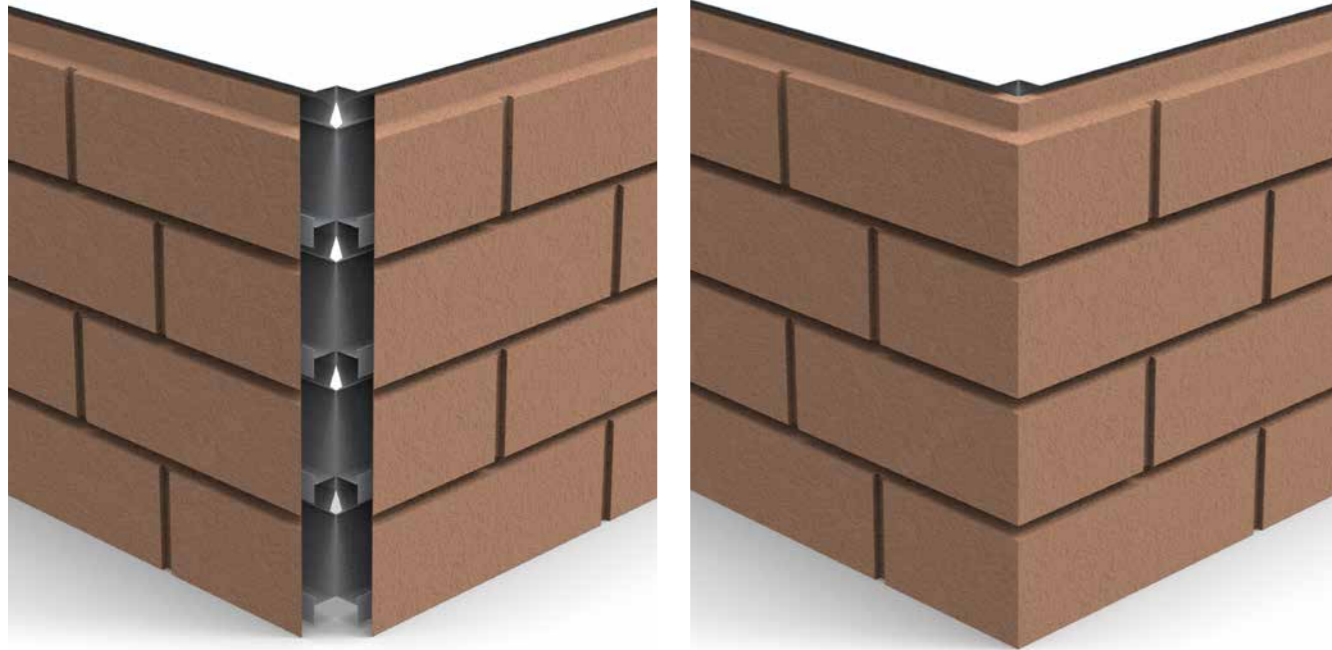

Note: Open internal corner shown for clarity

The external corners track assembly is stiffened by fixing a corner angle (50mm x 50mm x 0.55mm minimum thickness) behind the track using a corner fixing pattern as shown below.



SMARTBRIC CLASSIC - MITRES AND DETAILING

Smartbric Classic brick facings can simply be mitred cut using a conventional wet brick saw to achieve a mitred butt look and a realistic looking corner unit.



SMARTBRIC RAPID - MITRES AND DETAILING



A brick joiner (available as an accessory) can be used to connect Smartbric Rapid brick facings and to form a corner assembly.

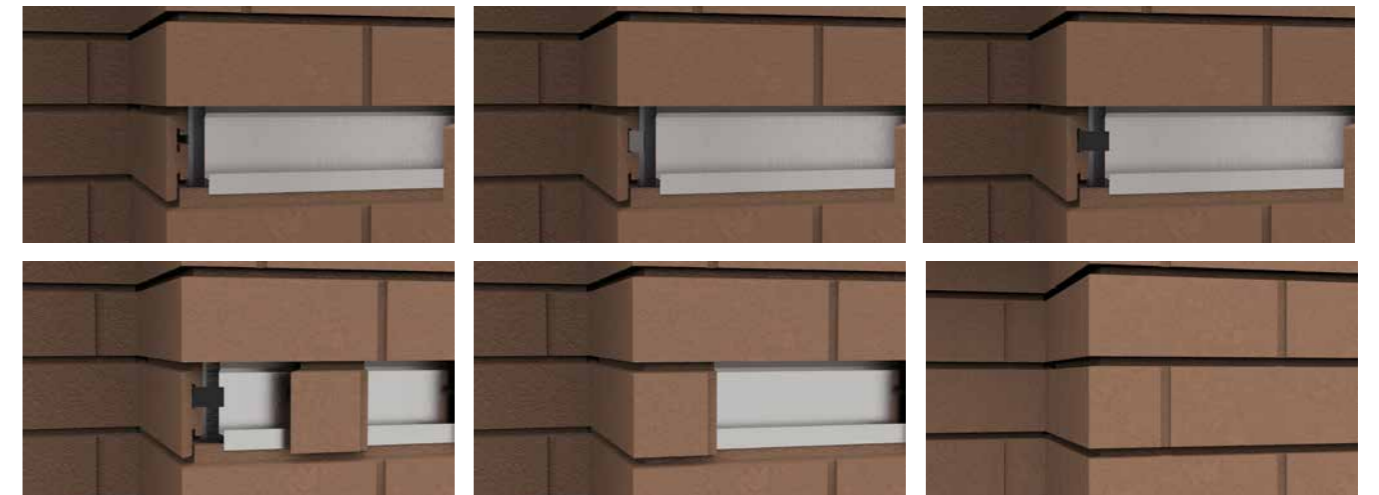

A standard Smartbric Classic corner piece (with a 10.5mm thick return) is specifically designed to fit track and rail (without any need to notch track or rail).

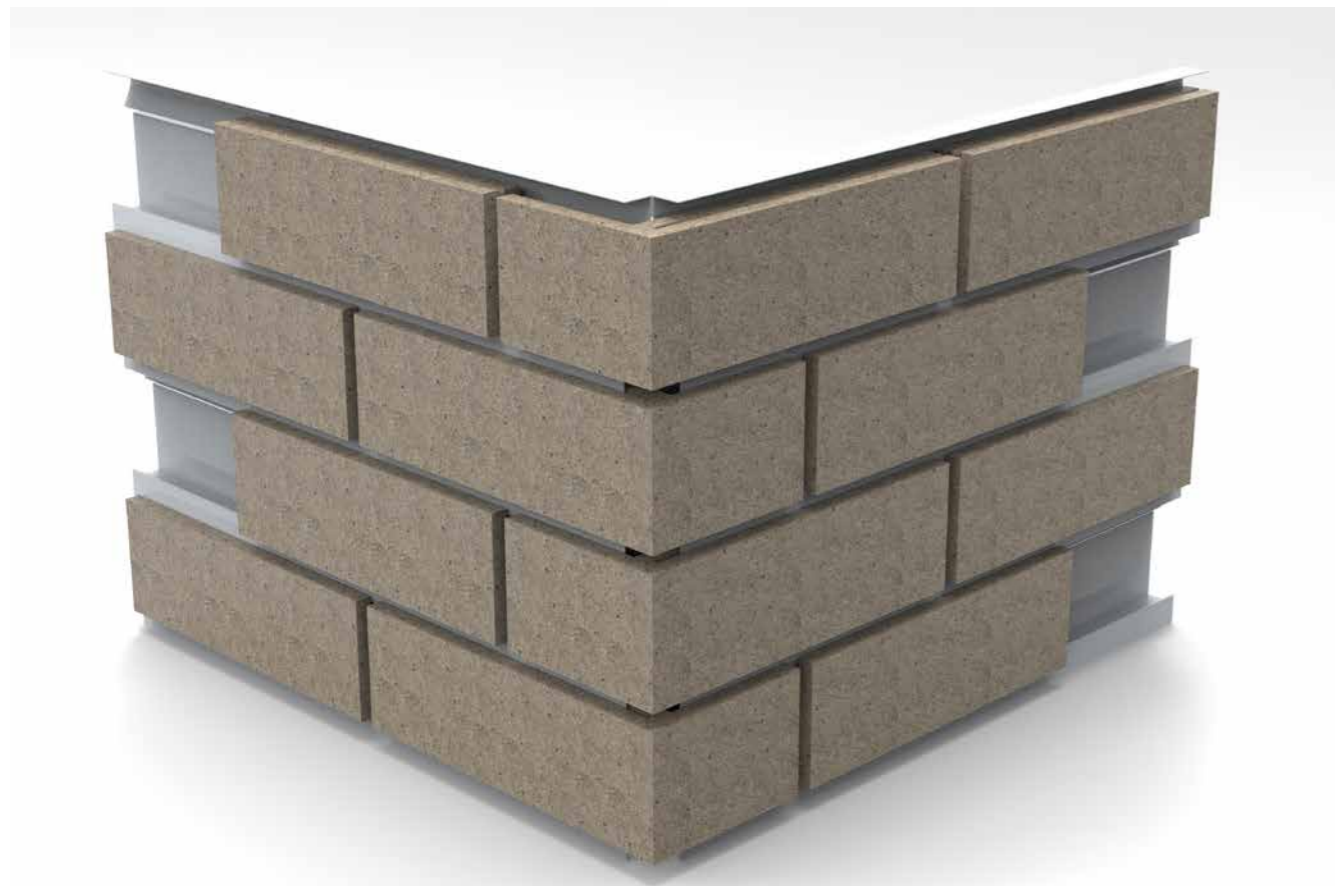

NOTE: Smartbric Track and Rail System will require notching to accommodate a Smartbric corner (with grooved 25mm thick return) or pre-formed corner unit to enable assembly. Alternate and adjacent rows of track/rail are to be notched in a staggered arrangement.



SMARTBRIC RAPID LOCKING – USE OF JOINER

A brick joiner (available as an accessory) can be used to connect Smartbric Rapid brick facings by simply inserting the joiner piece in the rear groove of the unit and pushing Rapid facing units together.

By locking Rapid units together by use of a joiner provides an added security feature that makes removal of the Rapid unit difficult when a standard Smartbric track or standard gauge rail spacing is used.

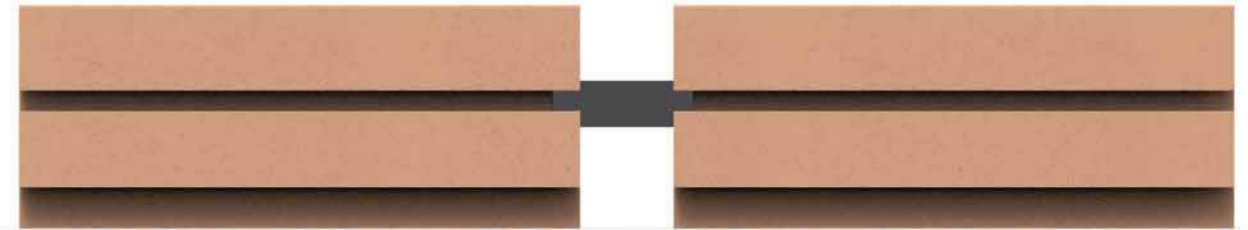

Insert spacer into rear groove

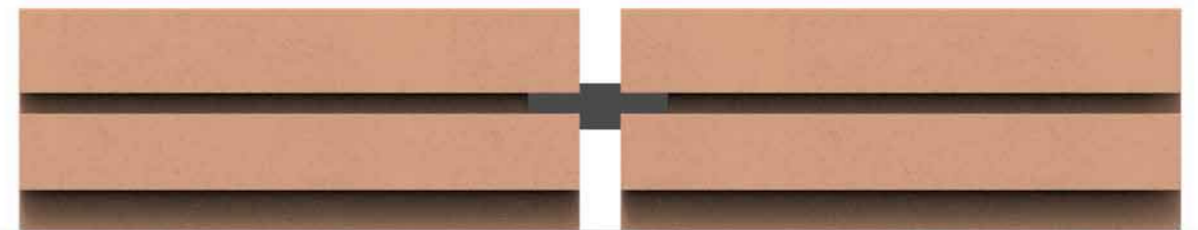

Push units together



Lock units into position

SMARTBRIC RAPID UNIT CAPTURE - TRACK MODIFICATION

The use of a standard Smartbric track or standard gauge rail spacing configuration provides the advantage of construction speed as facings can be simply installed using the tilt, lift and engage methodology with track or rail, and can also be easily removed or replaced as required.

When greater permanency or added security is required, the Smartbric Rapid (and Classic) can be secured into position to resist movement (e.g. soffits) or prevent removal by making a simple track modification. By notching (cutting), a tab in the Smartbric track's lower tongue and folding the tab sufficiently for the tab to push against the top of the facing when inserted to resist movement and removal.



Notching of the Smartbric track's top alignment fold is also possible for locking units into position. Note that when top alignment fold is used for this purpose, tabs need to be folded as required and tracks stack sequentially or tabs need to be folded prior to subsequent tracks being installed/stacked.

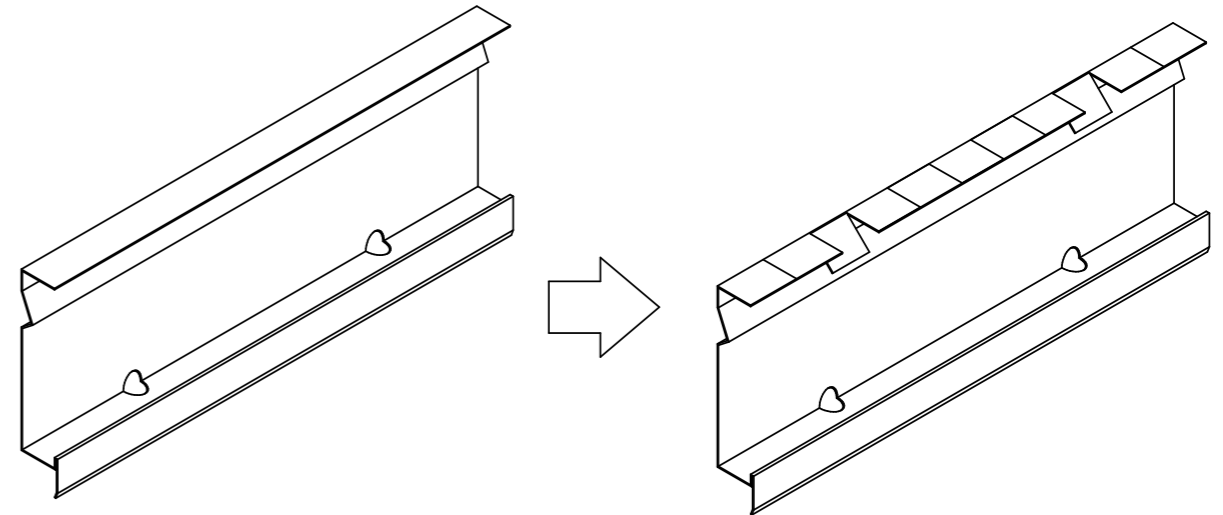

Tab notching tools are available for purchase from specialist sheet metal suppliers.

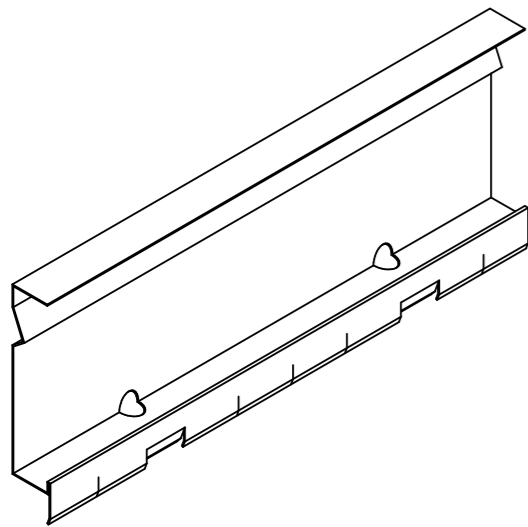

TRACK TAB FOLDED DOWN FOR LOCKING

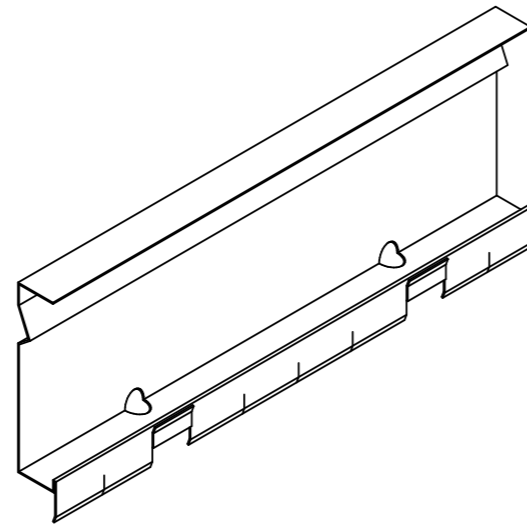

TRACK TAB FOLDED UP TO REDUCE MOVEMENT

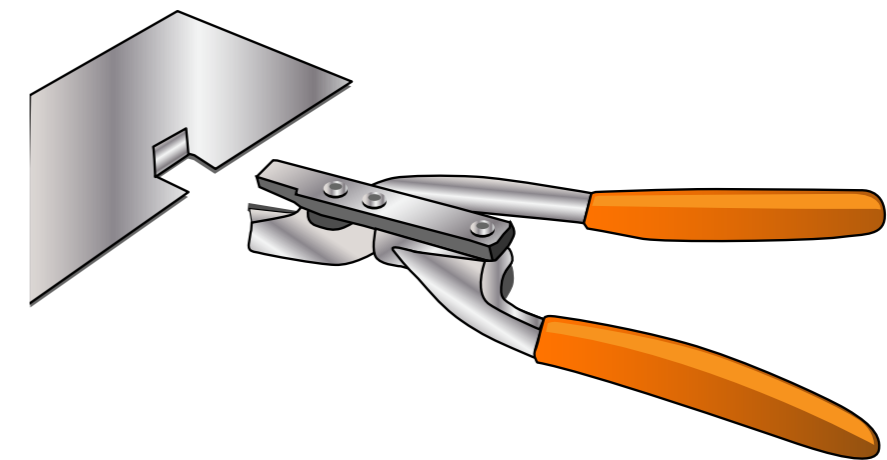

ADDITIONAL VIBRATION REDUCTION TECHNIQUES – HIGH WIND AREAS

A number of techniques can be utilised to reduce movement or vibration (and noise) that may result from high winds or pressure. These include:

- Sealants – used to form a gasket
- Joiners – used to provide interlock between units
- Track modification – using notches to lock units into position
- Rail spacing – adopt a close gauge spacing to lock and limit movement potential of the unit.
- Rail positioning – engaging the centre groove in the Rapid unit where practical

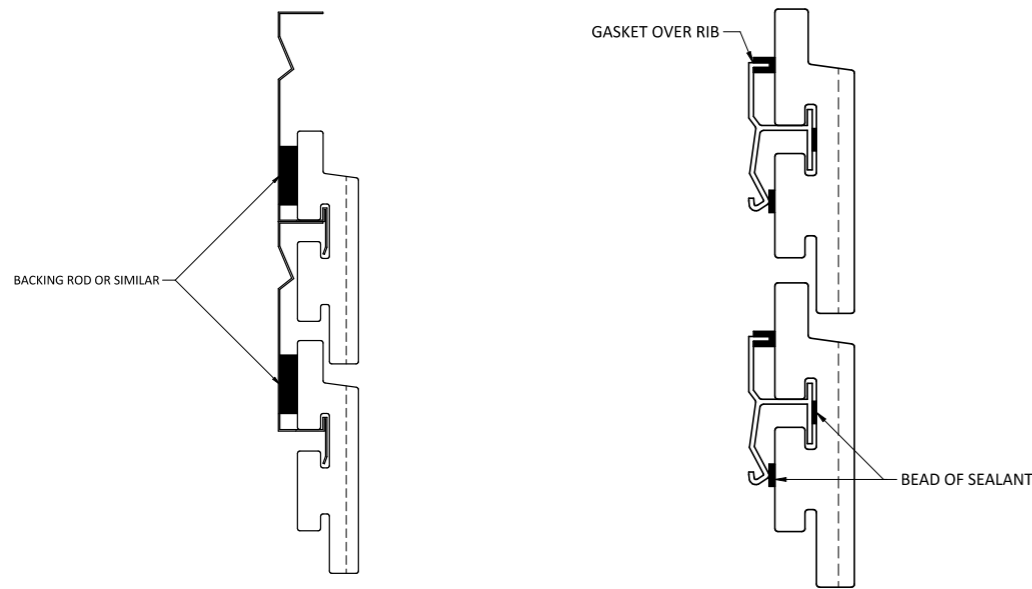

SMARTBRIC CLASSIC AND TRACK INSTALLATION – OVERVIEW

FIXING PATTERN – TRACK

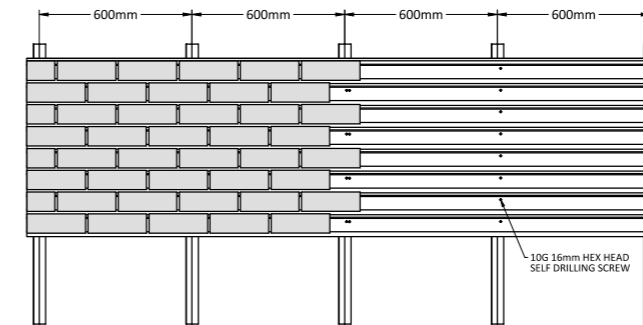

FIXING PATTERN – RAIL

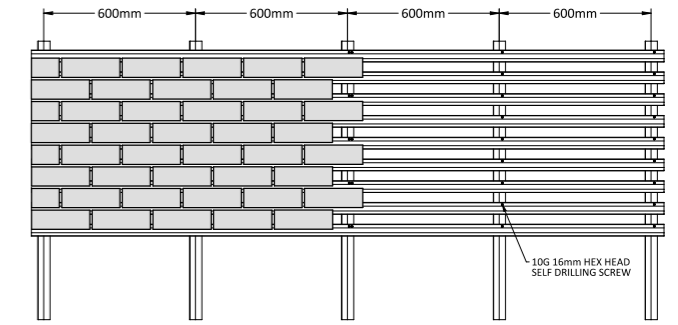

FRAME ASSEMBLY – STAGES

The key stages of installation are summarised below showing the fundamental sequence of the Smartbric system assembly.



Installation drawings are provided below detailing the various wall and junction assembly details. The assembly details provided are not exhaustive and project specific details may be required depending on the unique design specifics of a particular project. In addition, other practical solutions not outlined in this document may be possible. Contact Fairview for additional advice.

Where design and installation details fall outside scope of this document it is recommended that a small-scale mock-up or prototype be build specific to the project to ensure feasibility of construction. The project engineer/designer must check and confirm that the nominal joint size is sufficient to accommodate expected building movements and deflections, thermal expansion and contraction of materials. Accordingly, joint sealants shall have sufficient movement capacity to also accommodate these movements and weatherproofing requirements.

Please note, dimensions and tolerances provided are nominal and accurately represent the majority of products but may differ for certain product ranges and for any custom-made product. Please contact Fairview for more information.

FINAL DESIGN AND CERTIFICATION OF ALL ELEMENTS TO THE INSIDE OF THE SMARTBRIC TRACK OR RAIL TO BE CARRIED OUT BY THE PROJECT DESIGN PROFESSIONAL.

SMARTBRIC - TYPICAL WALL PROFILES

COMPLETE WALL SYSTEM
SMARTBRIC RAPID AND RAIL

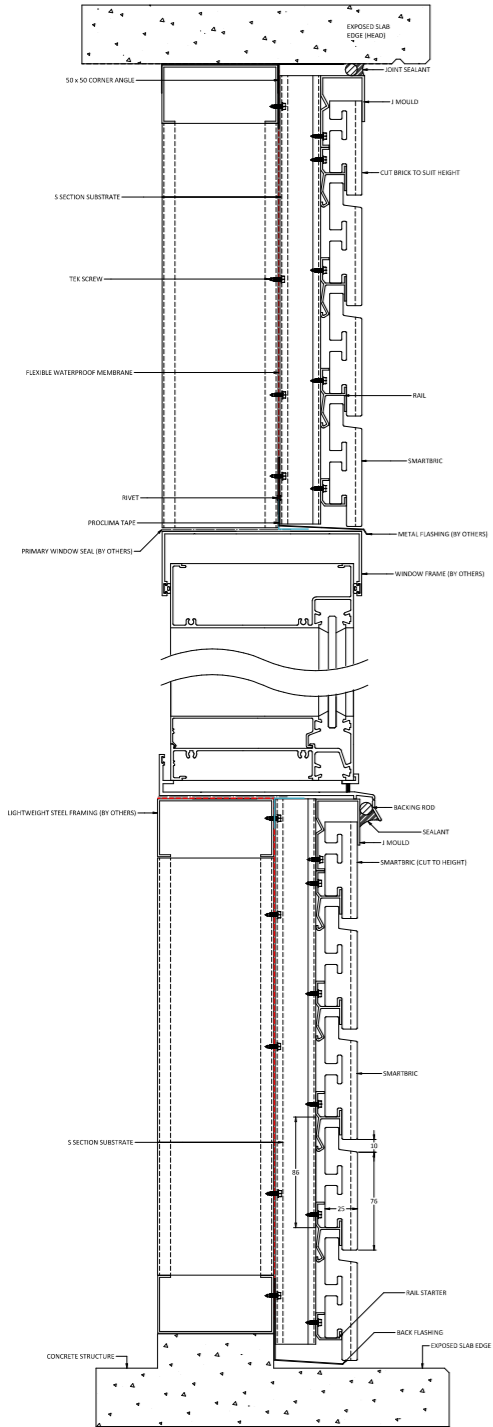

COMPLETE WALL SYSTEM
SMARTBRIC RAPID AND TRACK

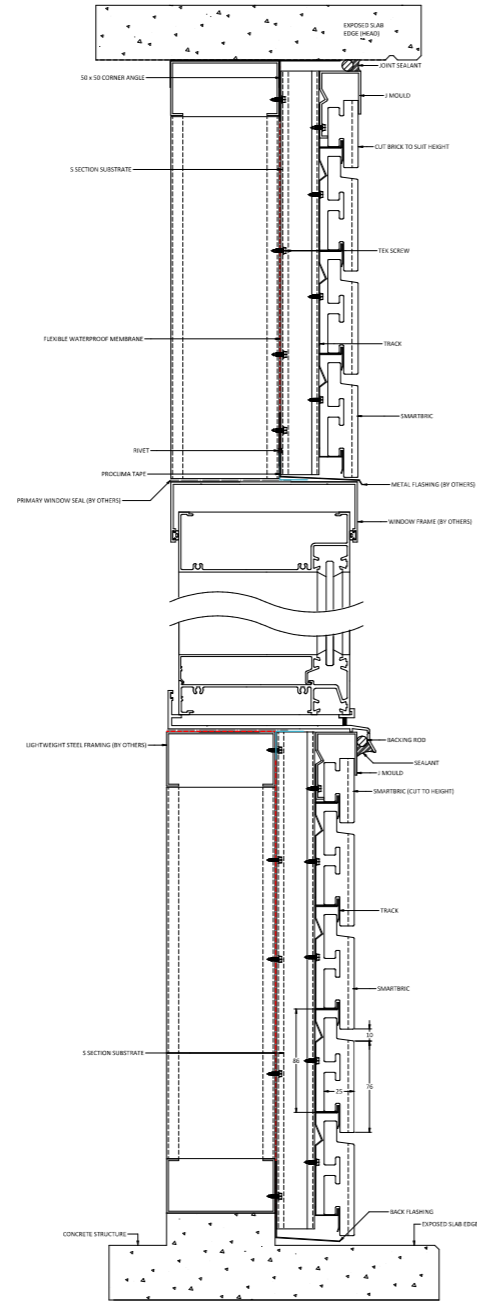

COMPLETE WALL SYSTEM
SMARTBRIC CLASSIC AND RAIL

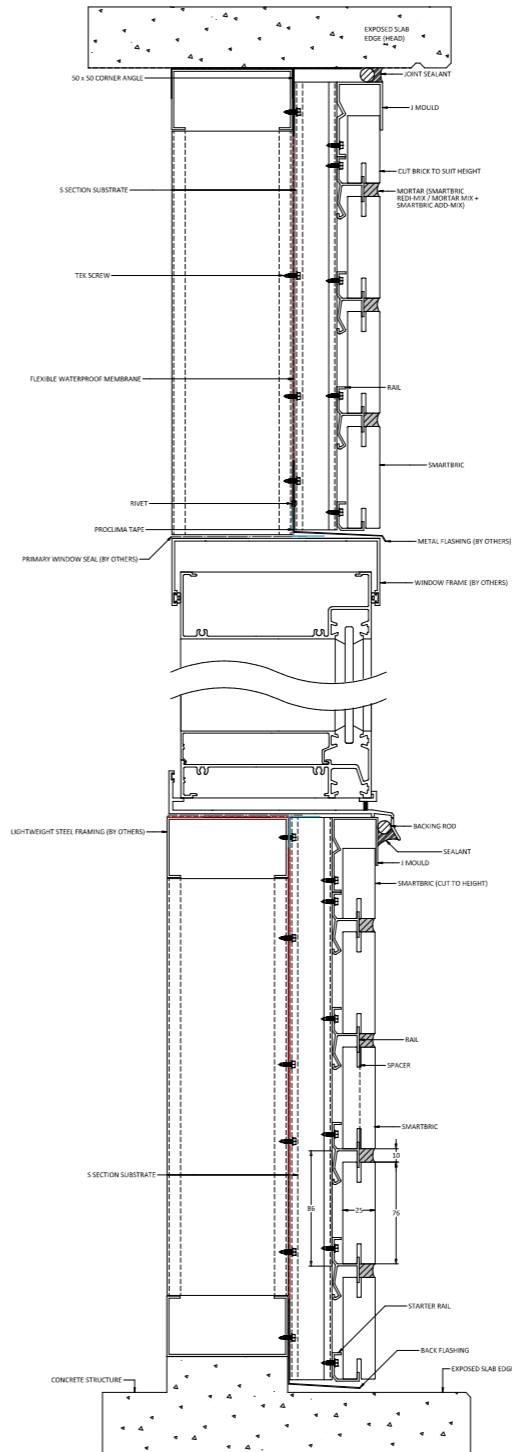

COMPLETE WALL SYSTEM
SMARTBRIC CLASSIC AND TRACK

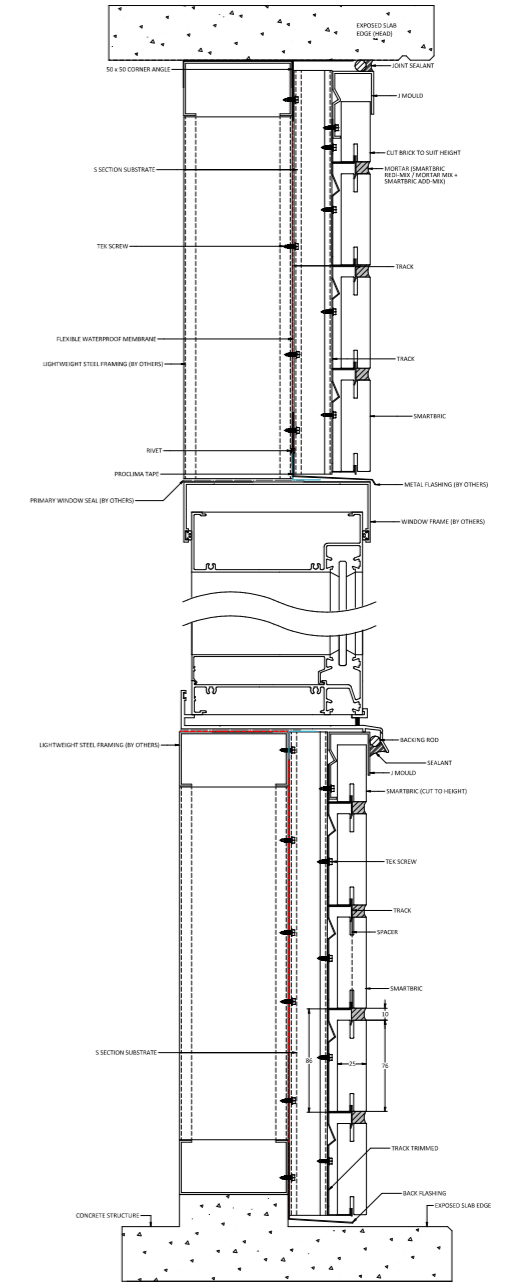

SMARTBRIC - SPECIFICATION DRAWINGS

Smartbric Classic – Facing and Corners

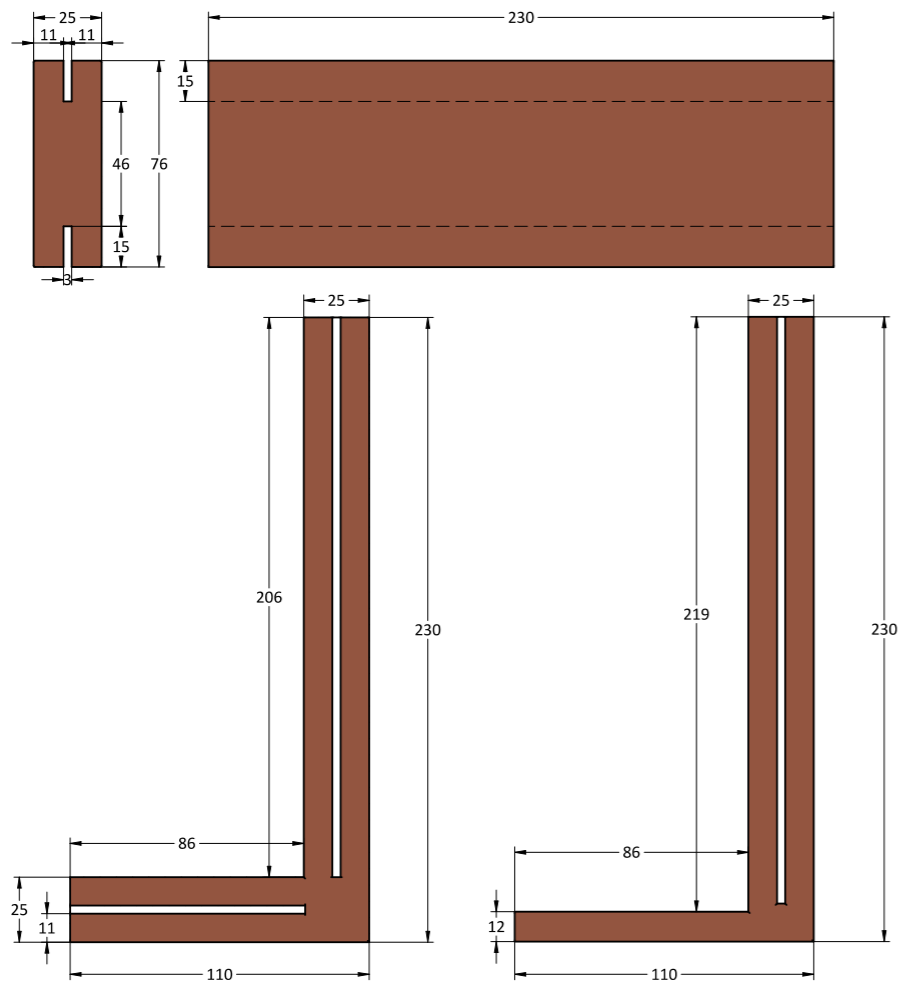

Smartbric Rapid – Facing

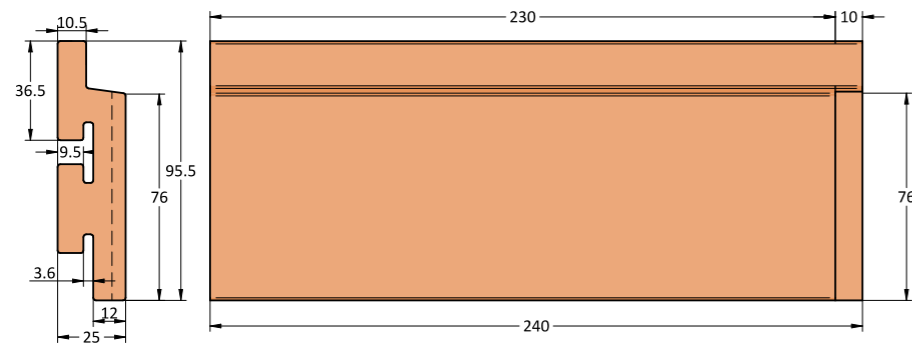

SMARTBRIC RAIL

Standard Rail:

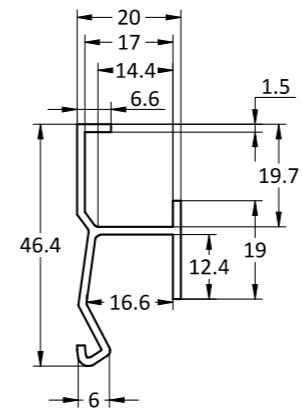

Top Rail:

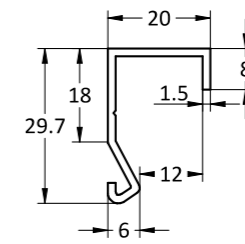

Bottom Rail:

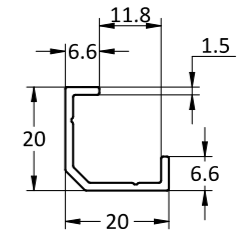

SMARTBRIC TRACK

Standard Track:

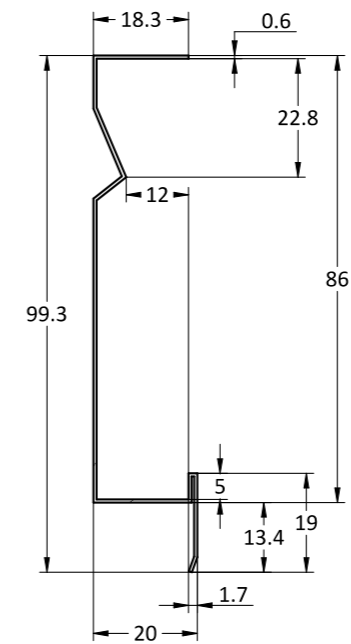

Creeper Track:

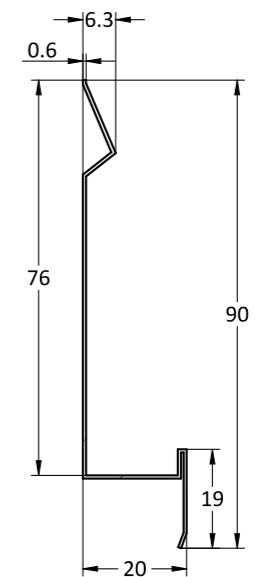

SMARTBRIC RAPID WITH RAIL INSTALLATION

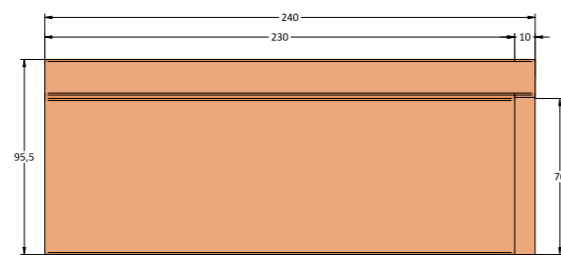
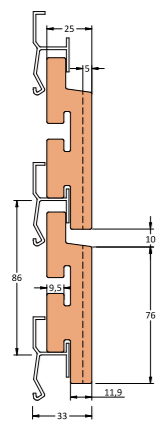
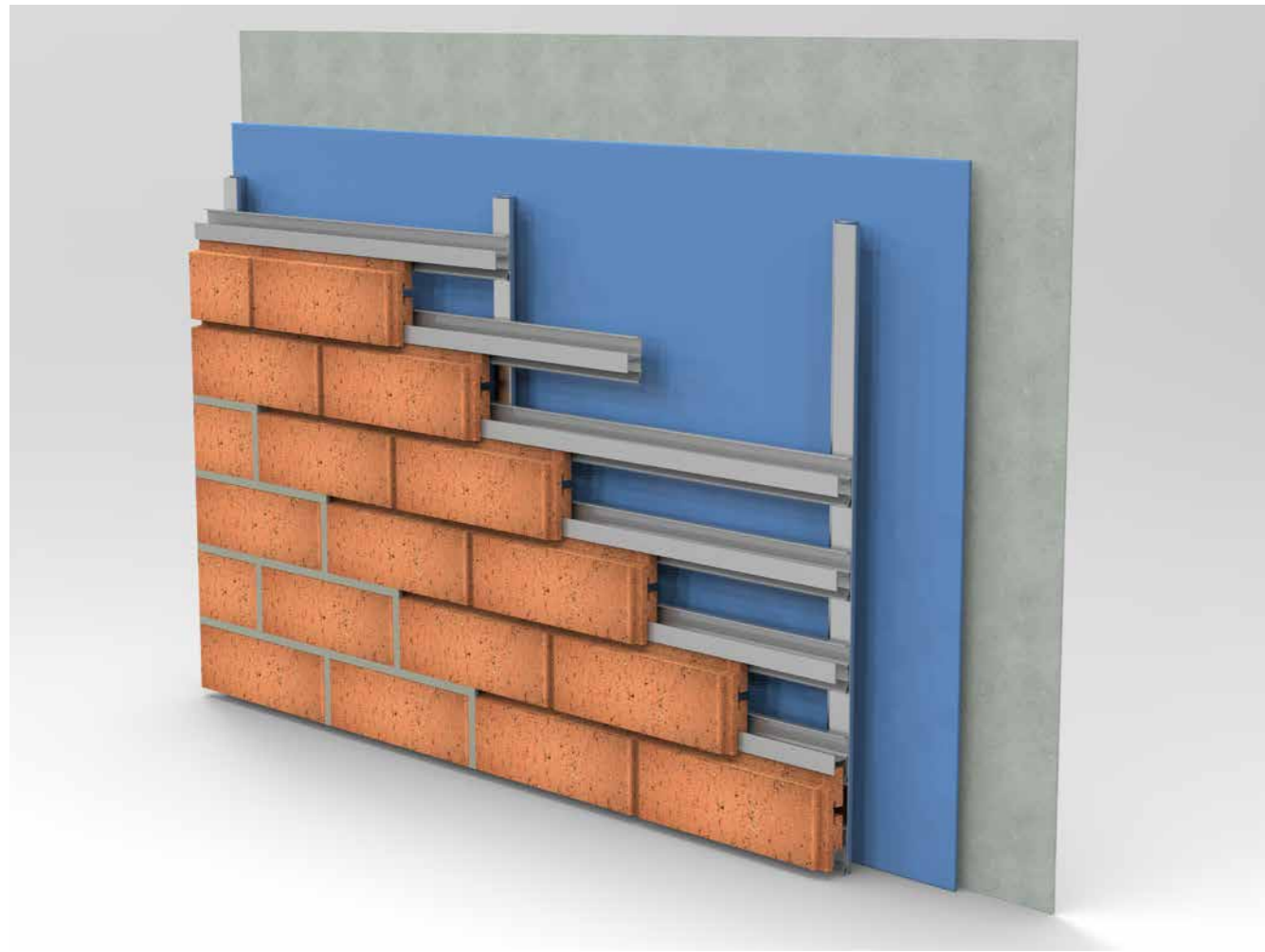

STANDARD RAIL INSTALL

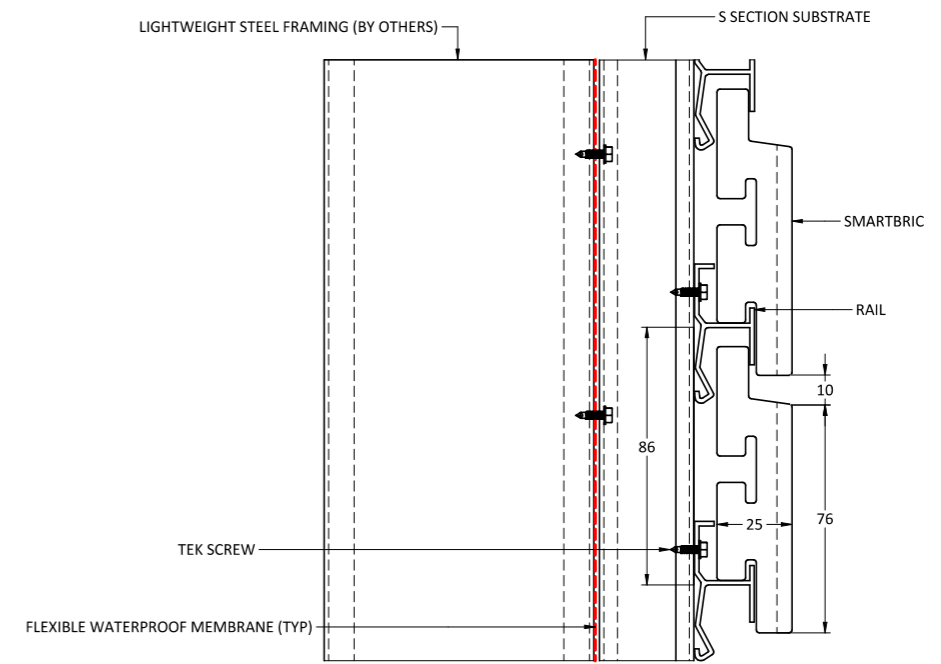

REAR GROOVE INSTALL

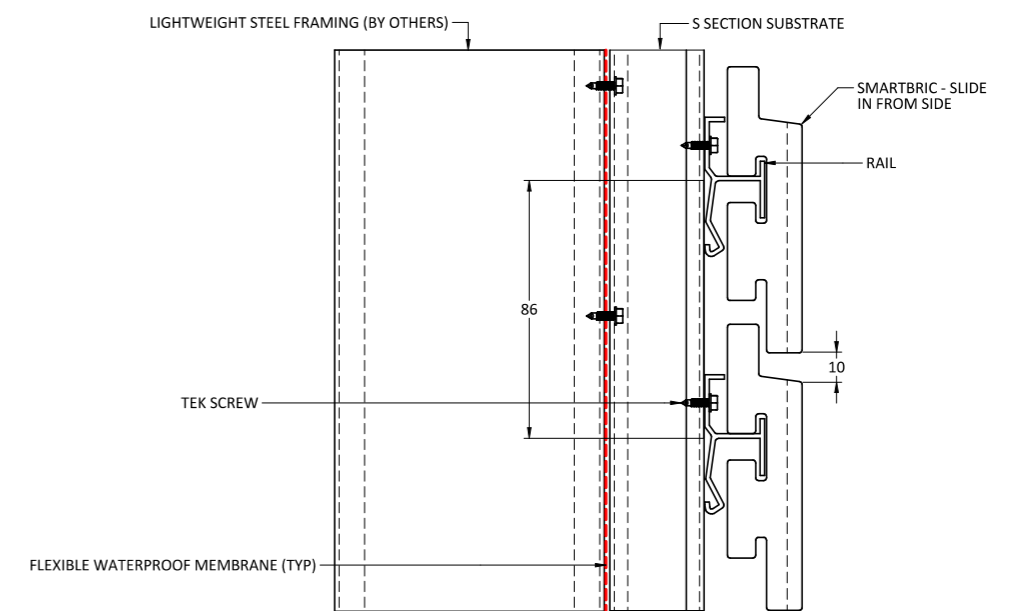

CLOSED GAUGE RAIL INSTALL

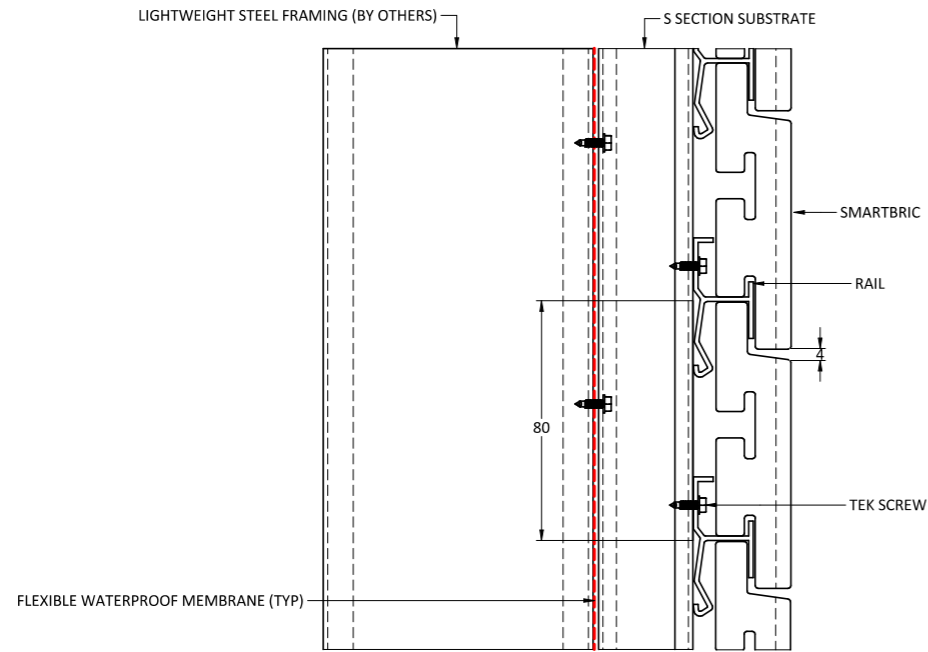

BASE SLAB JUNCTION

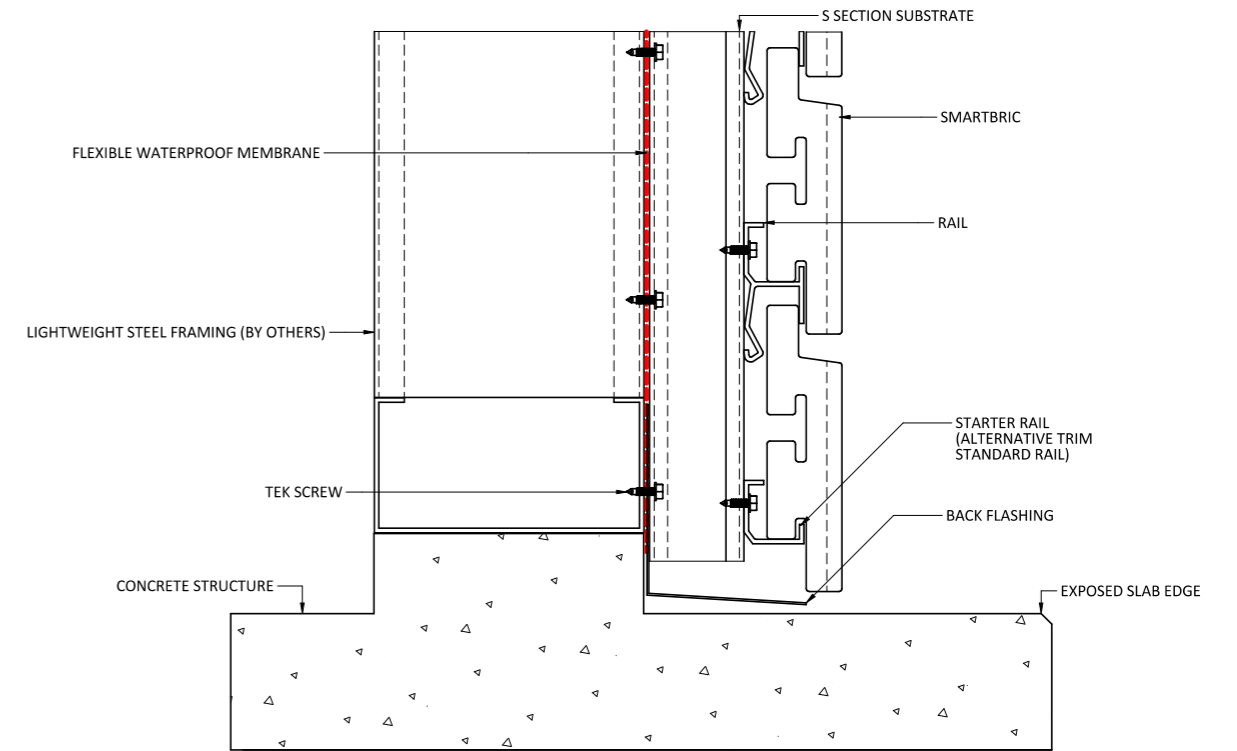

HEAD SLAB JUNCTION

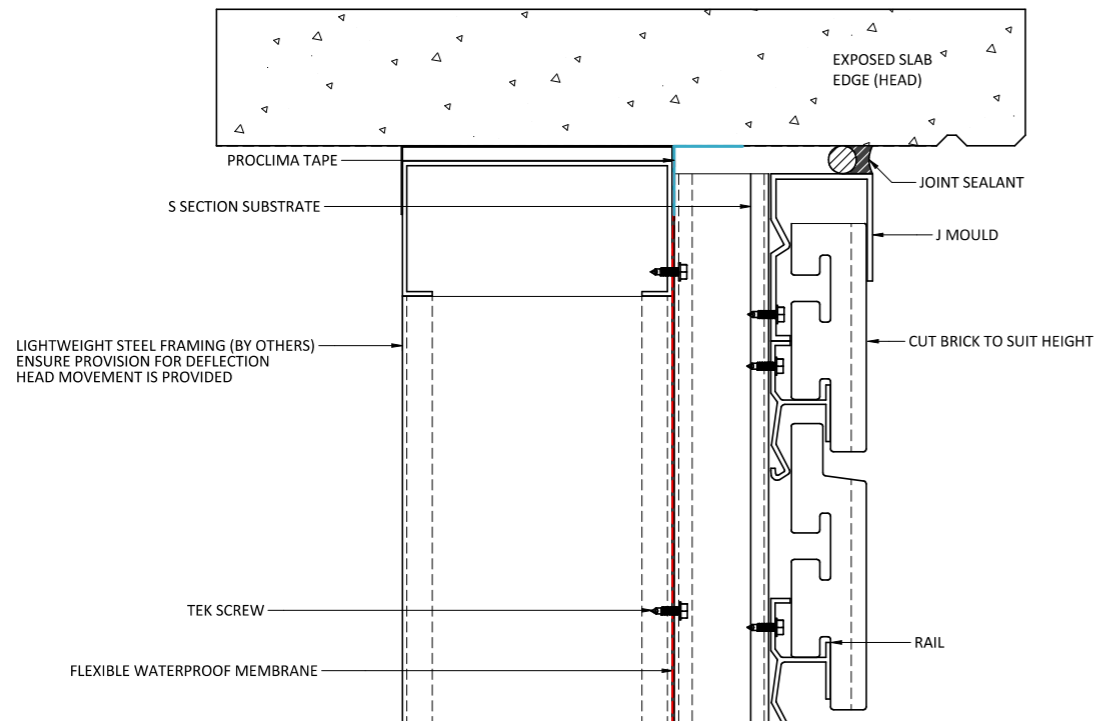

HORIZONTAL EXPANSION JOINT

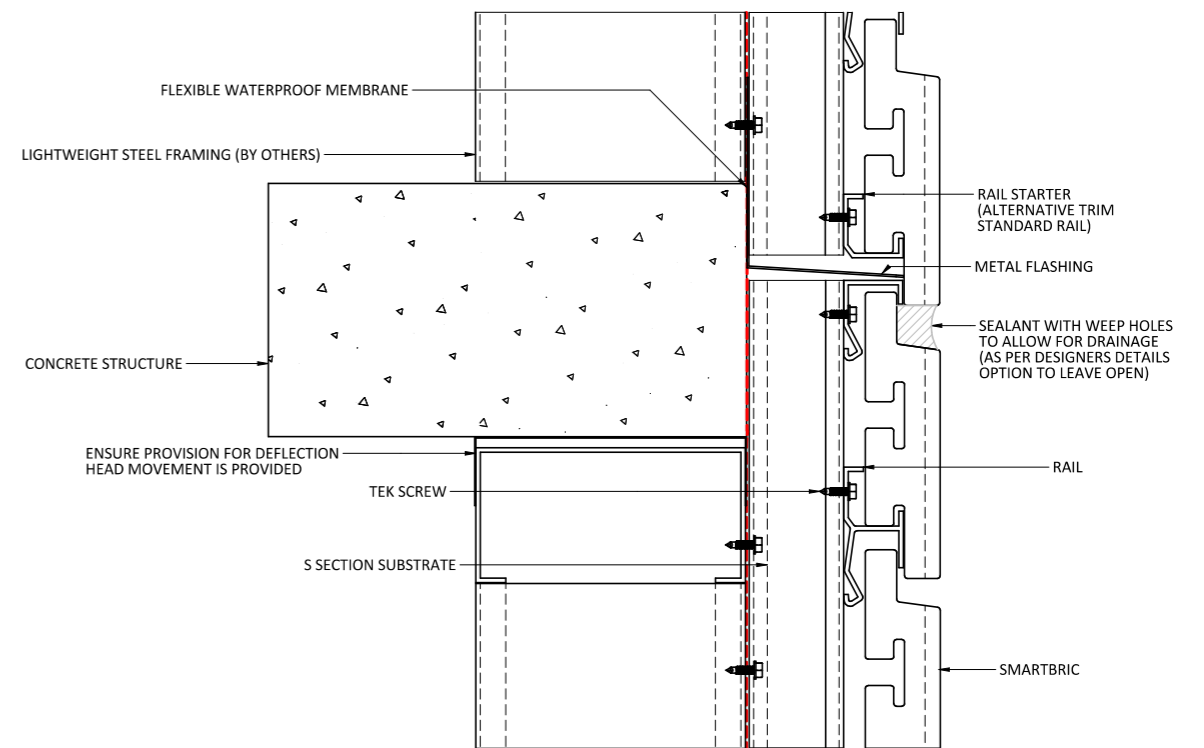

VERTICAL EXPANSION JOINT

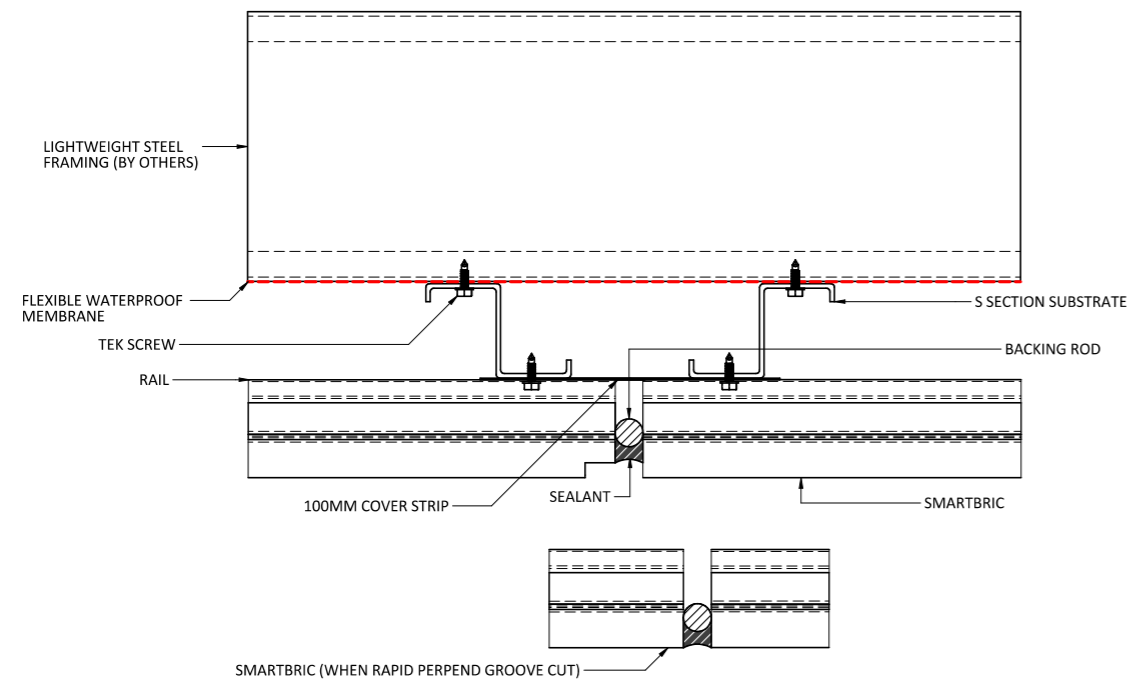

WINDOW SILL DETAIL

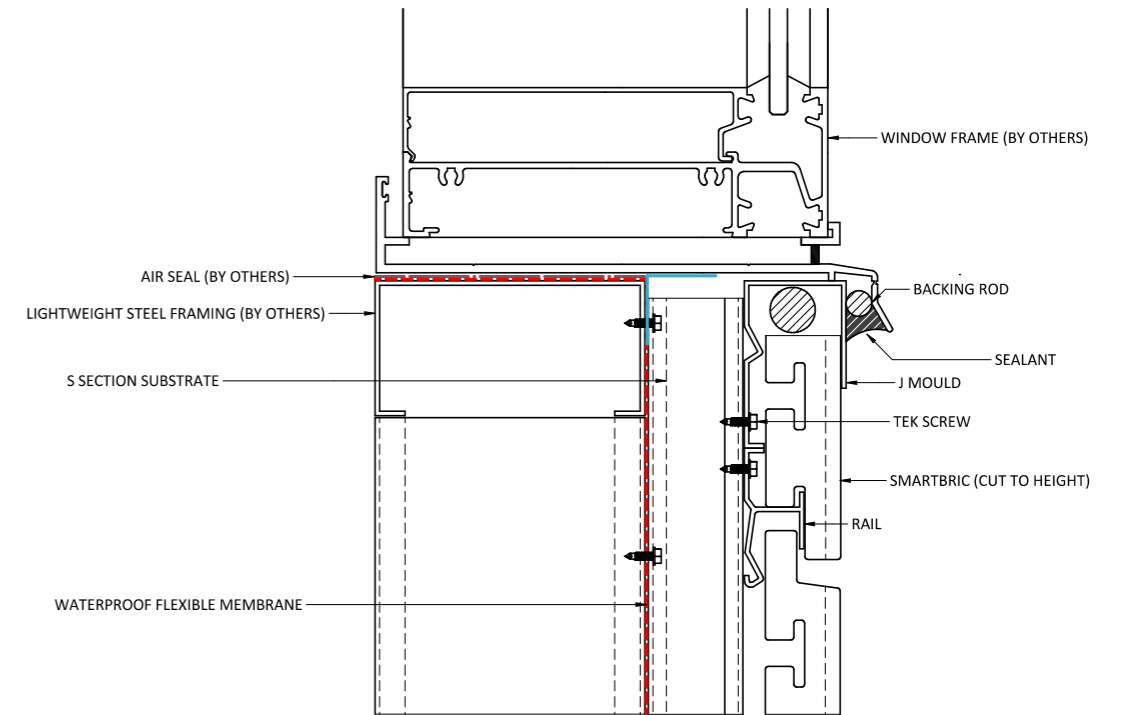

WINDOW HEAD DETAIL

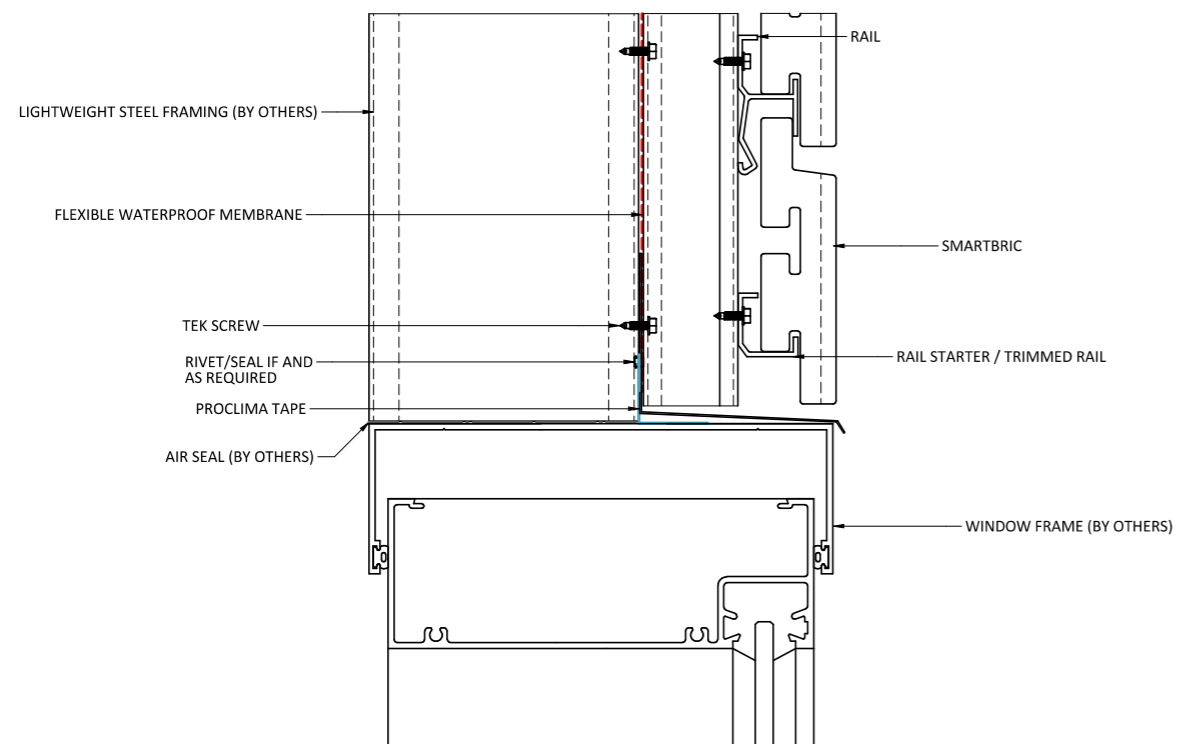

WINDOW JAMB DETAIL

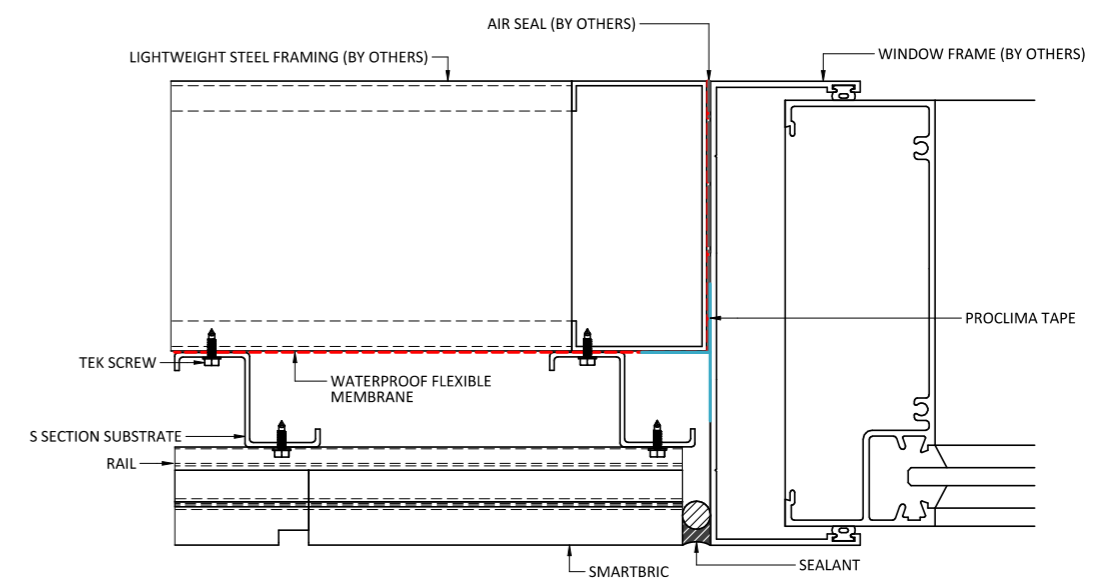

DOOR JAMB DETAIL

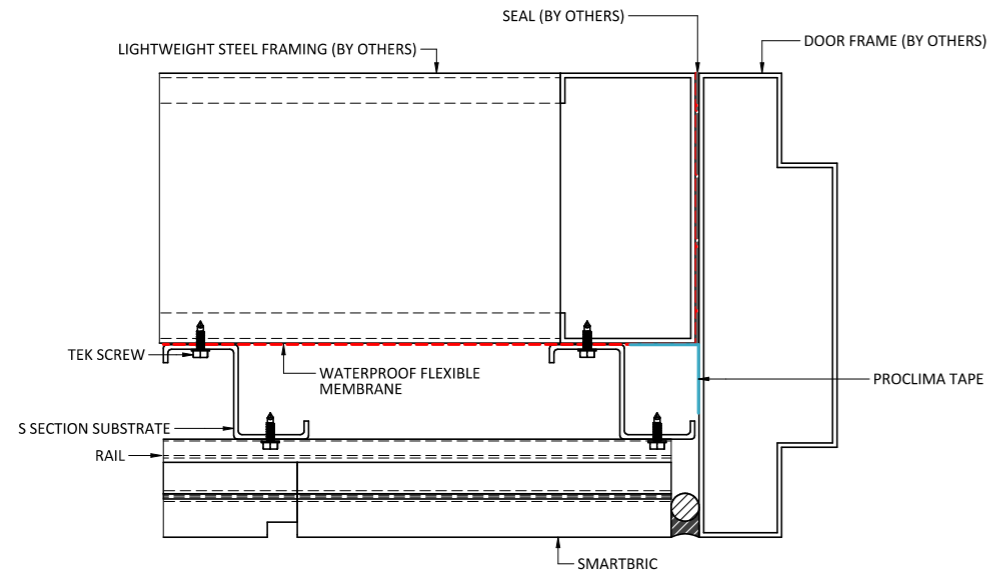

EXTERNAL EXTRUSION CORNER

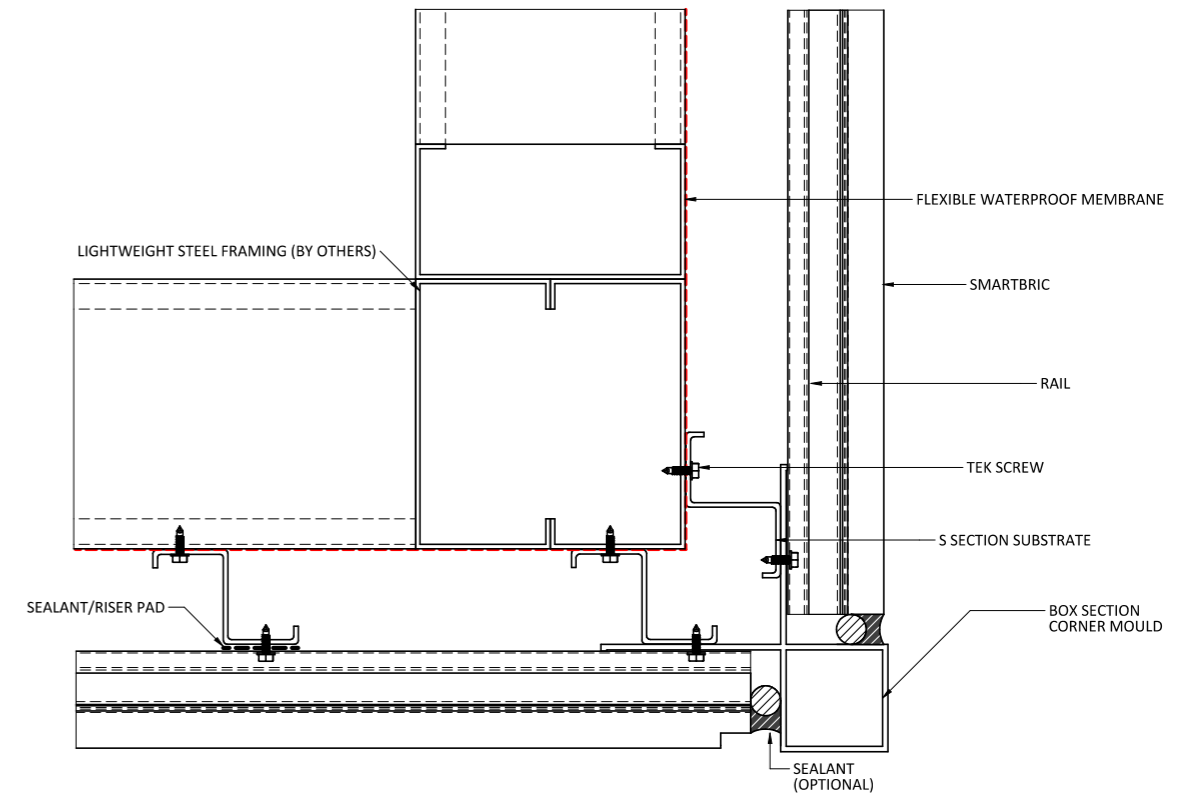

EXTERNAL MITER CORNER

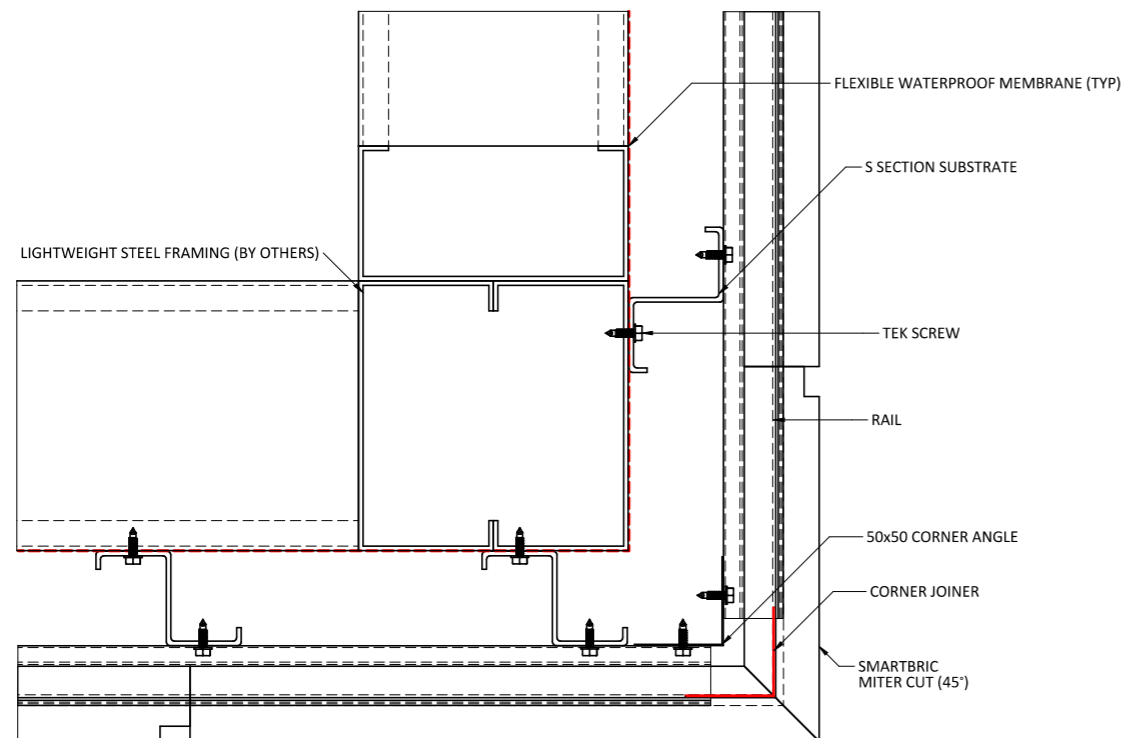

INTERNAL CORNER

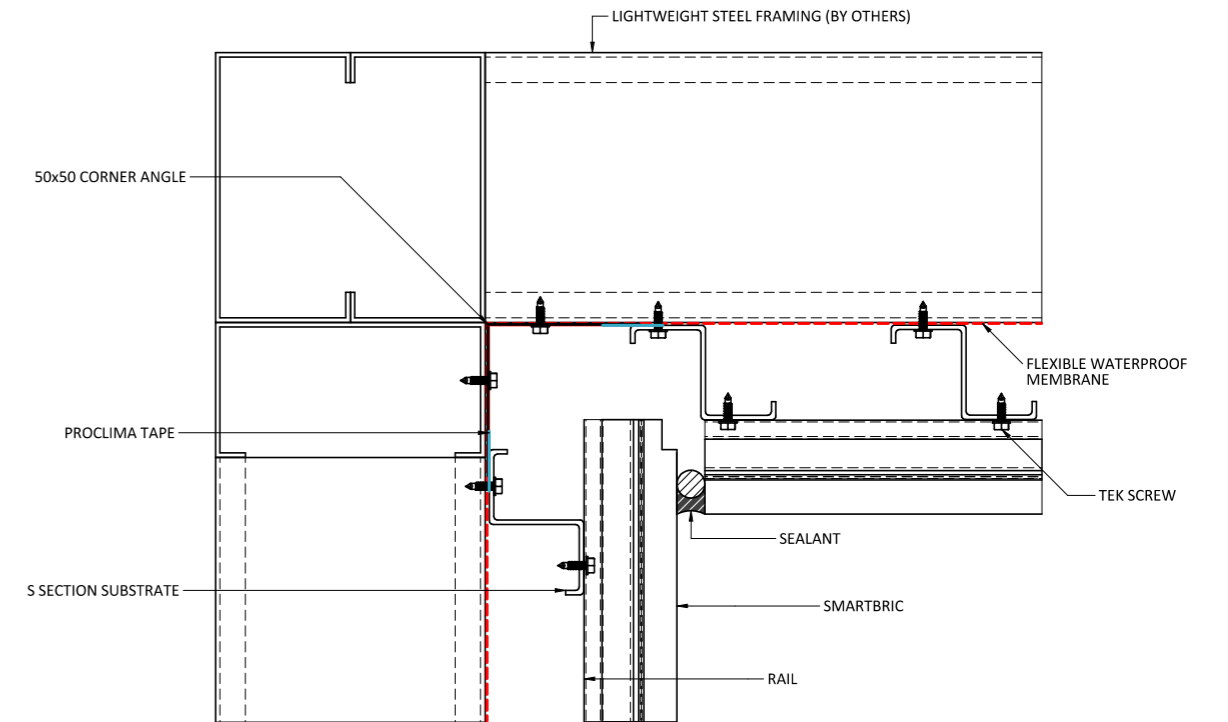

INTERNAL EXTRUSION CORNER

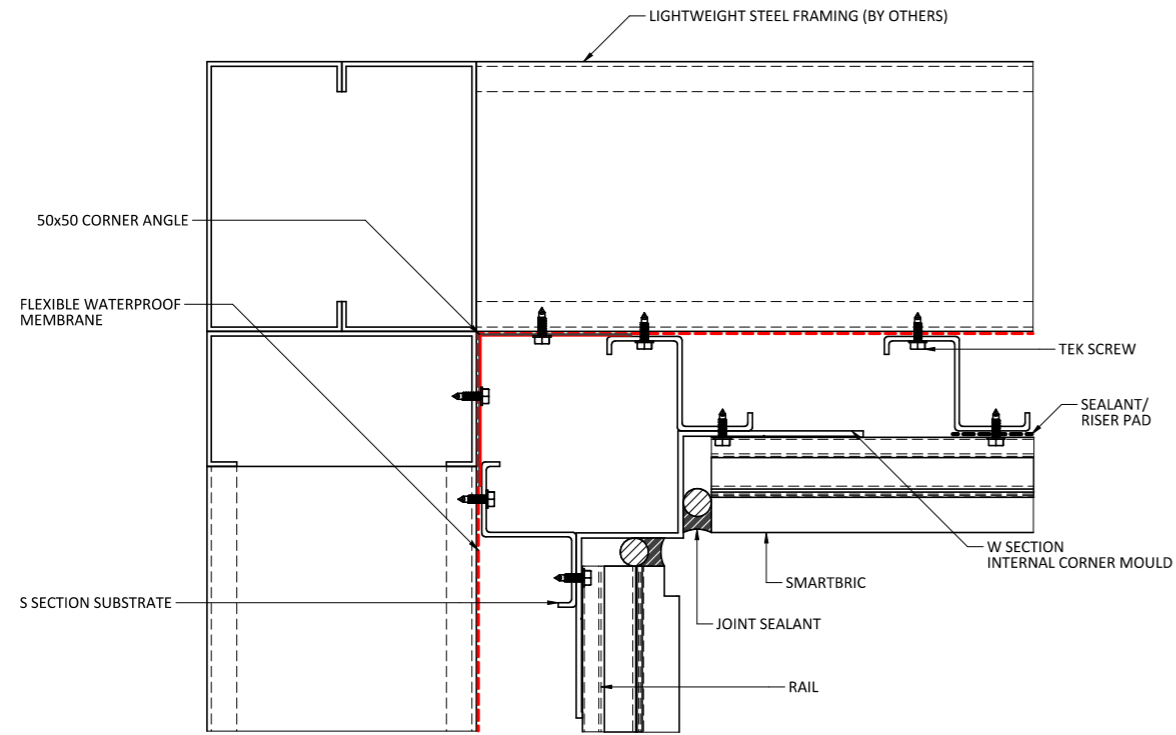

SOFFIT EXTERNAL

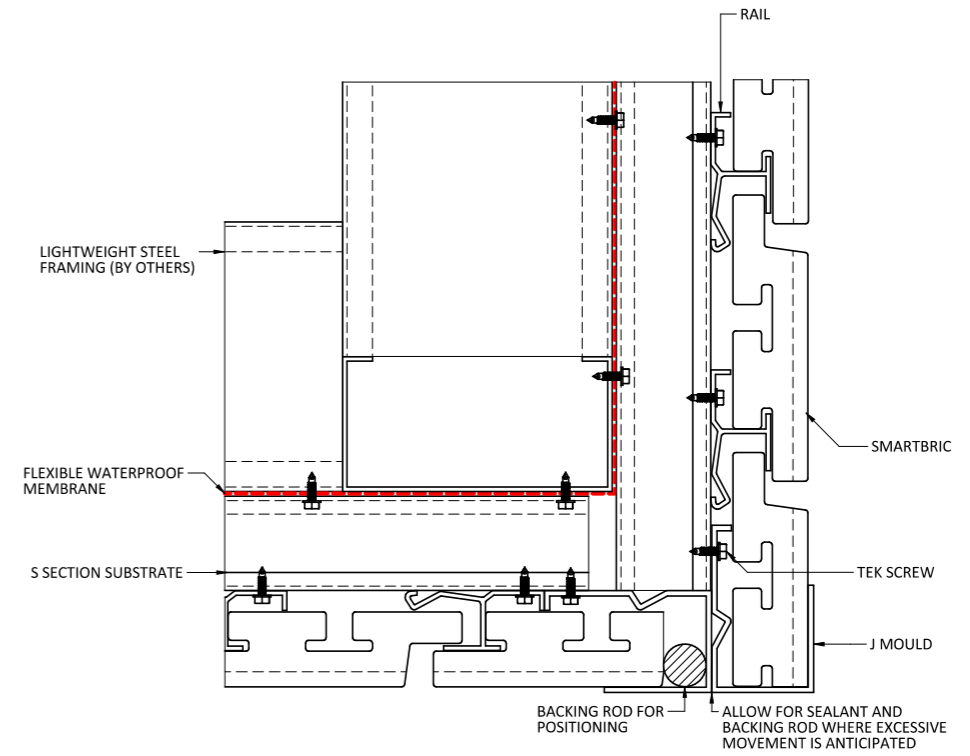

SOFFIT INTERNAL

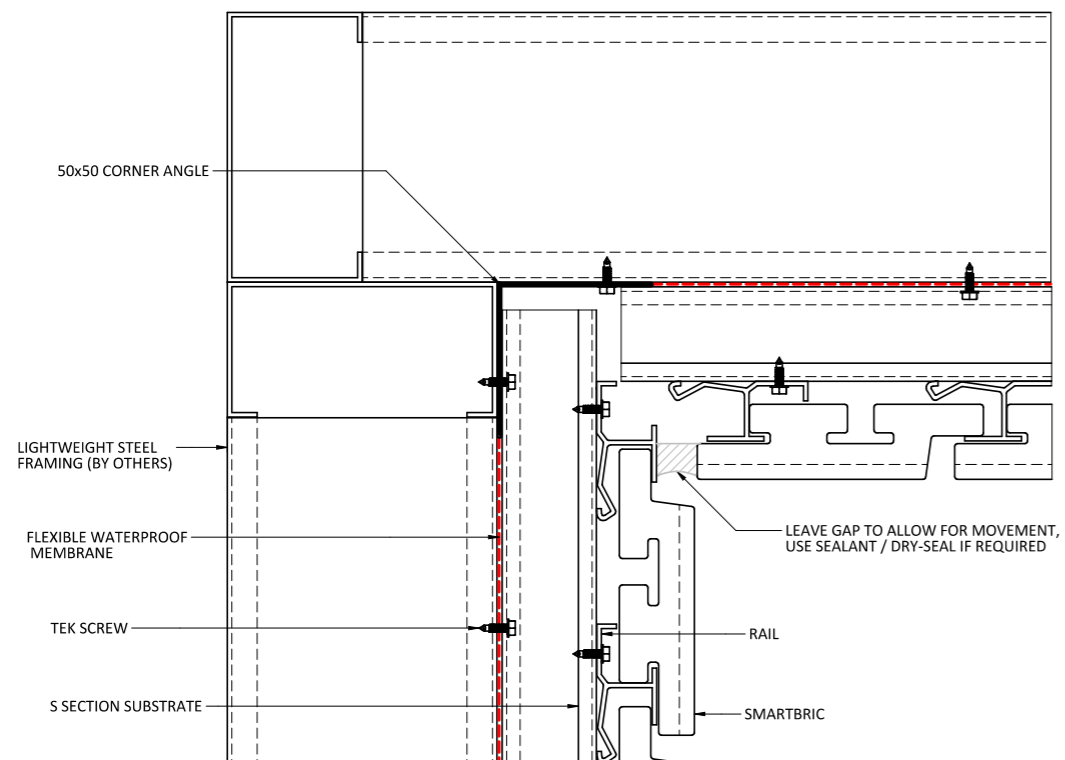

PARAPET DETAIL

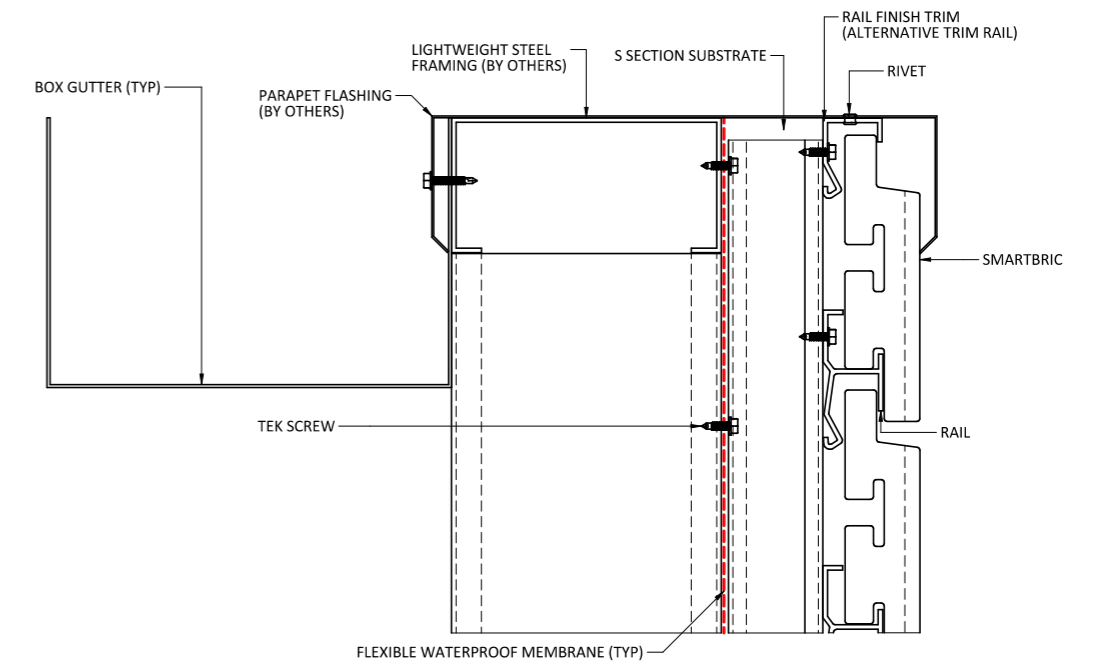

SMARTBRIC RAPID WITH TRACK INSTALLATION

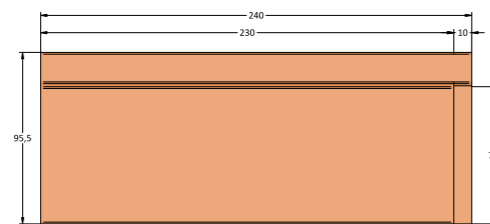
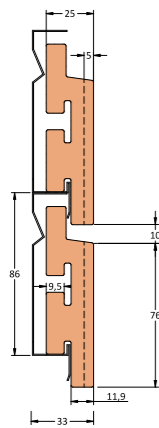
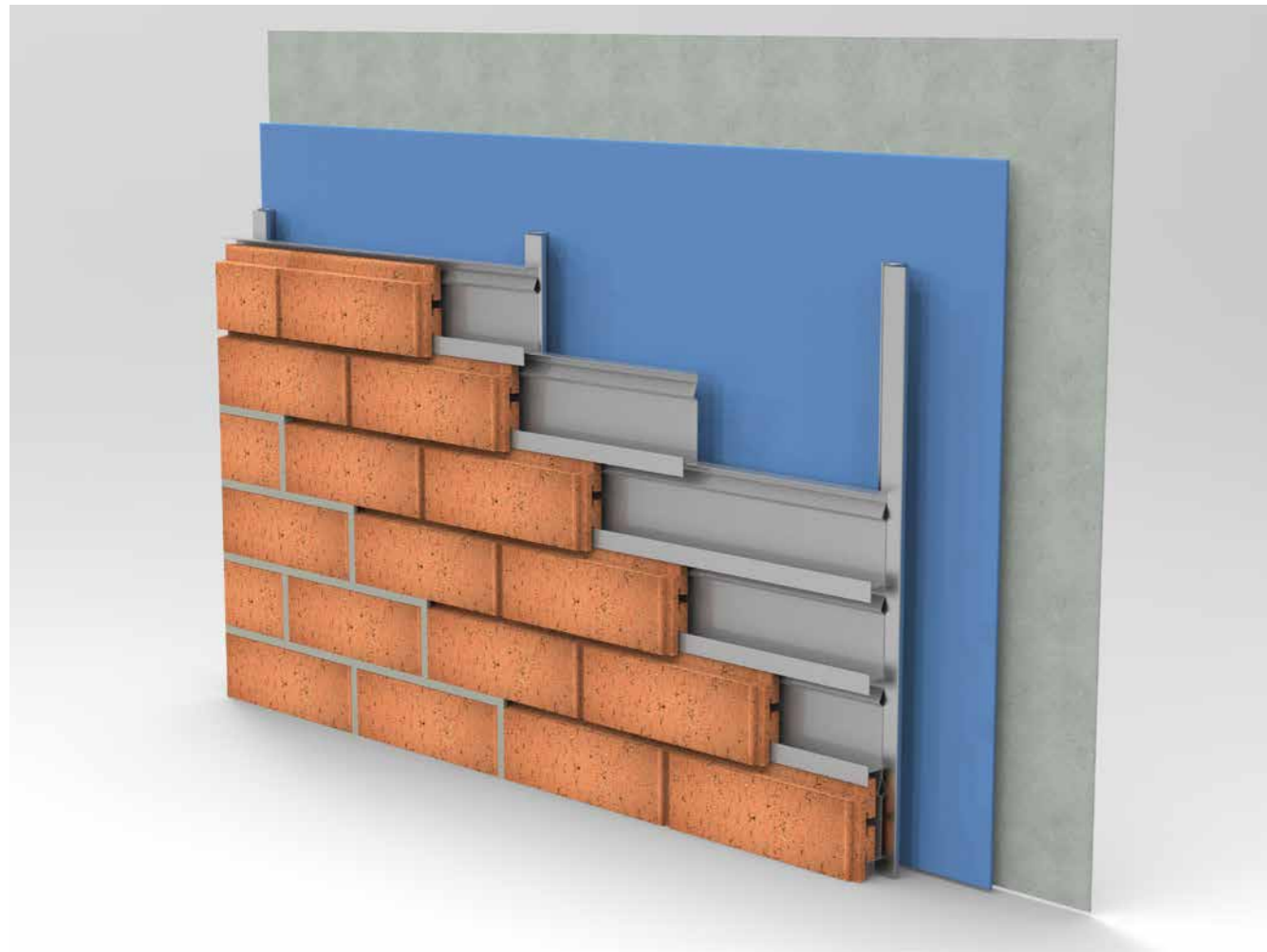

STANDARD TRACK INSTALL

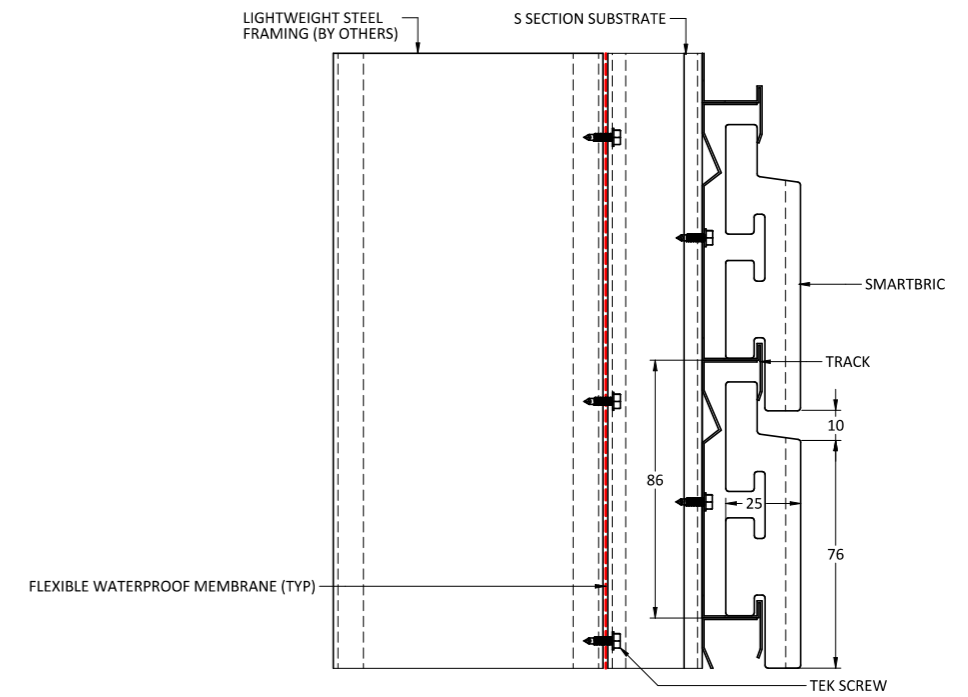

HEAD SLAB JUNCTION

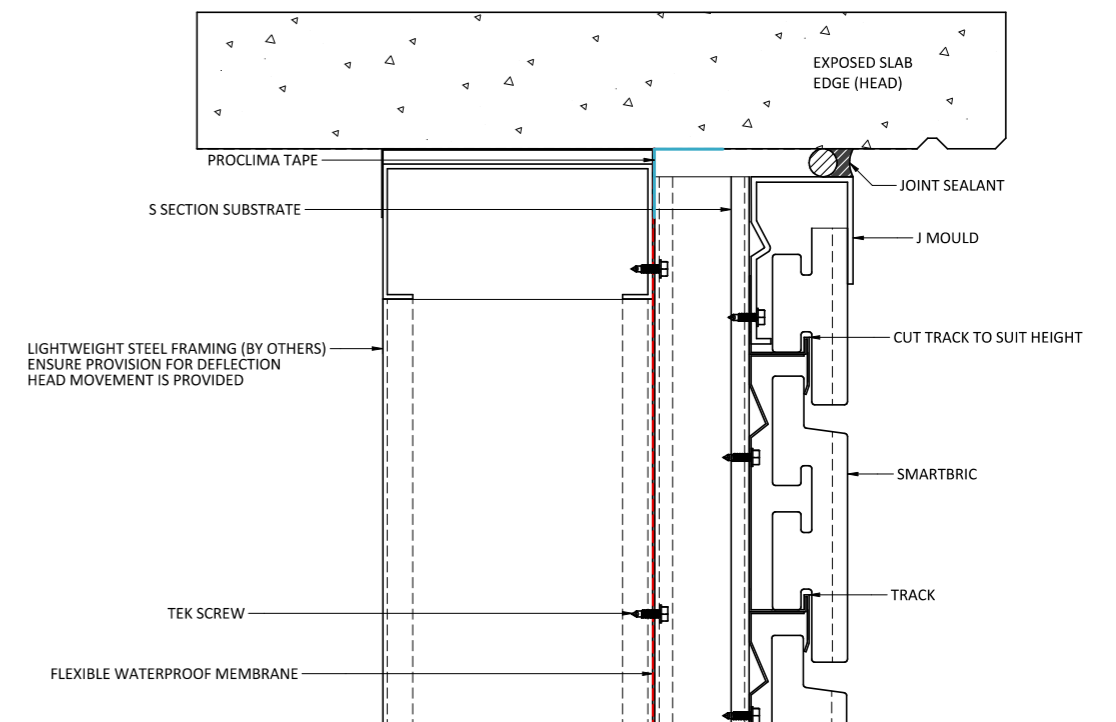

BASE SLAB JUNCTION

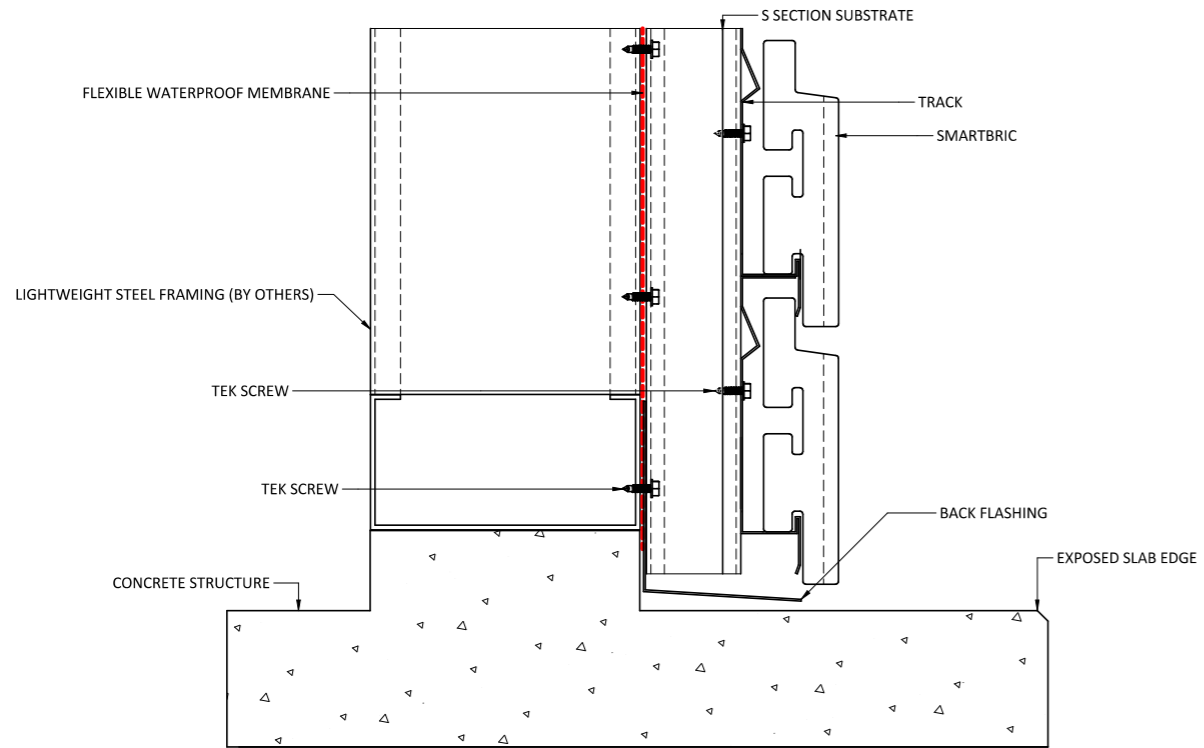

VERTICAL EXPANSION JOINT

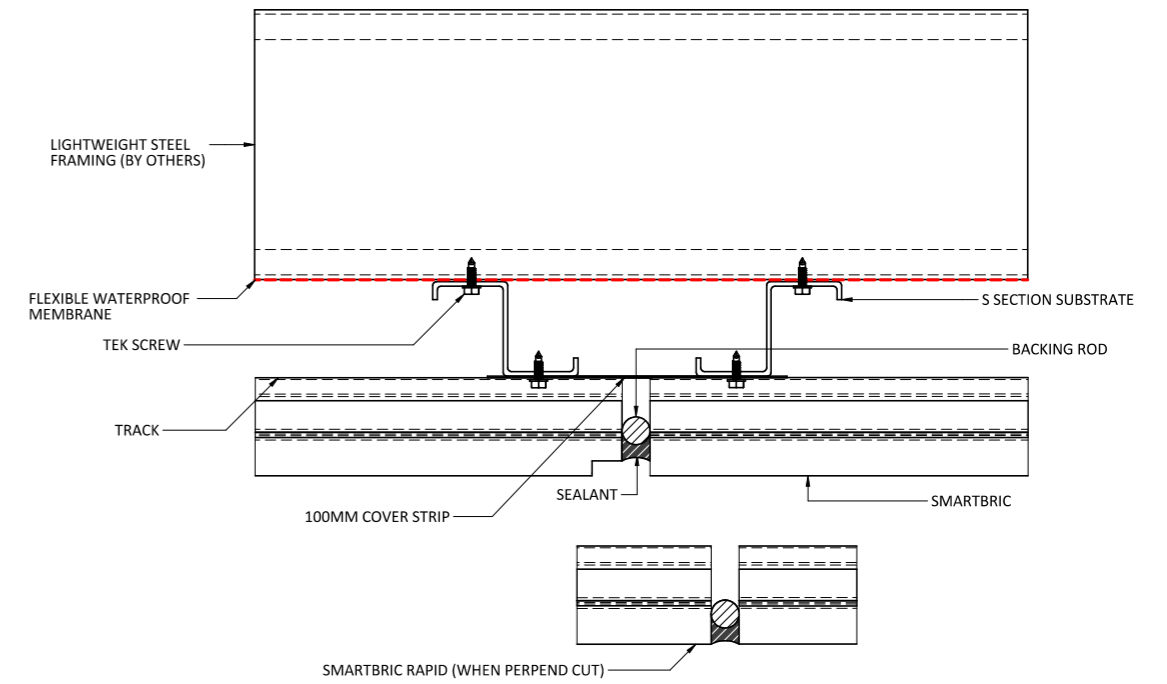

HORIZONTAL EXPANSION JOINT

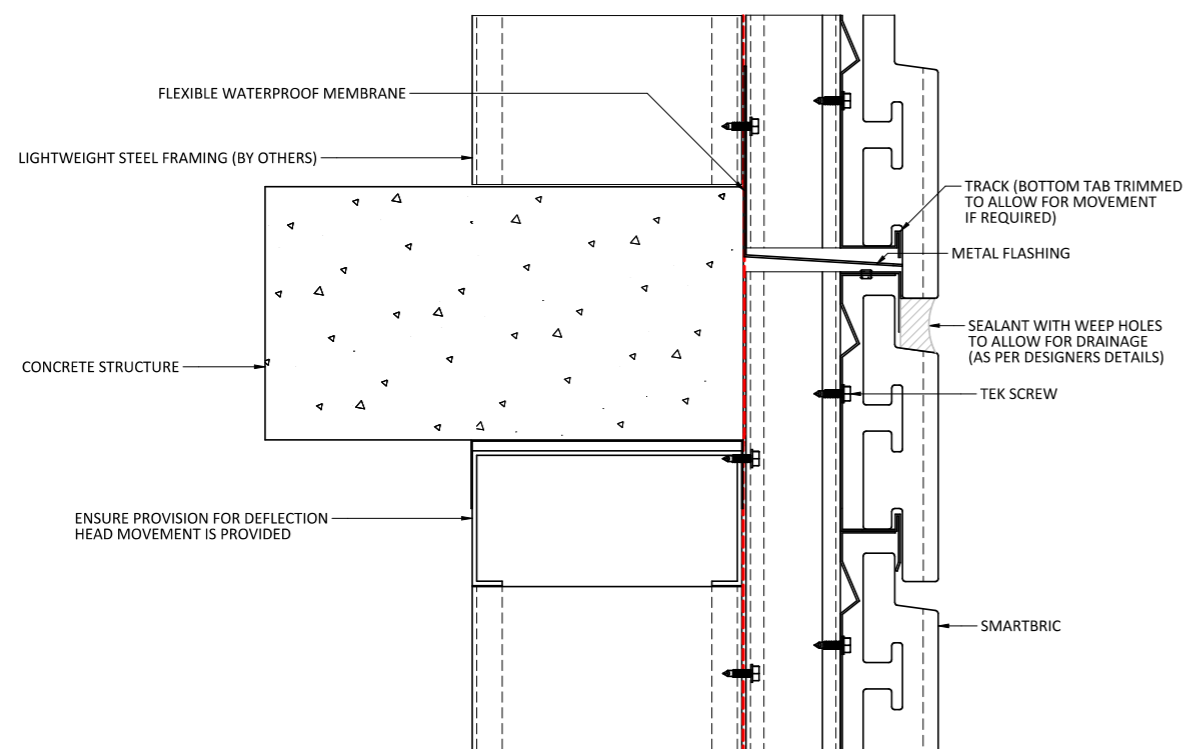

WINDOW HEAD DETAIL

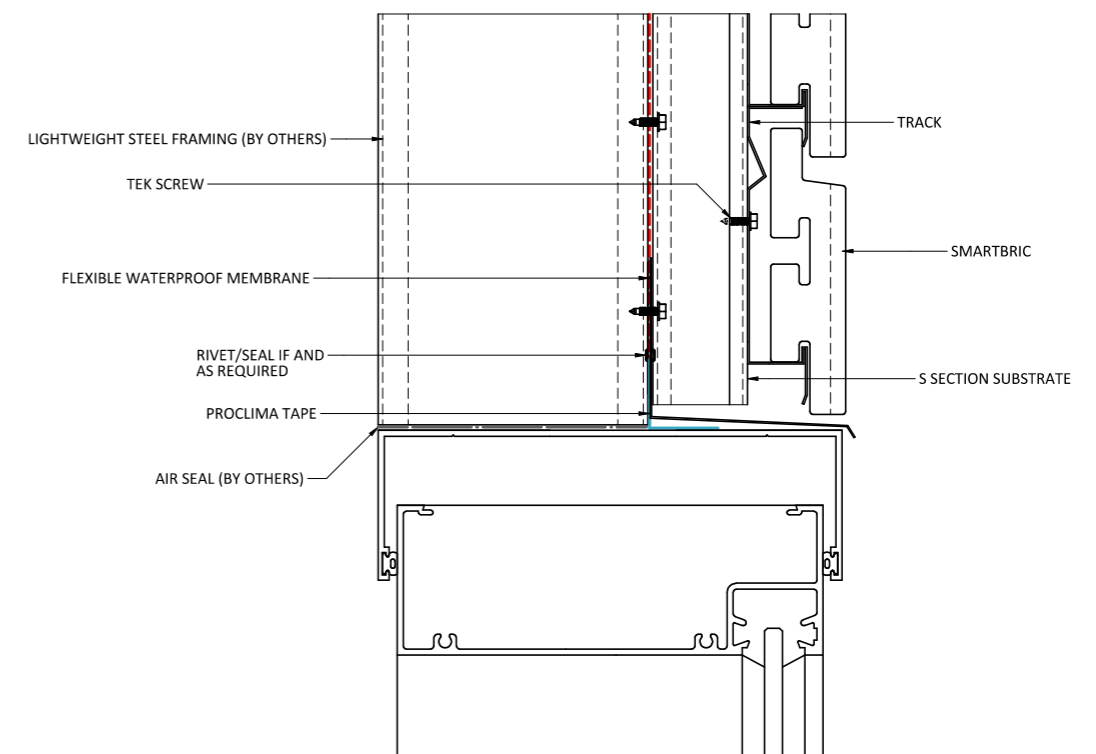

WINDOW SILL DETAIL

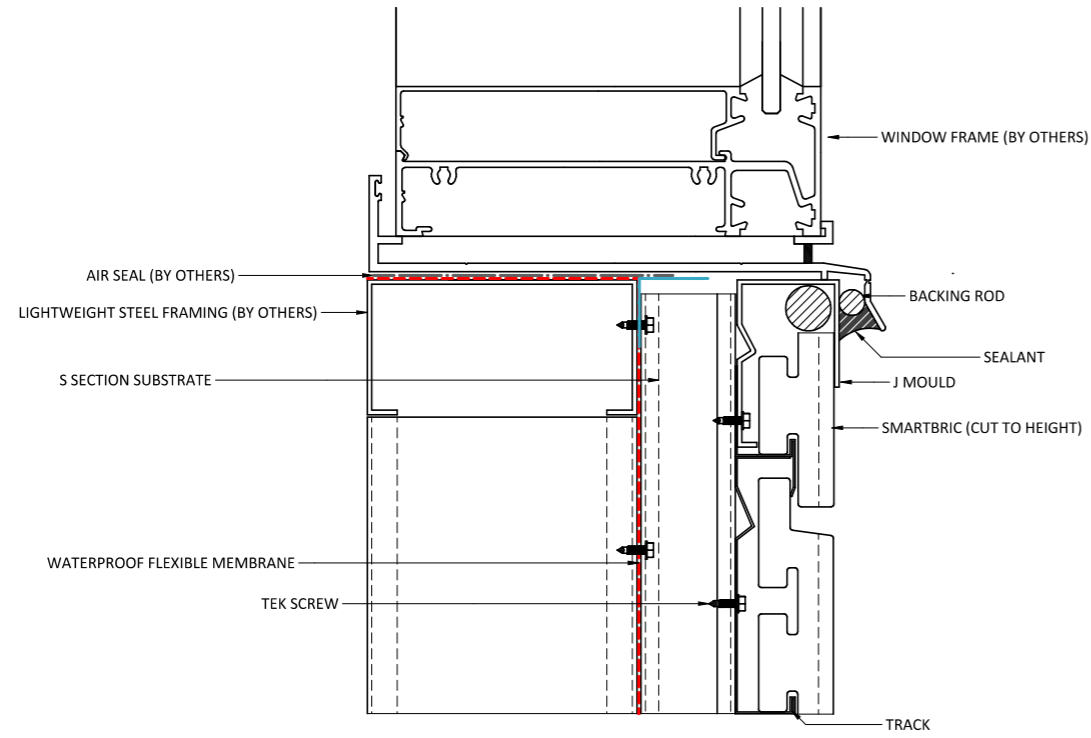

DOOR JAMB DETAIL

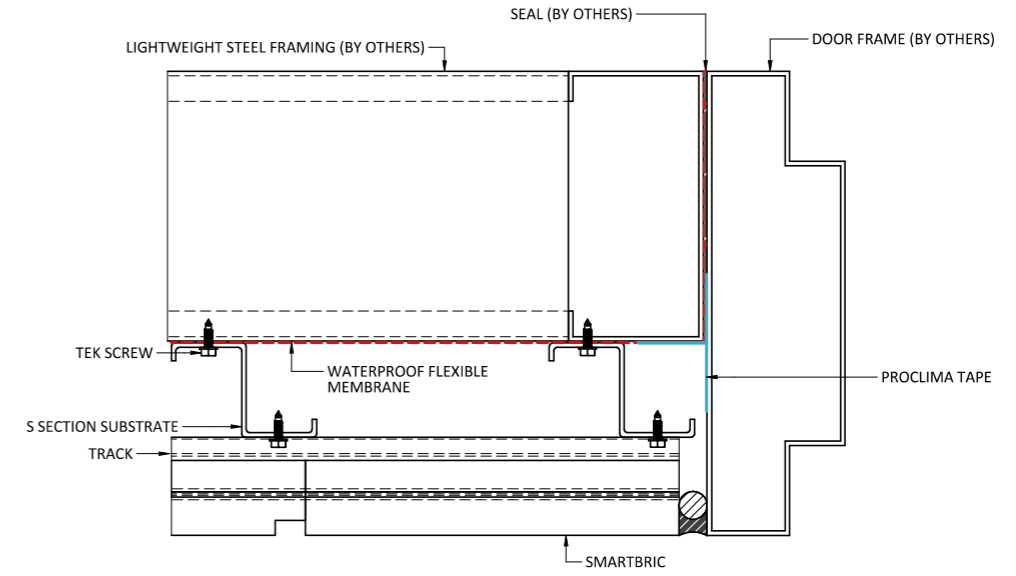

WINDOW JAMB DETAIL

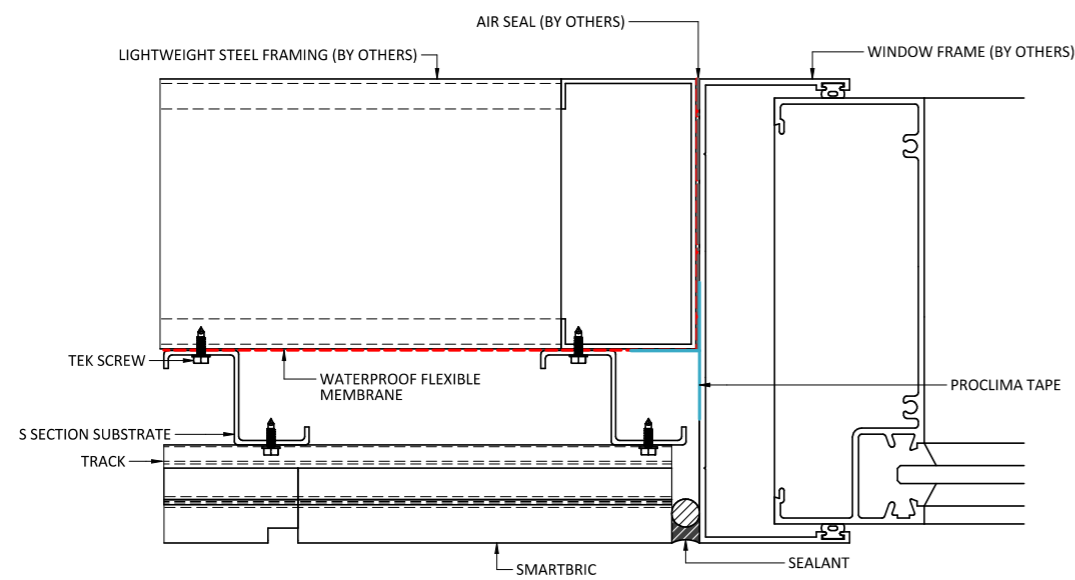

EXTERNAL MITER CORNER

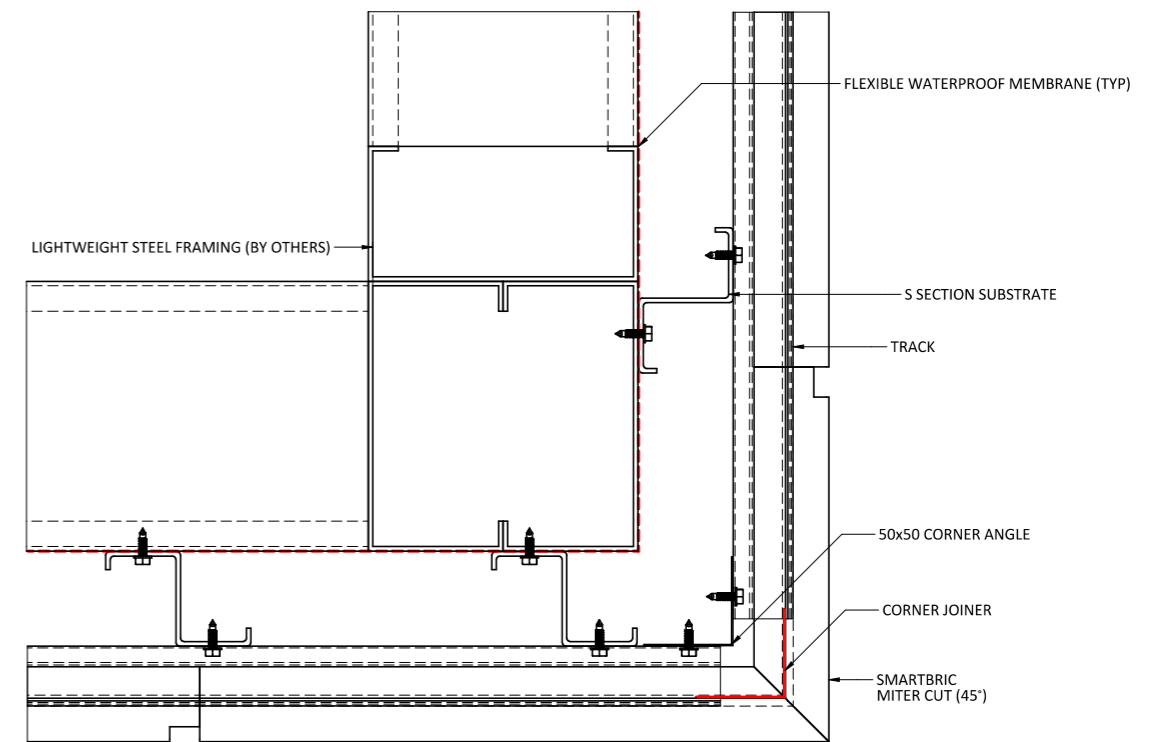

EXTERNAL EXTRUSION CORNER

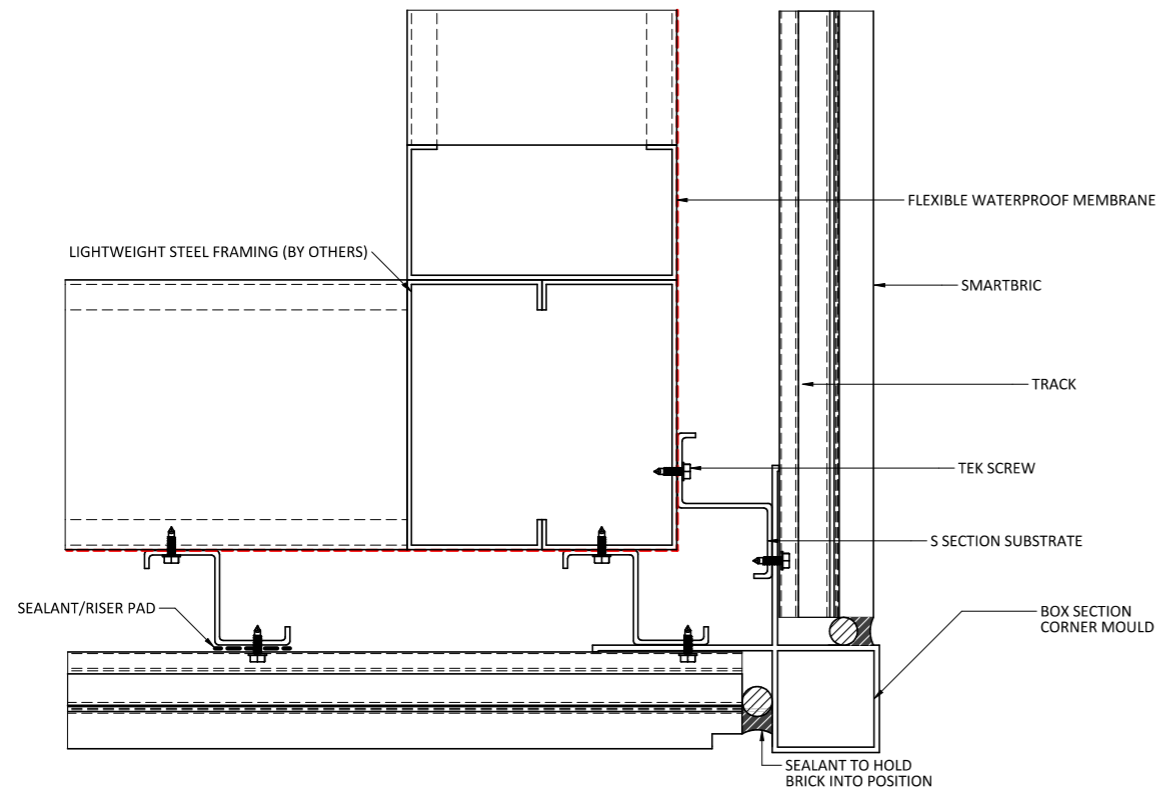

INTERNAL EXTRUSION CORNER

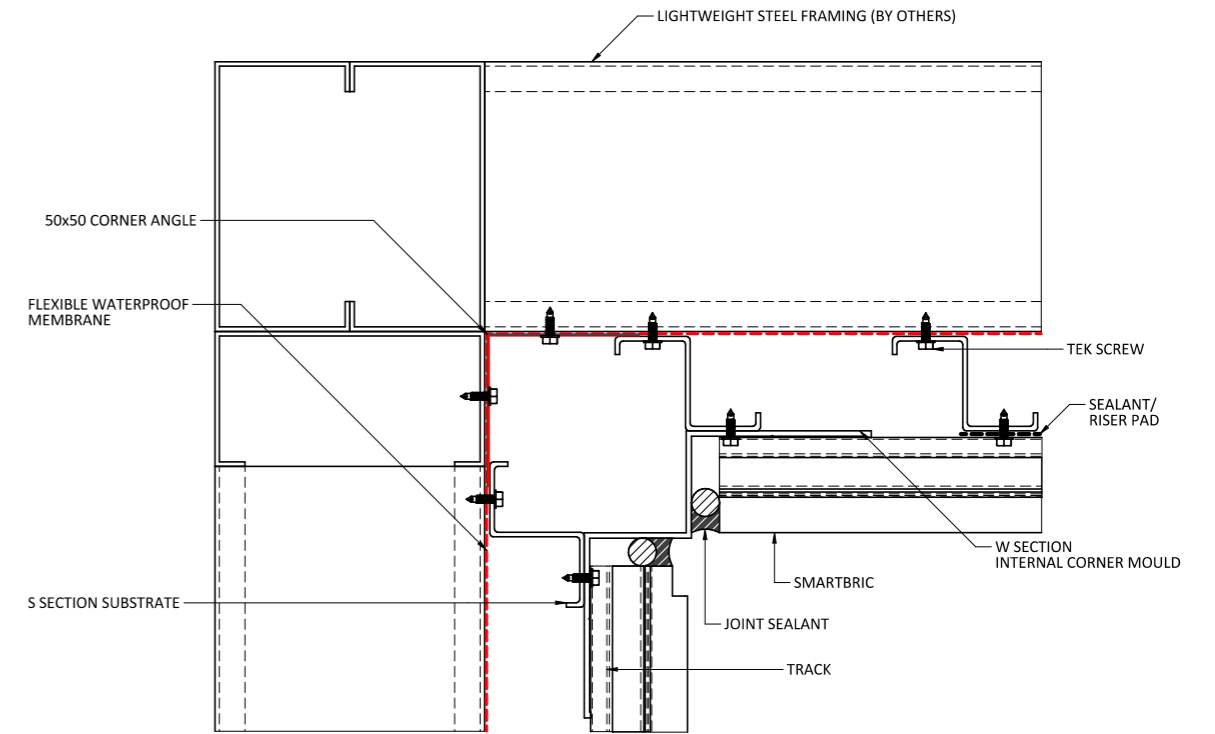

INTERNAL CORNER

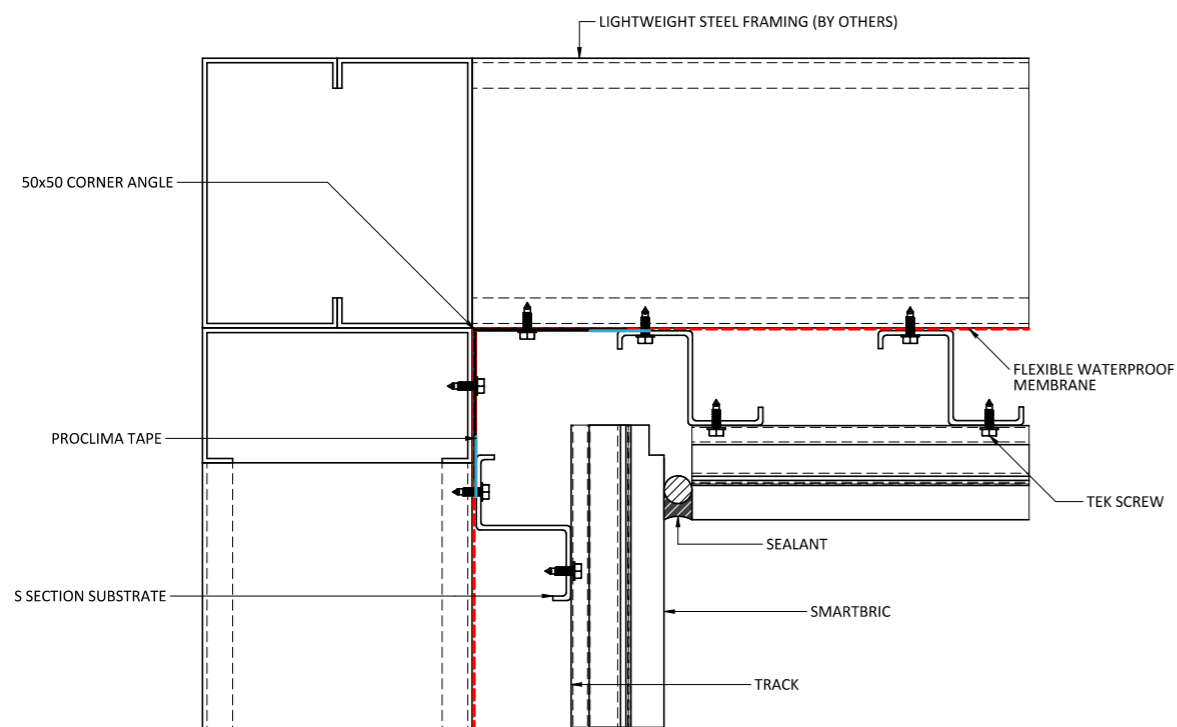

SOFFIT INTERNAL

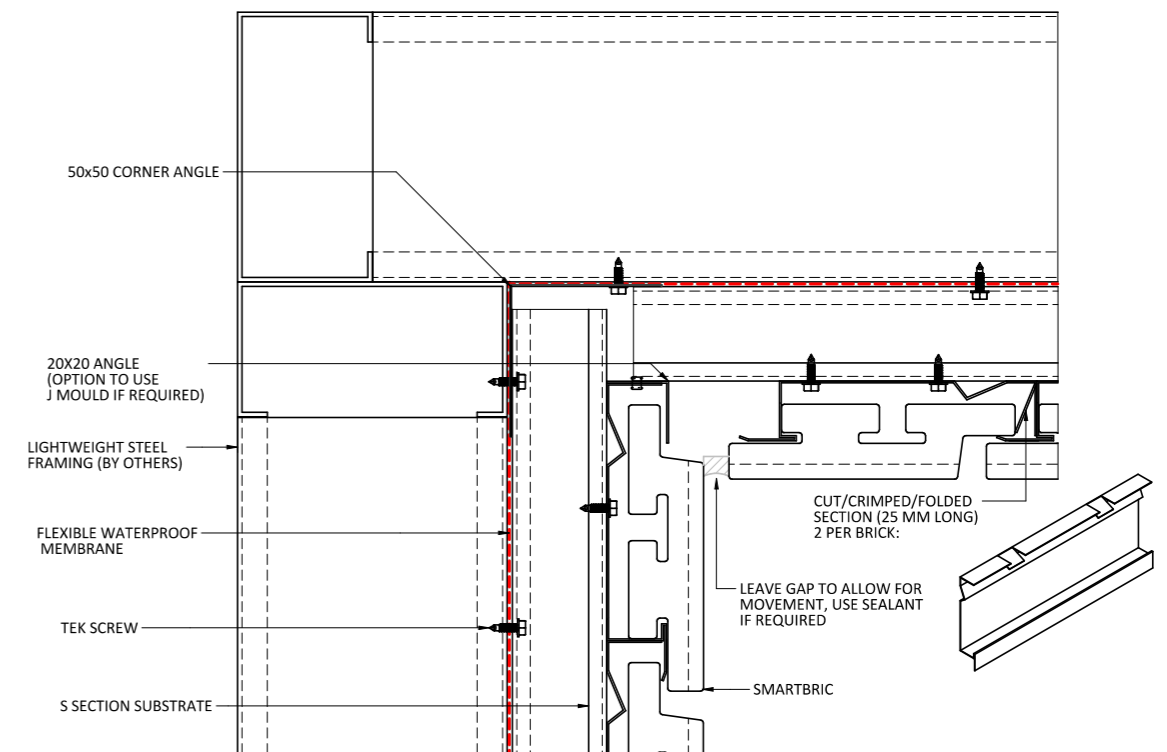

SOFFIT INTERNAL

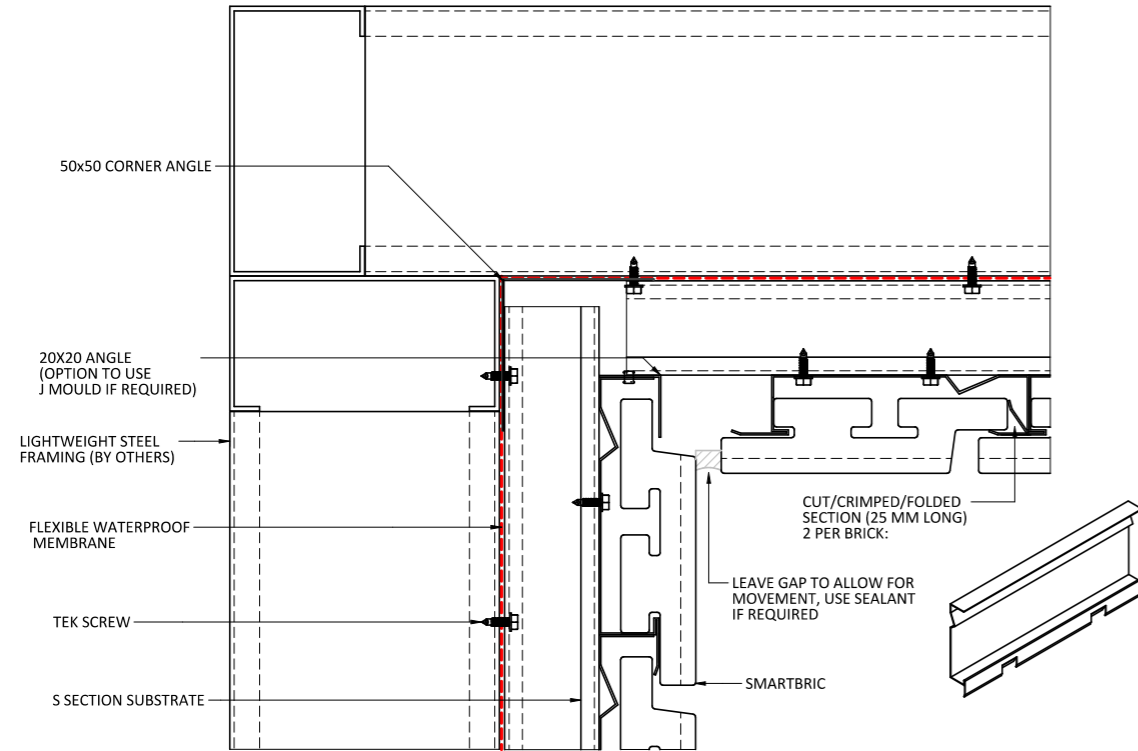

PARAPET

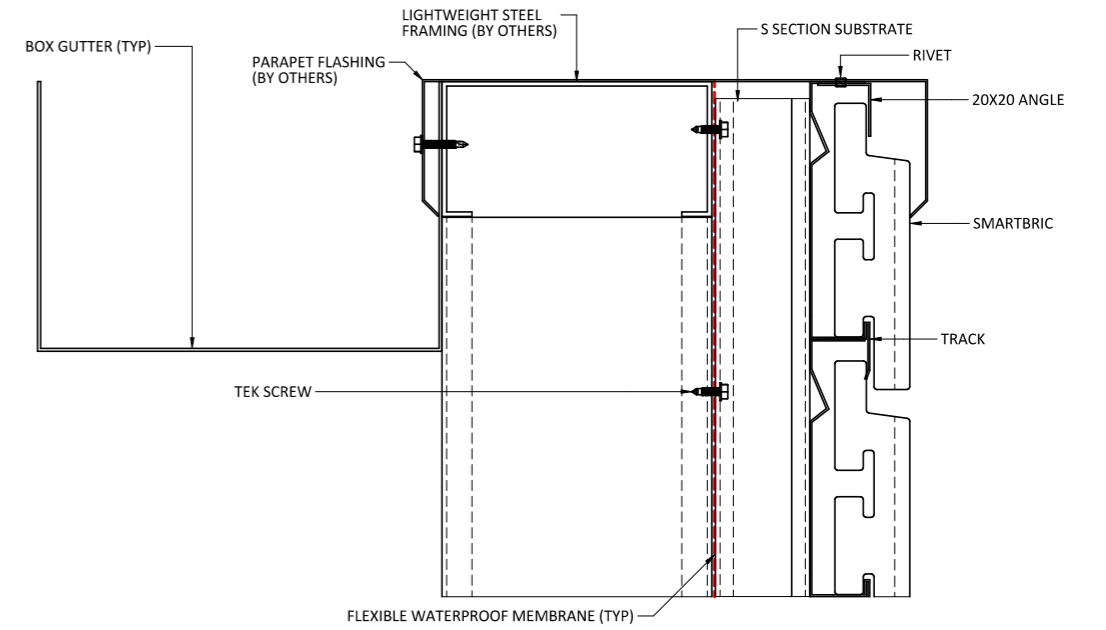

SOFFIT EXTERNAL

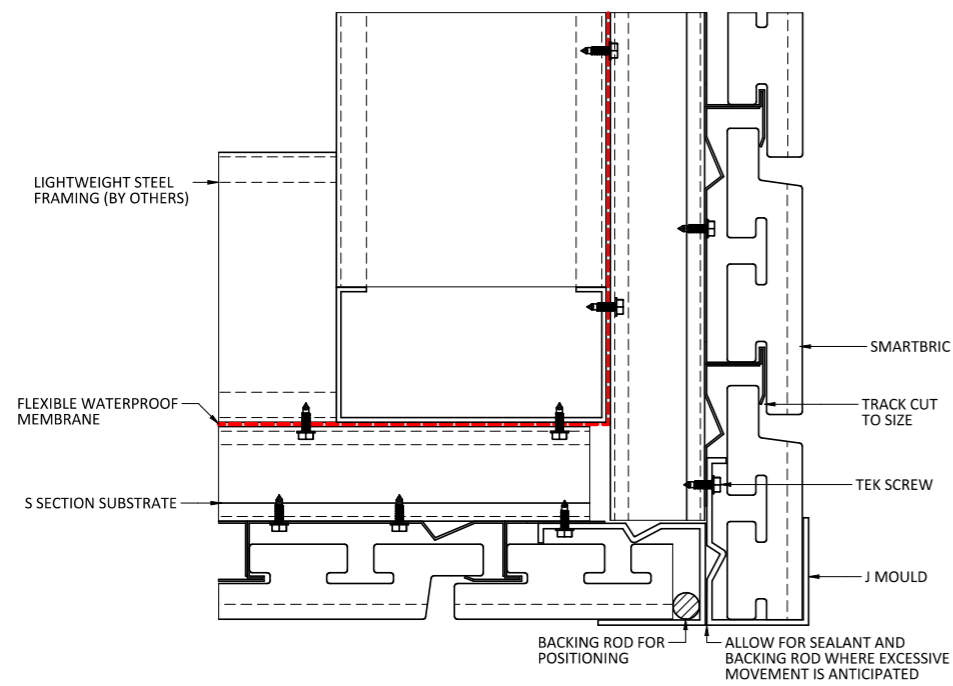

SMARTBRIC CLASSIC WITH RAIL INSTALLATION

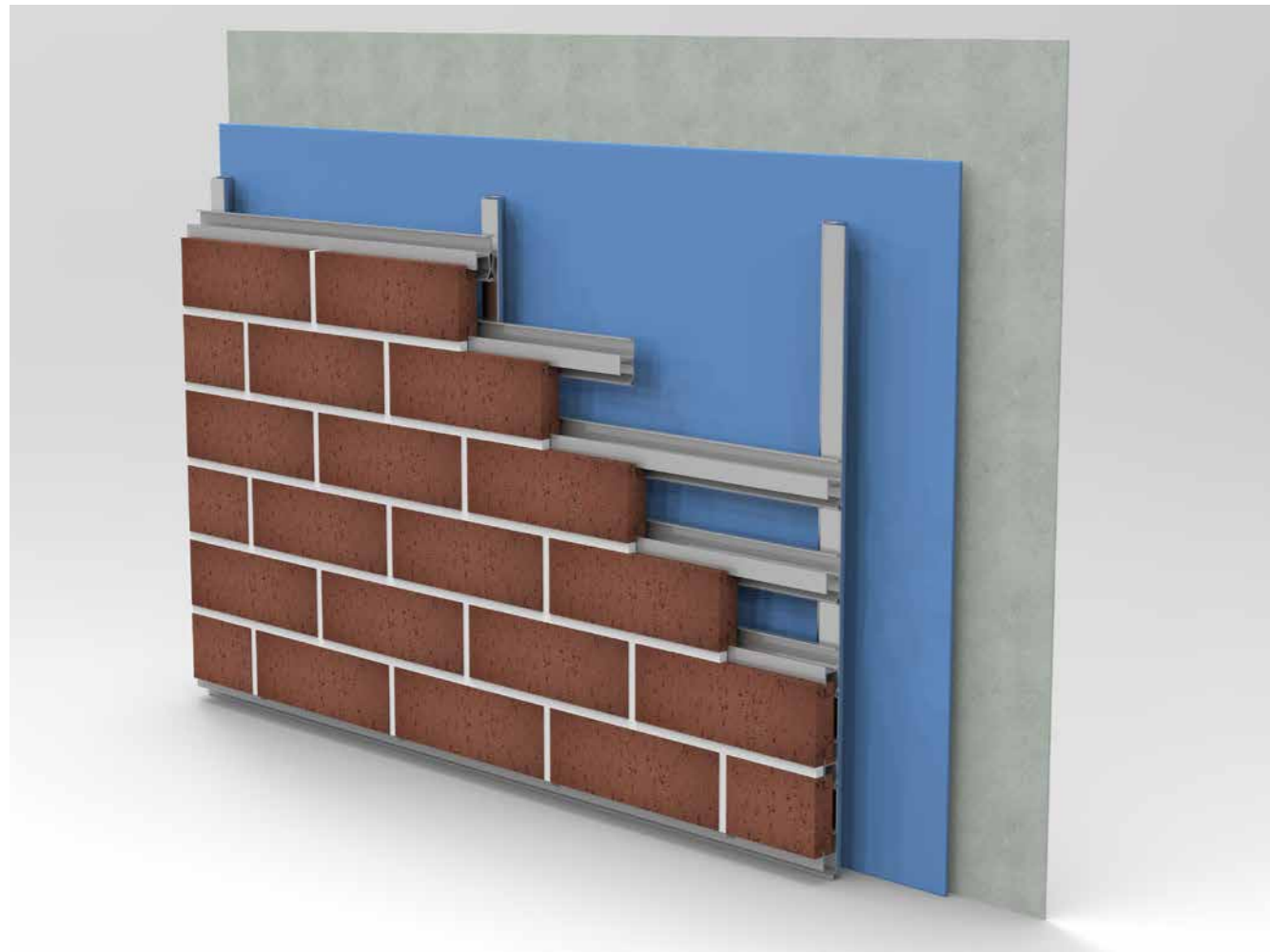

STANDARD RAIL INSTALL

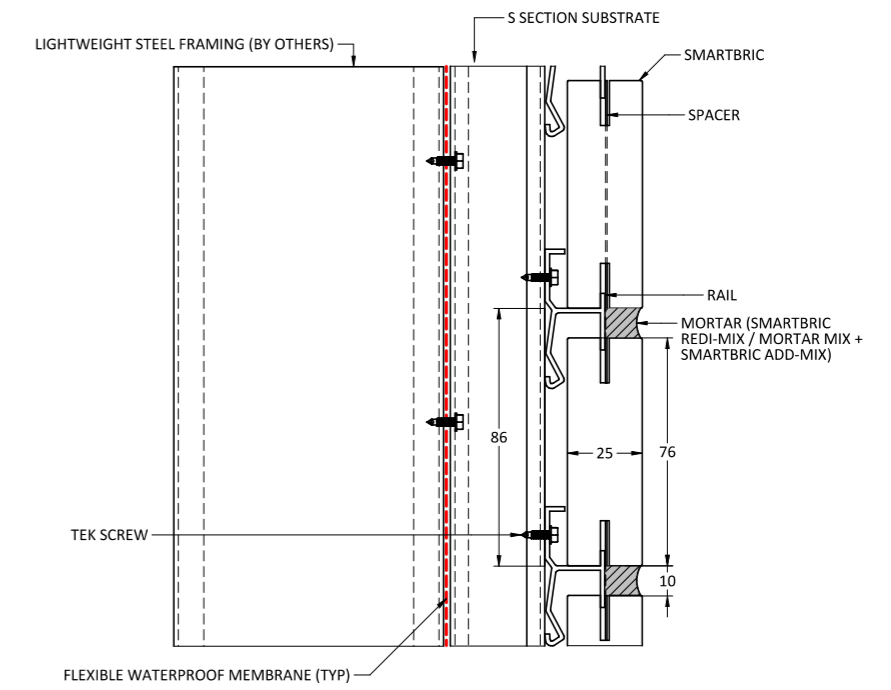

HEAD SLAB JUNCTION

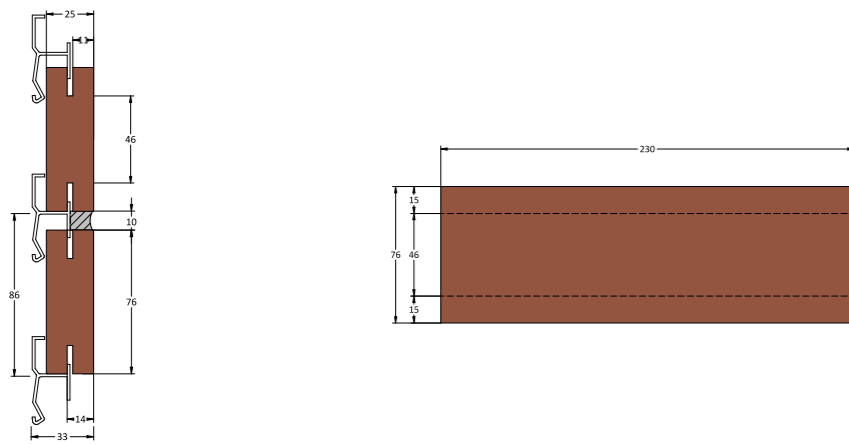
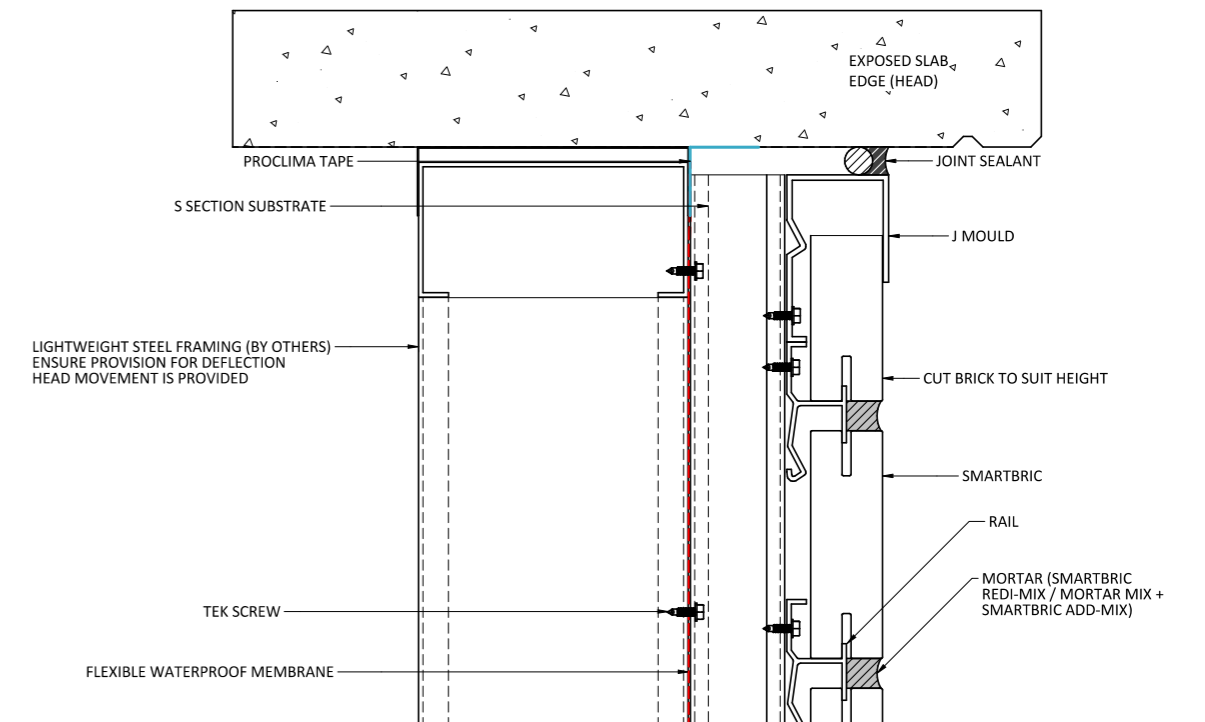

BASE SLAB JUNCTION

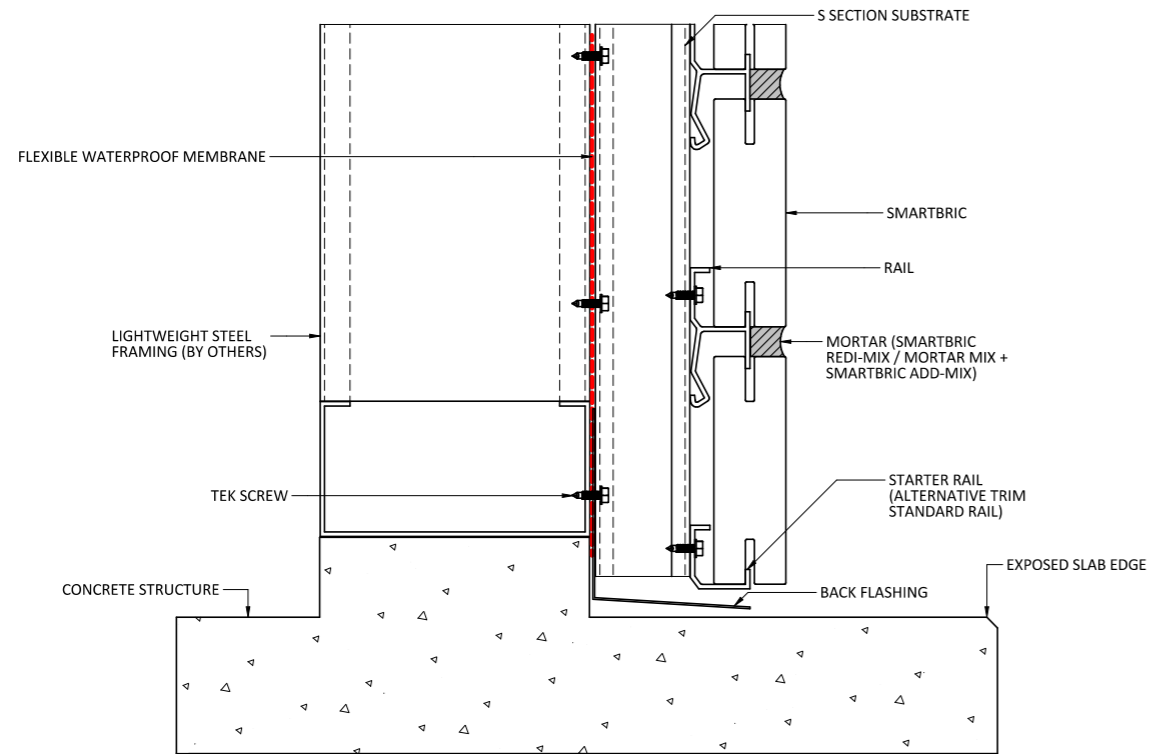

VERTICAL EXPANSION JOINT

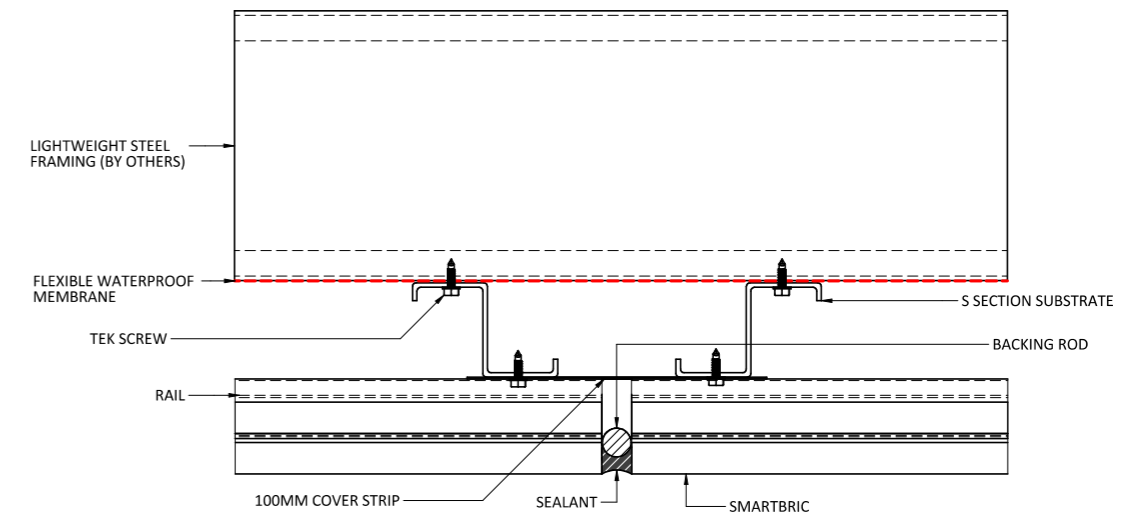

HORIZONTAL EXPANSION JOINT

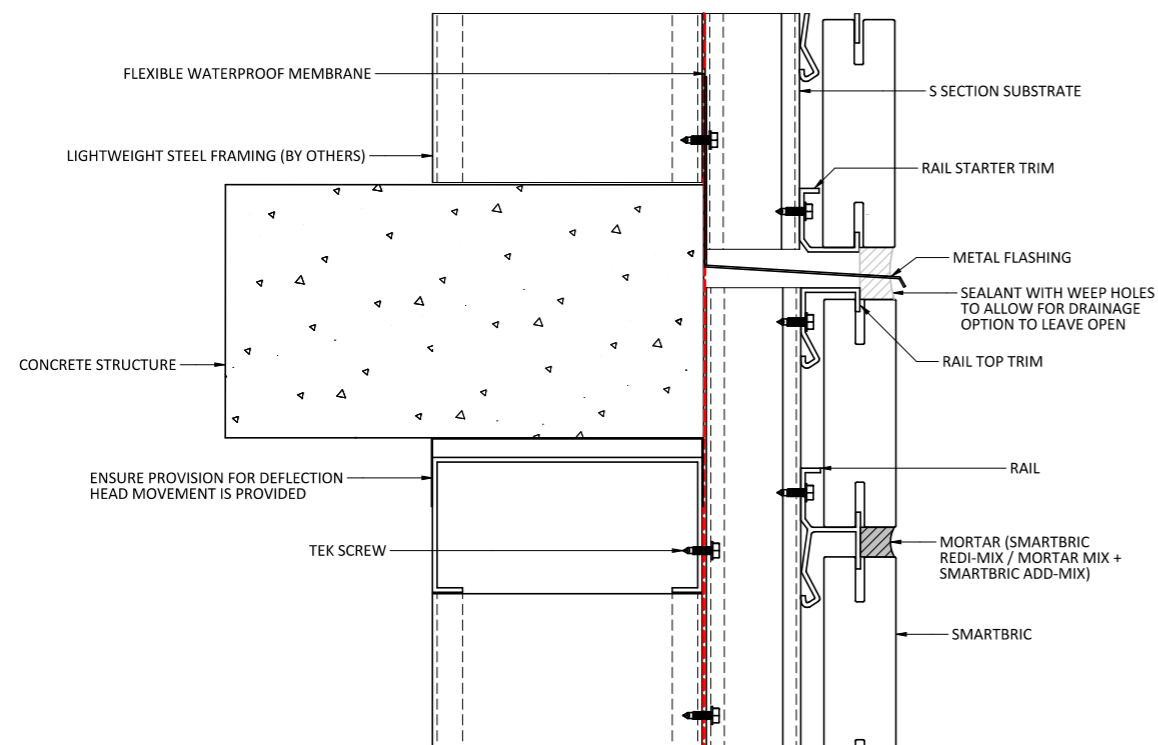

WINDOW HEAD DETAIL

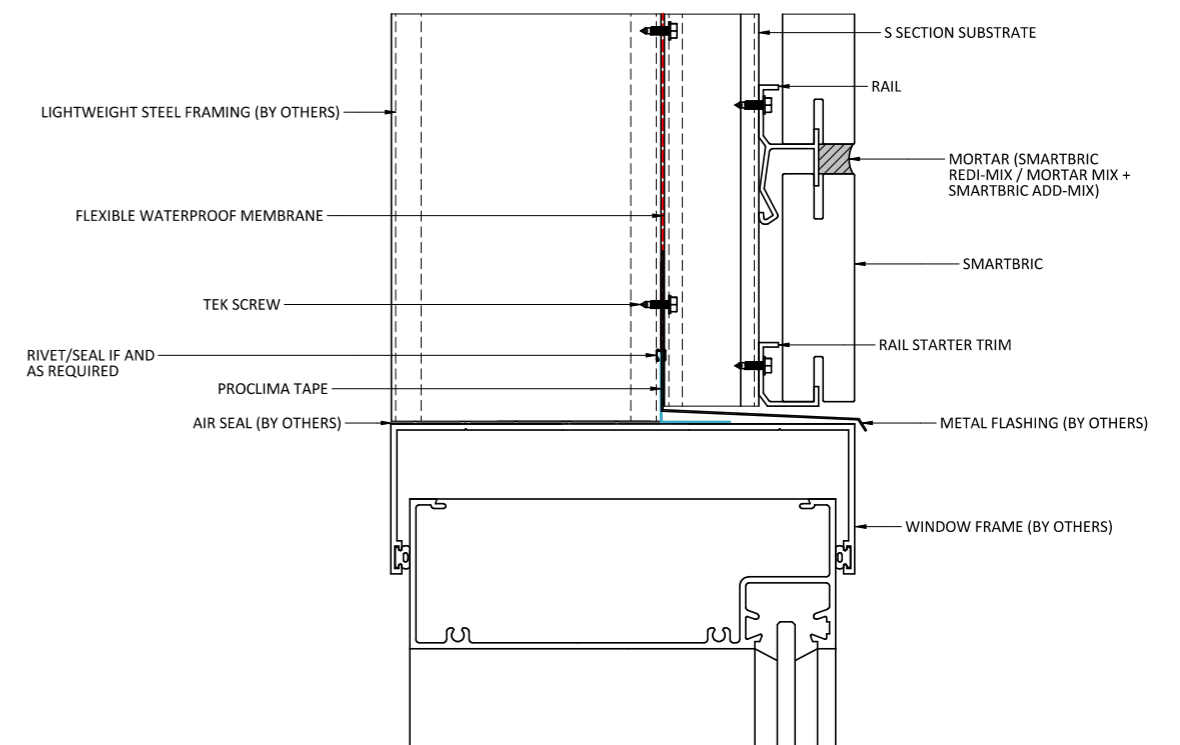

RECESSED WINDOW HEAD DETAIL CORNER BRICK

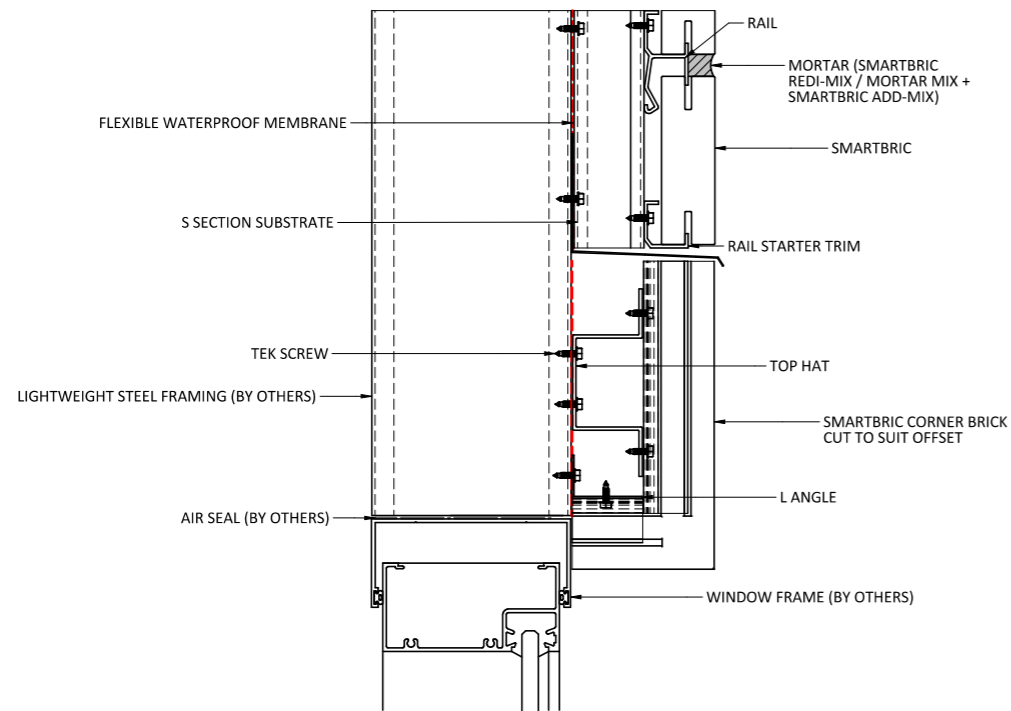

WINDOW SILL DETAIL

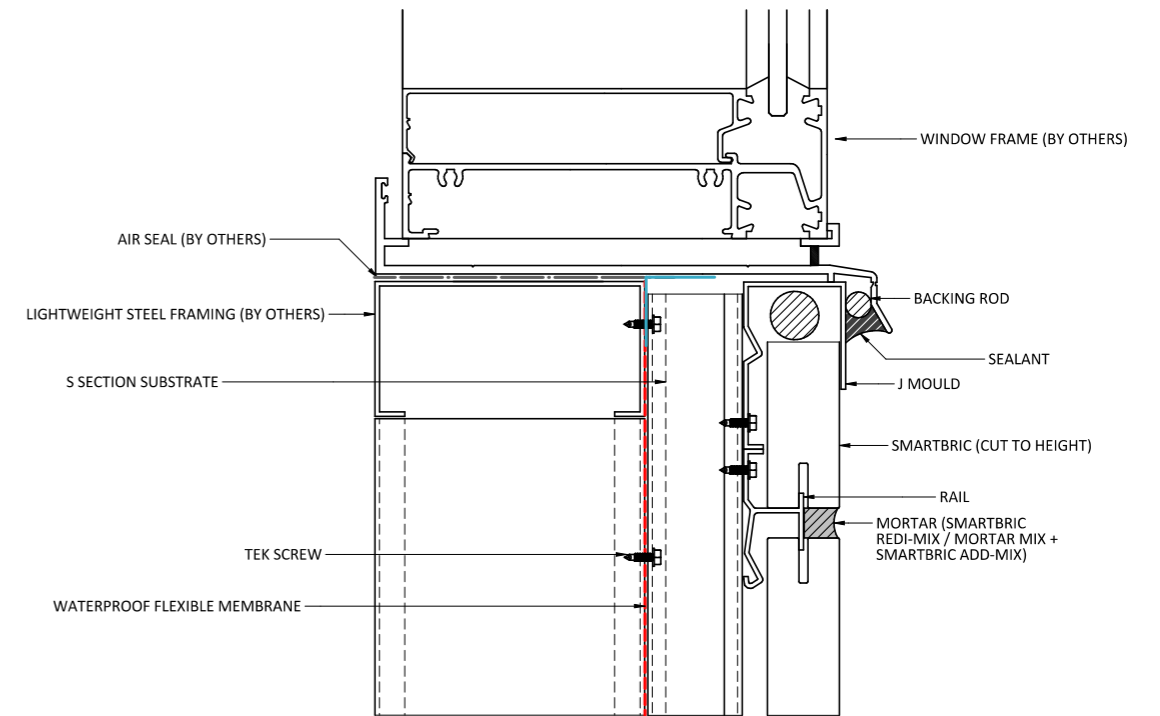

RECESSED WINDOW HEAD DETAIL

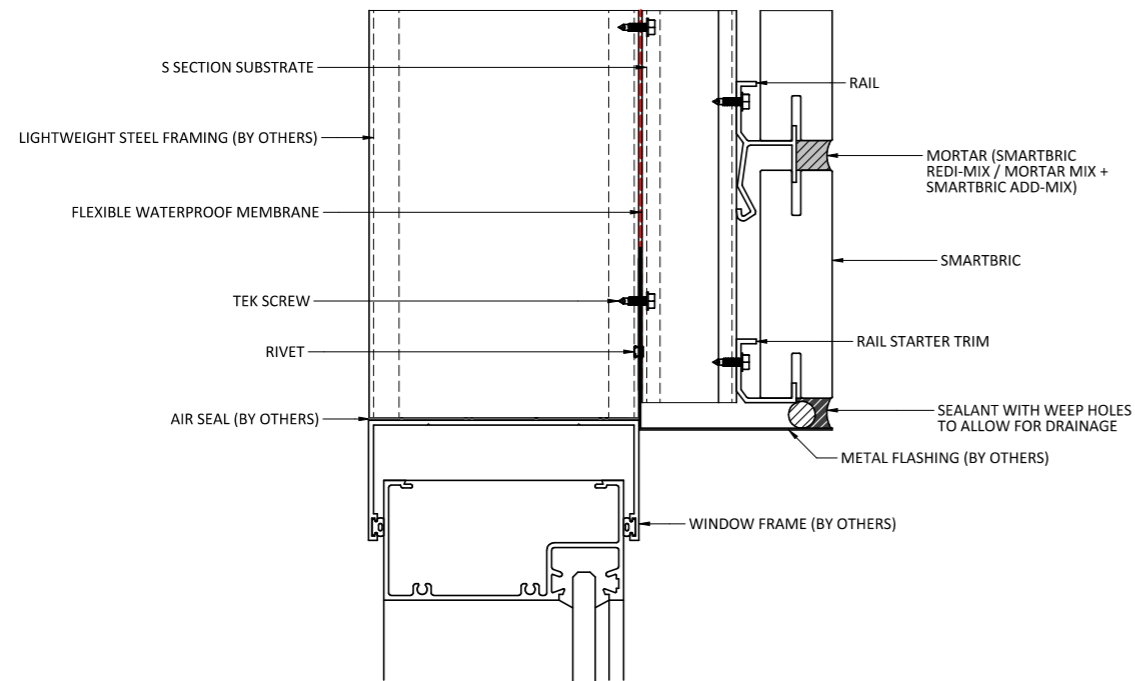

RECESSED WINDOW SILL DETAIL CORNER BRICK

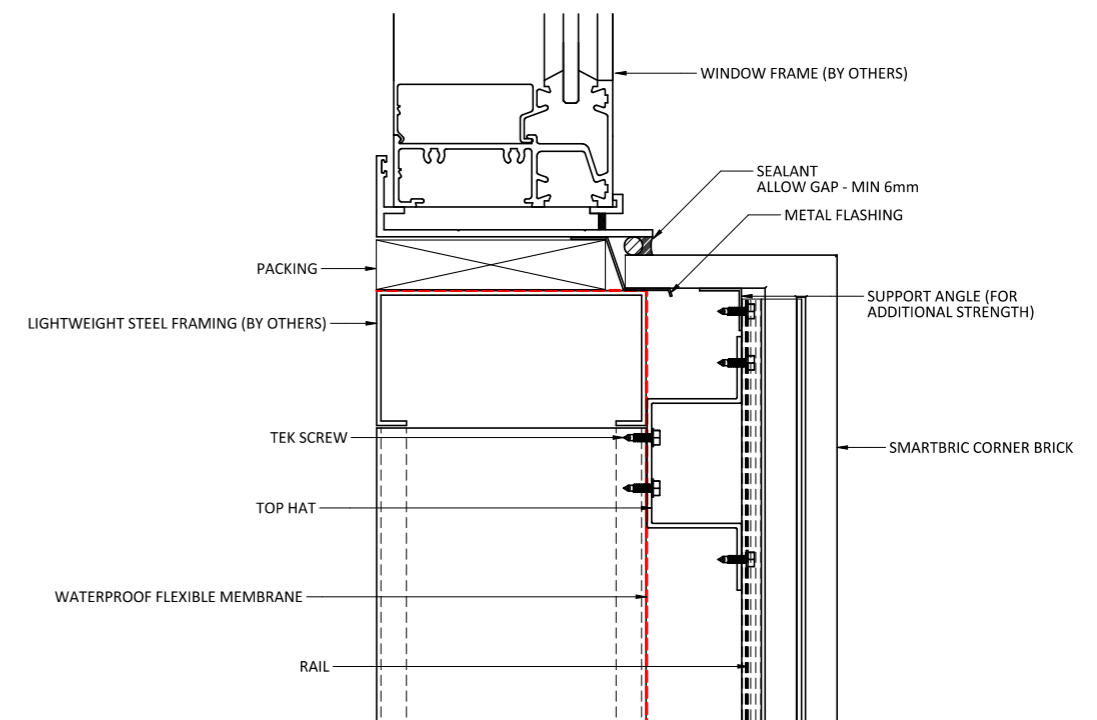

RECESSED WINDOW SILL DETAIL

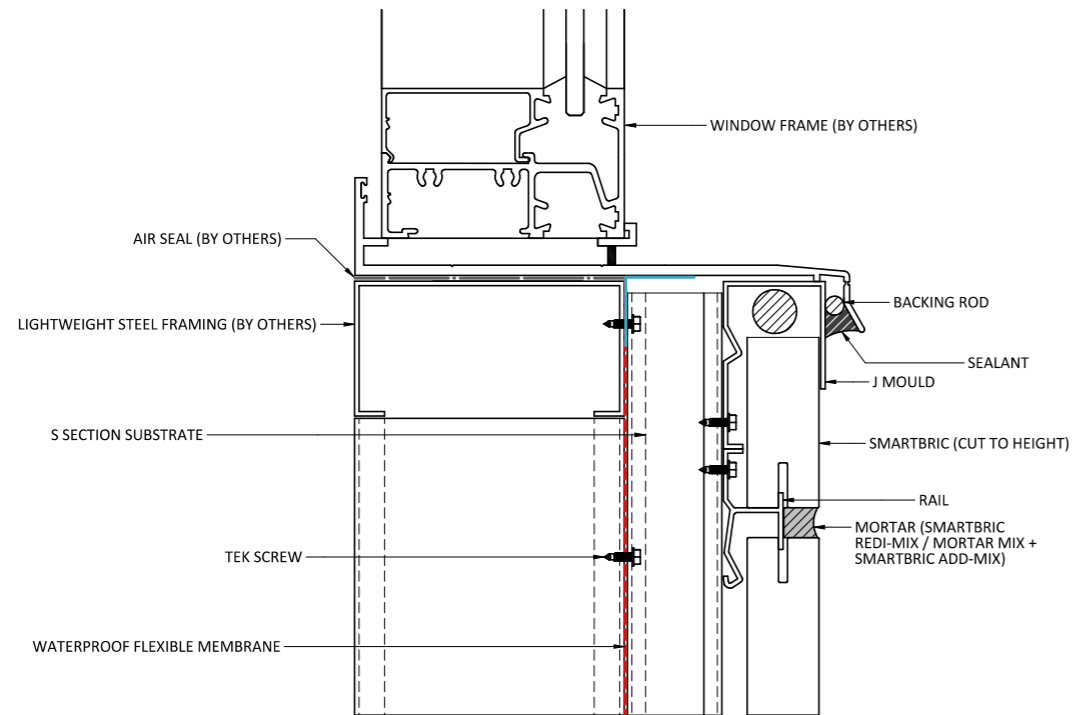

RECESSED WINDOW JAMB DETAIL CORNER BRICK CUT

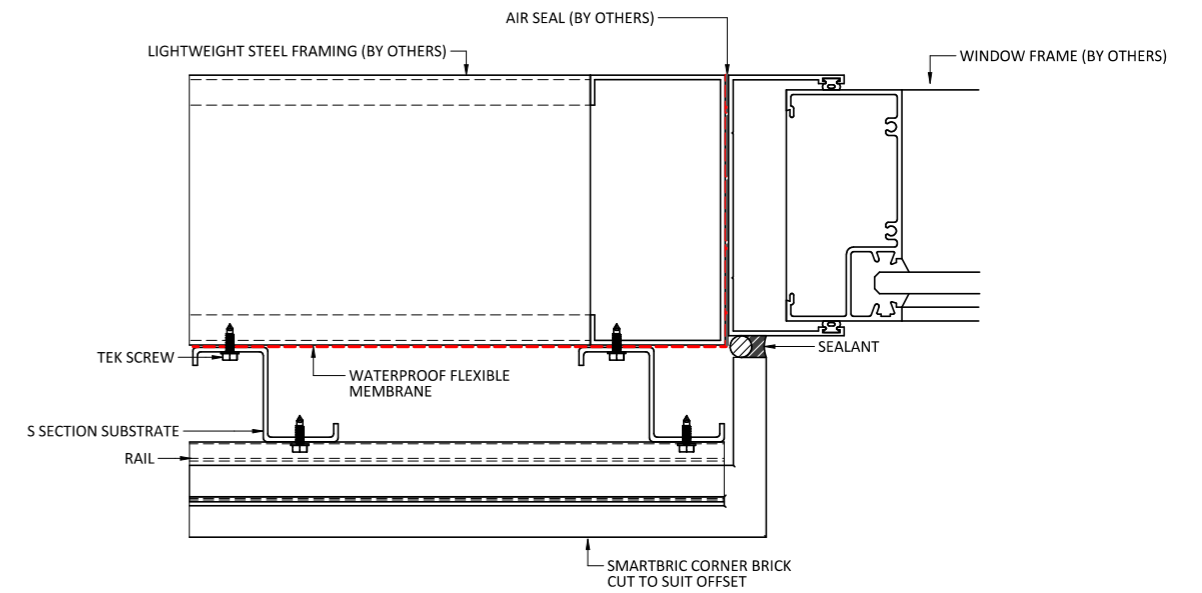

WINDOW JAMB DETAIL

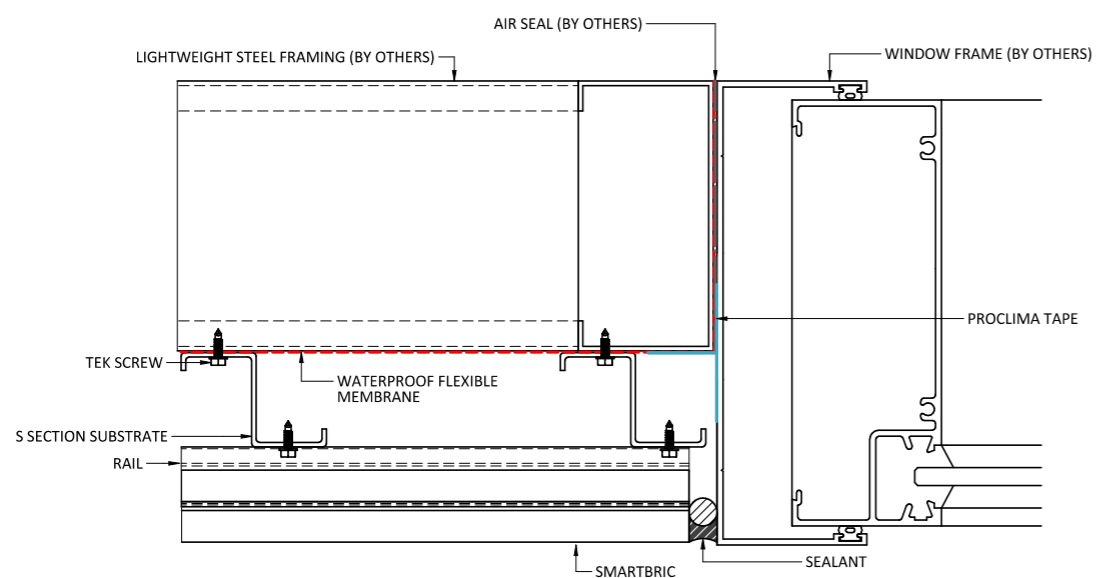

RECESSED WINDOW JAMB DETAIL FULL CORNER BRICK

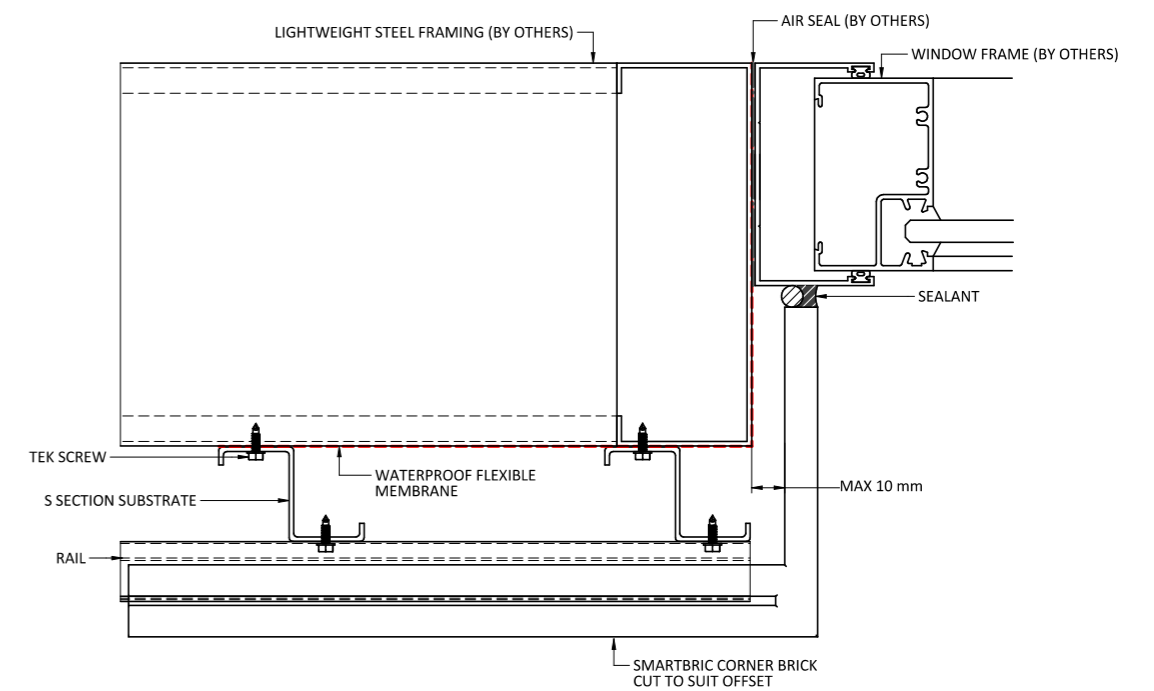

RECESSED WINDOW JAMB DETAIL METAL REVEAL

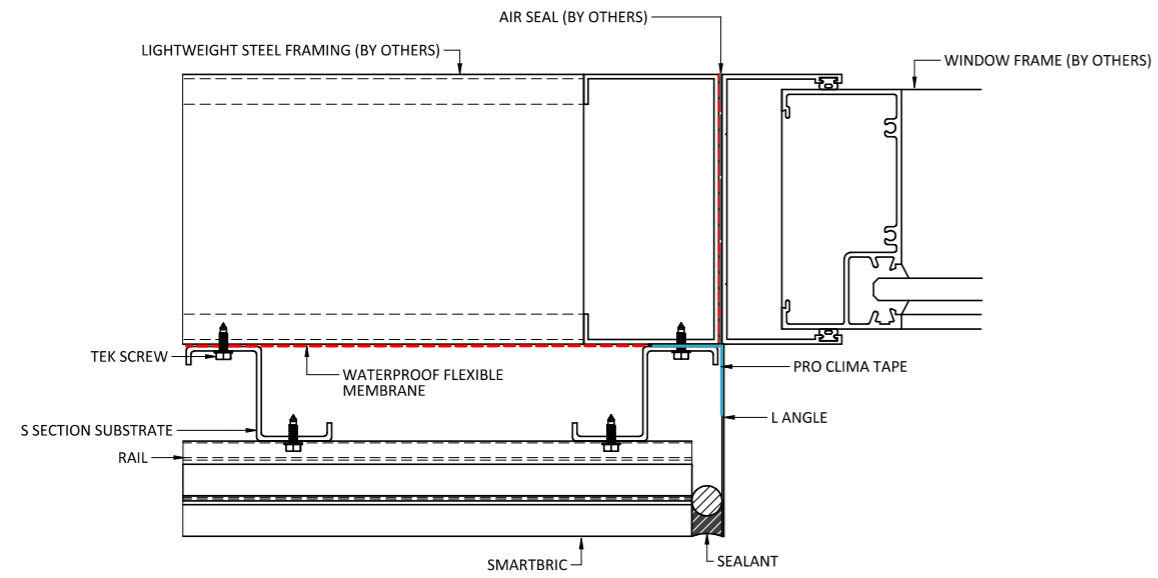

EXTERNAL BRICK CORNER

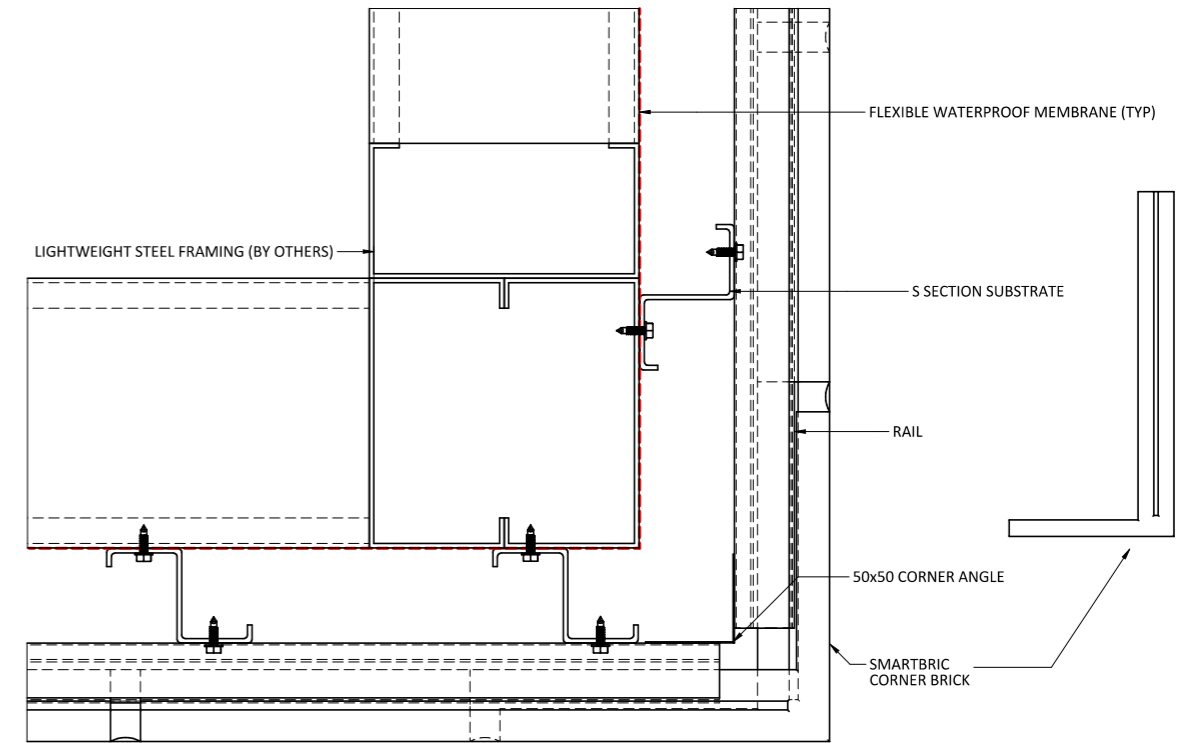

DOOR JAMB DETAIL

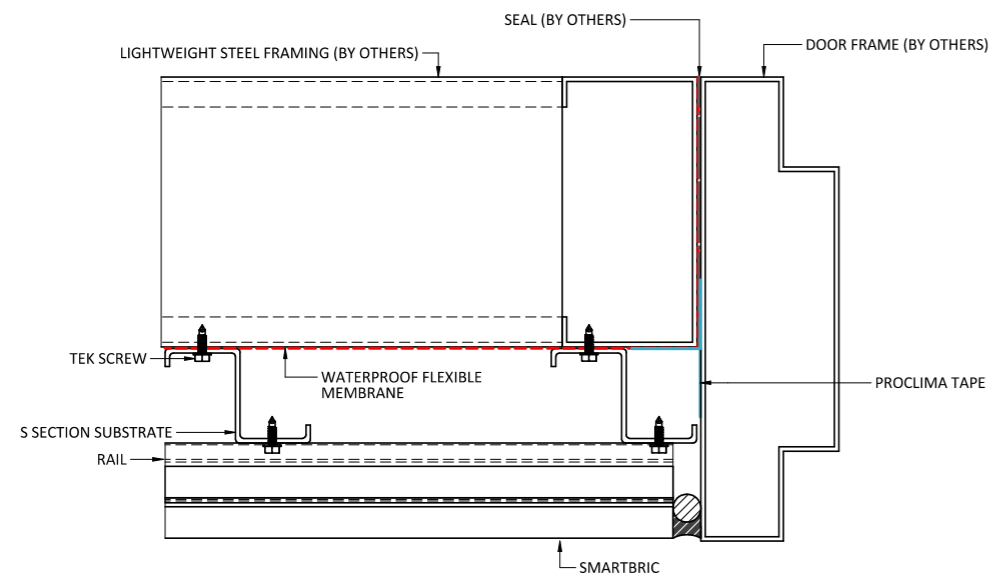

EXTERNAL MITER CORNER

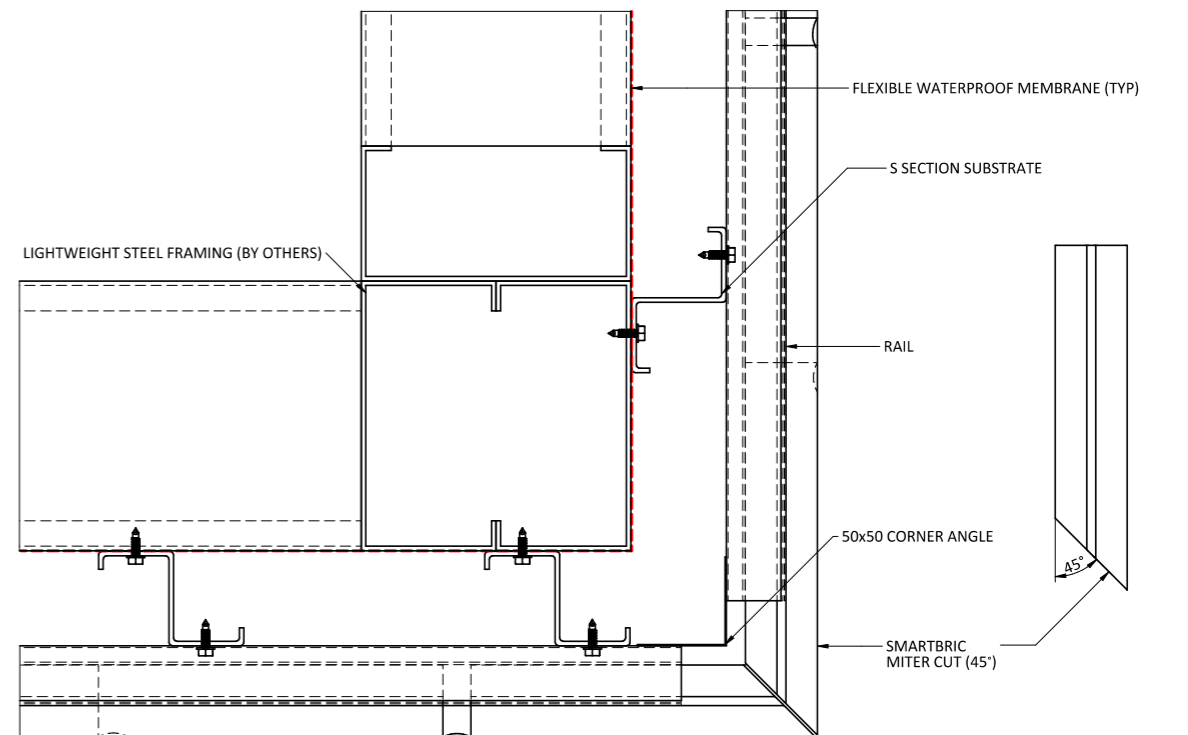

EXTERNAL EXTRUSION CORNER

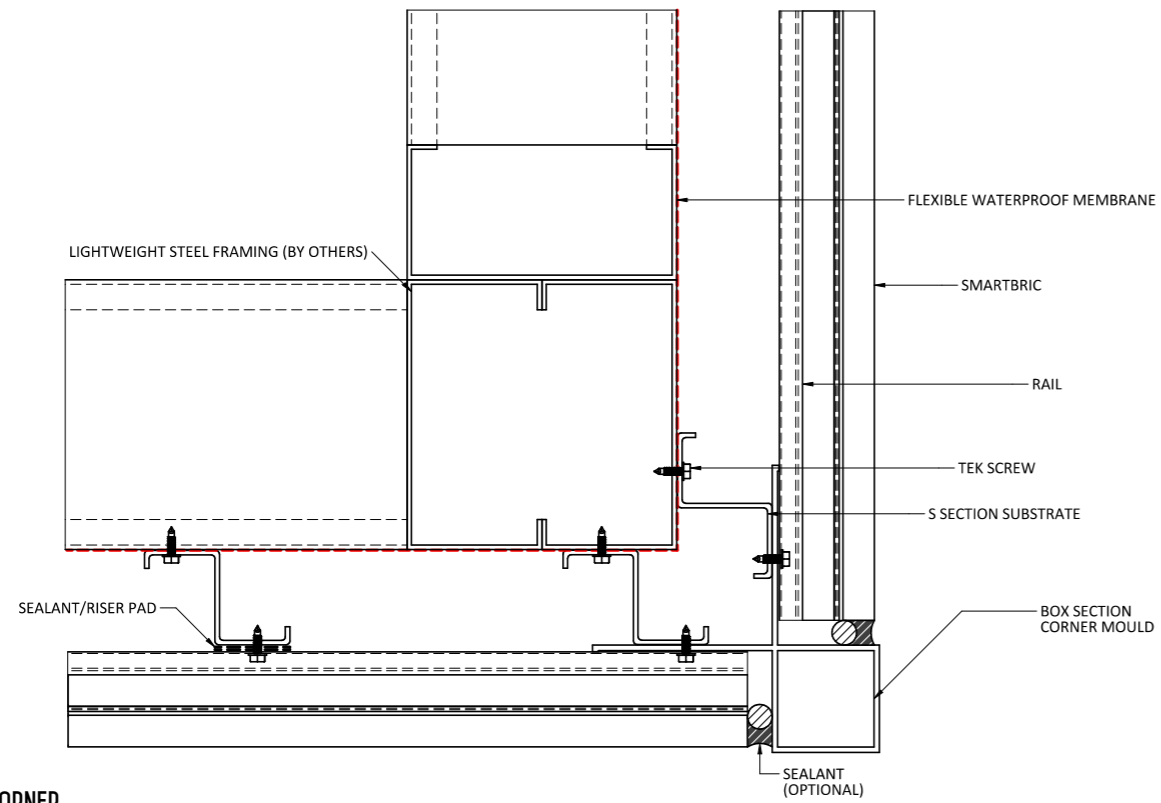

INTERNAL EXTRUSION CORNER

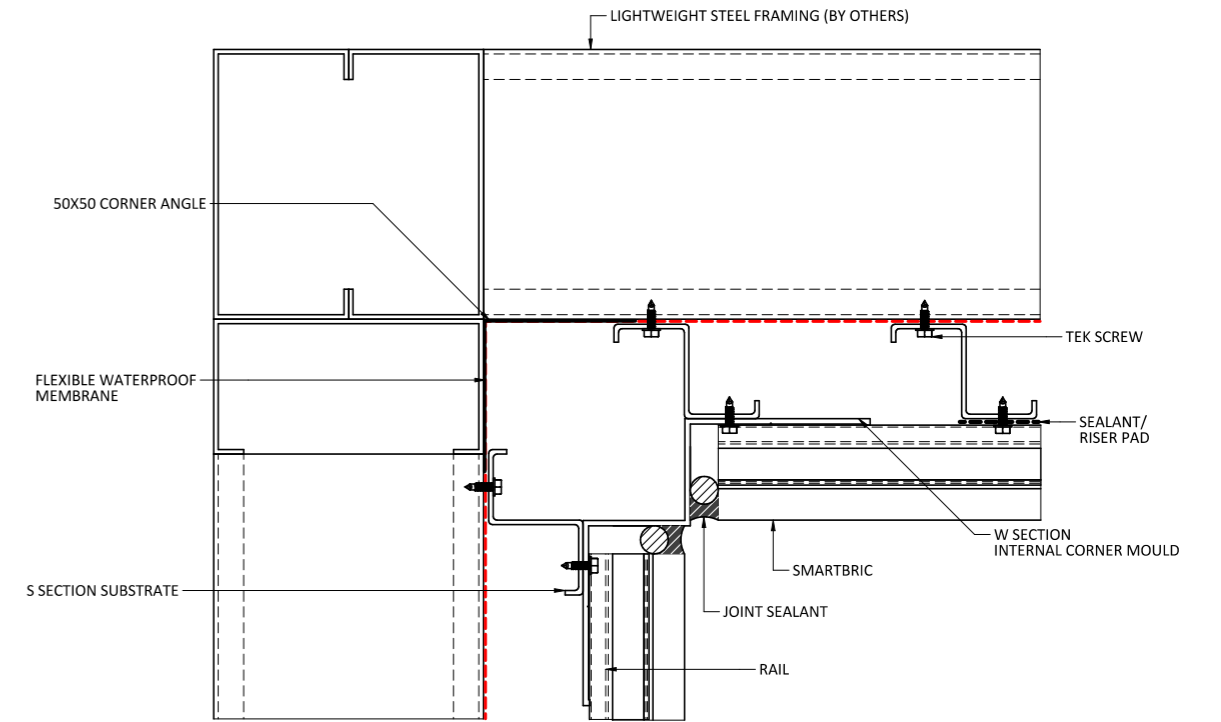

INTERNAL CORNER

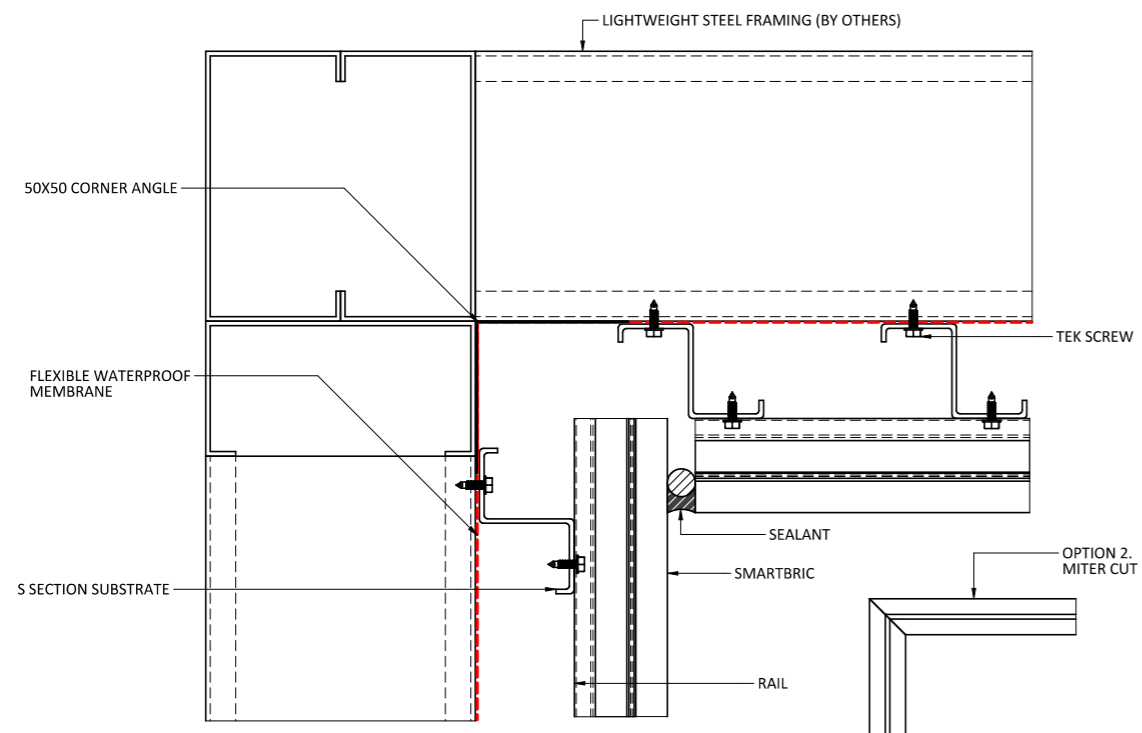

SOFFIT INTERNAL

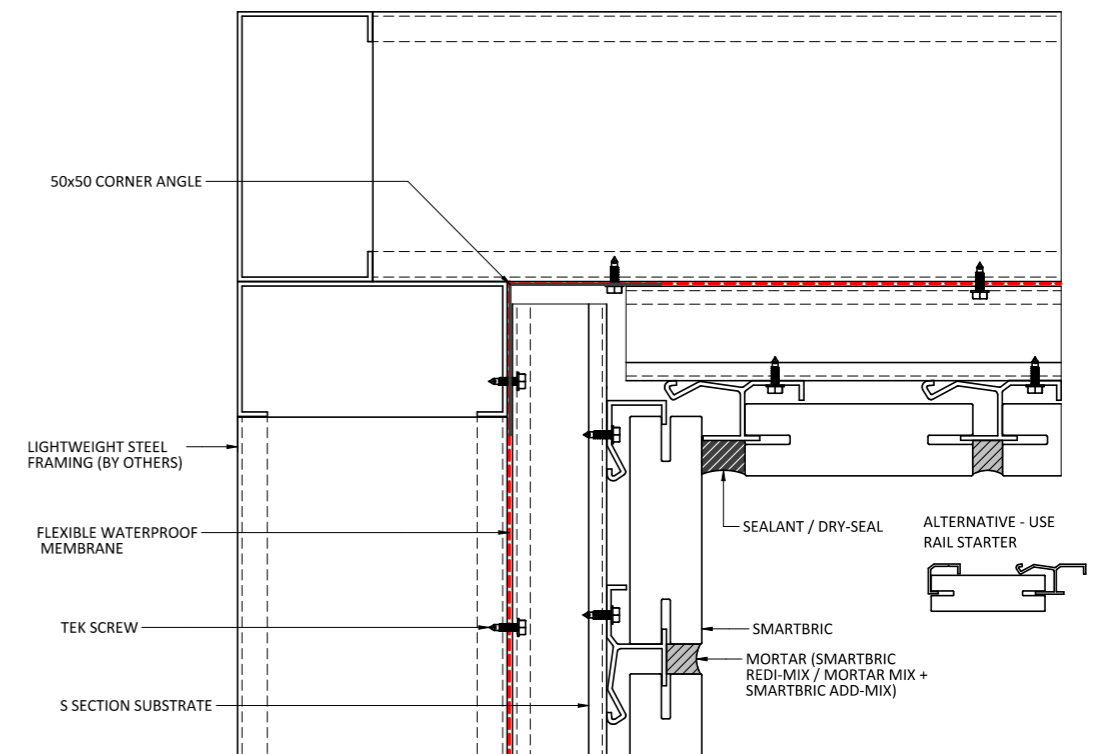

SOFFIT EXTERNAL

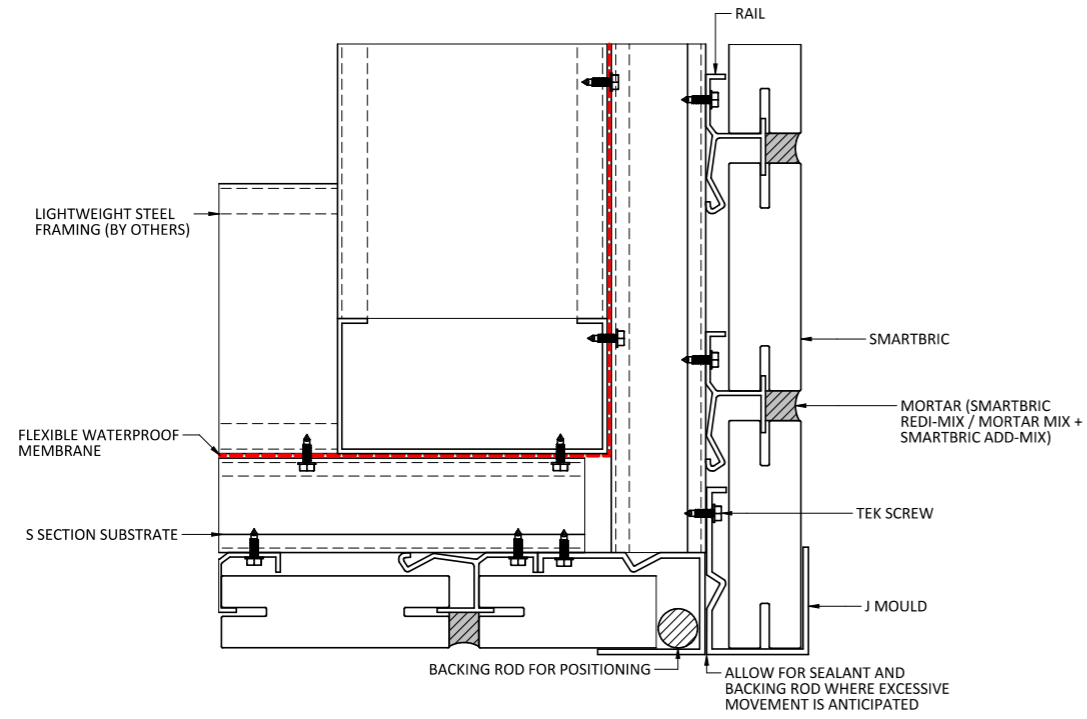

PARAPET DETAIL

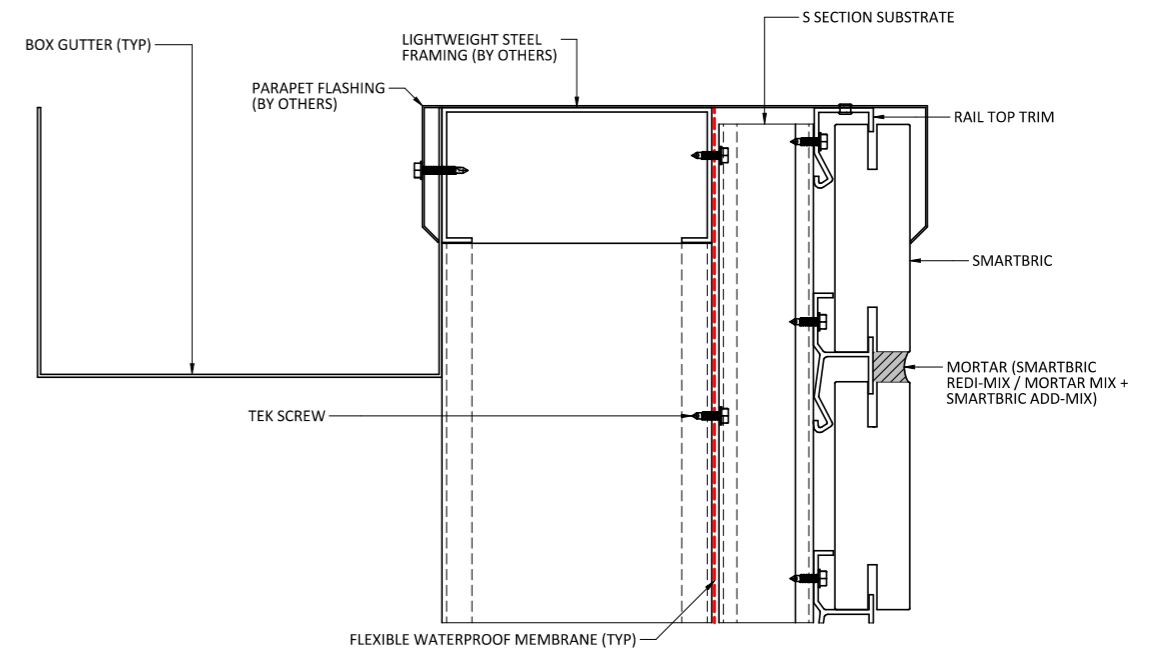

SMARTBRIC CLASSIC WITH TRACK INSTALLATION

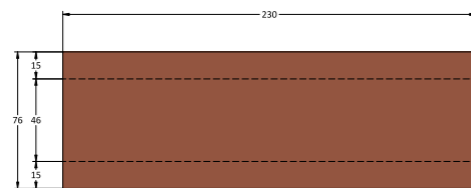
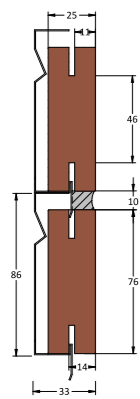
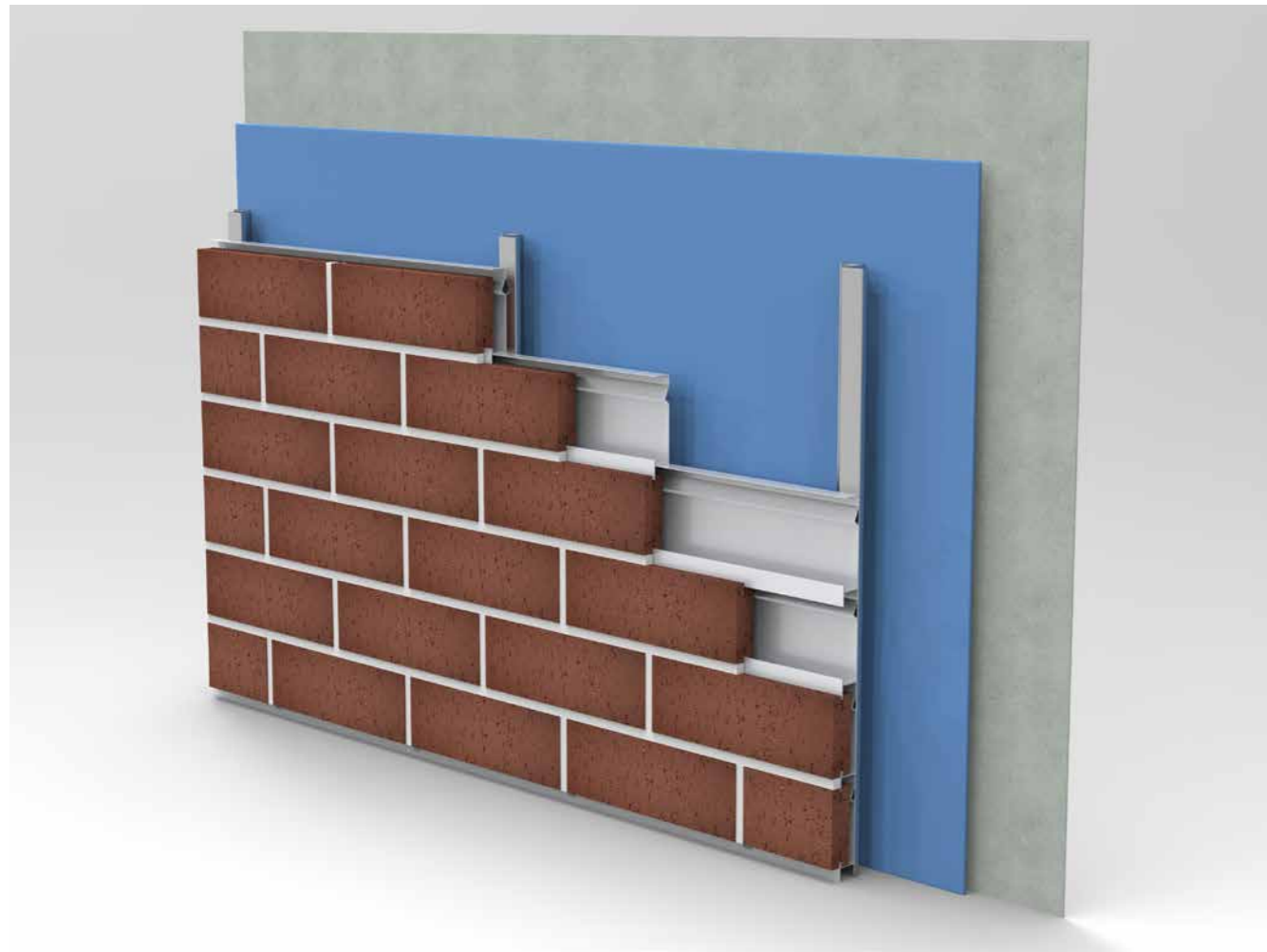

STANDARD TRACK INSTALL

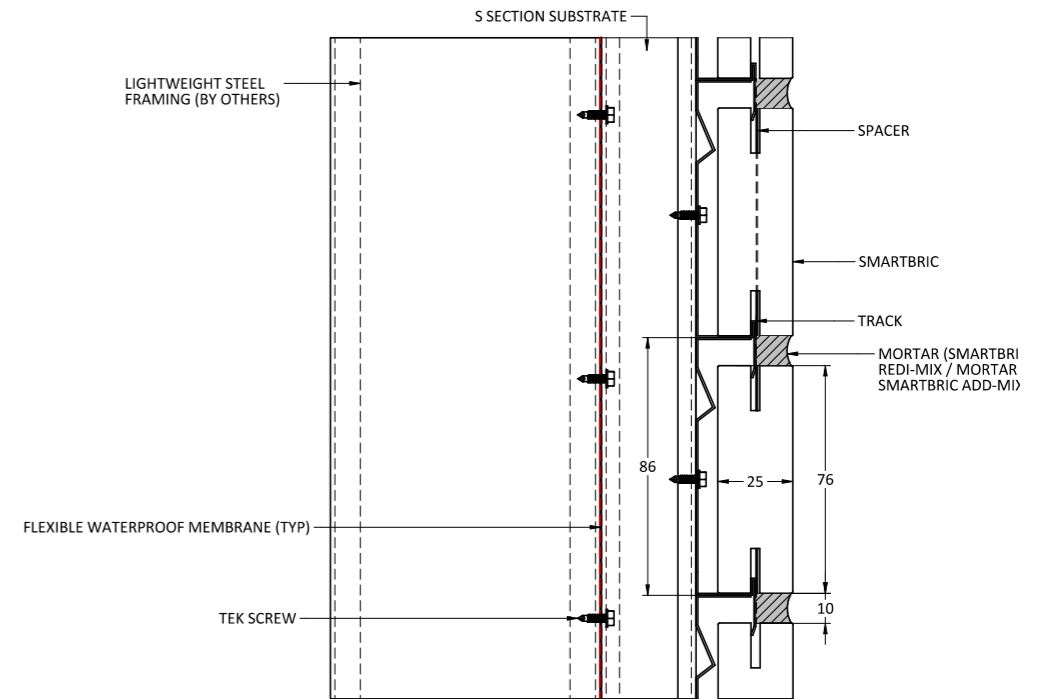

HEAD SLAB JUNCTION

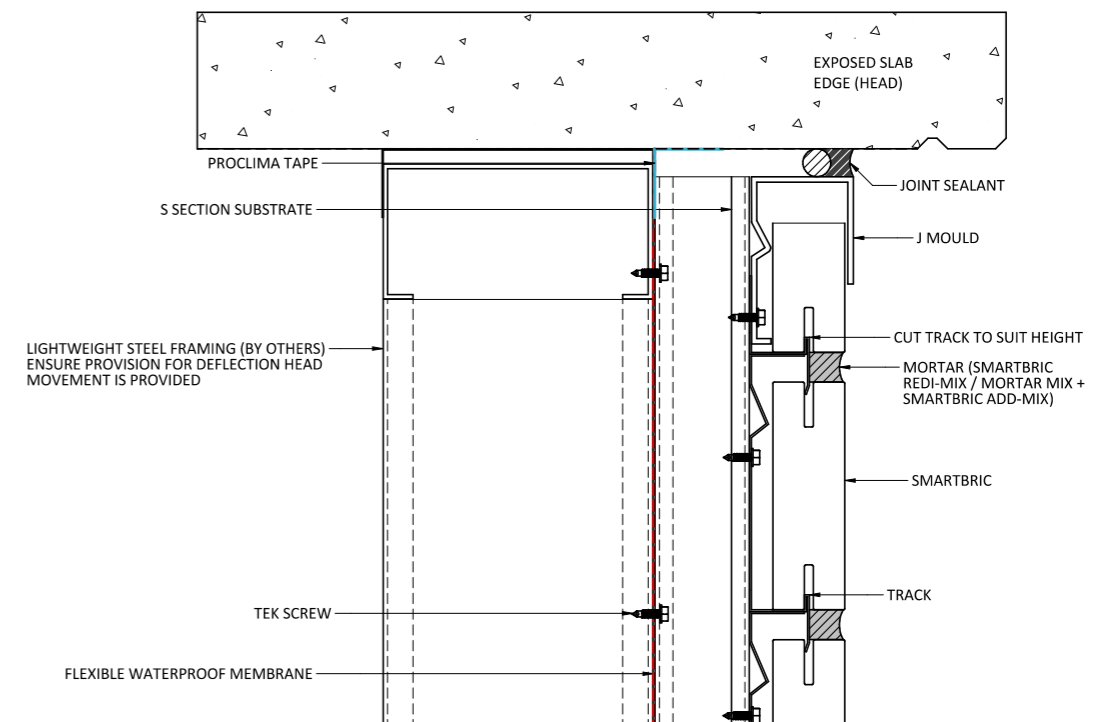

BASE SLAB JUNCTION

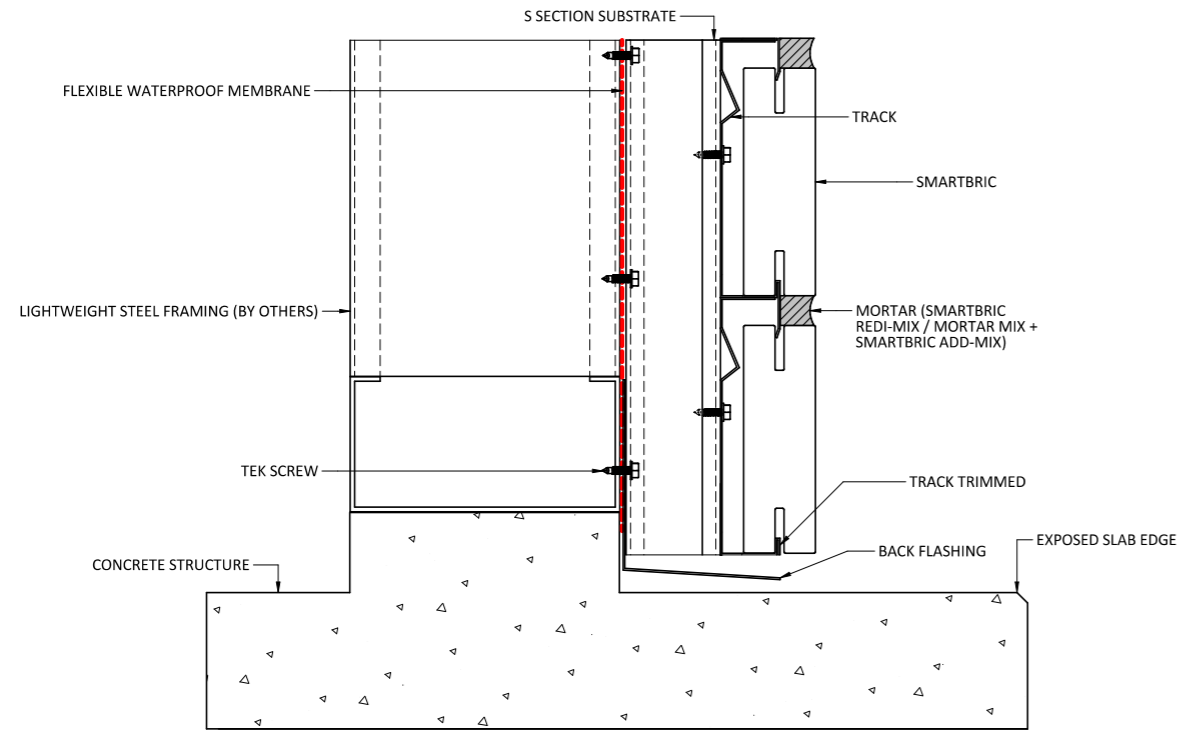

VERTICAL EXPANSION JOINT

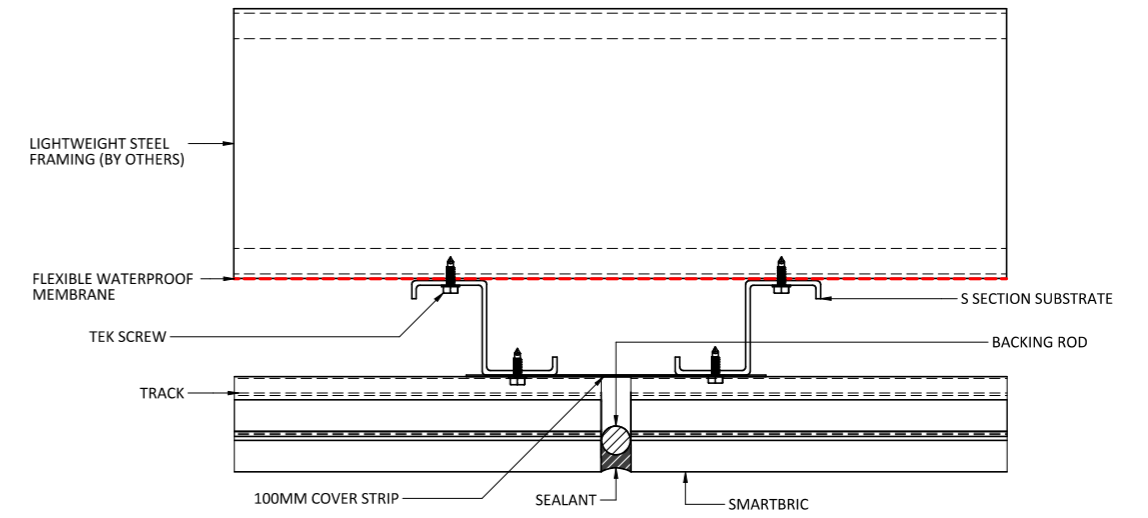

HORIZONTAL EXPANSION JOINT

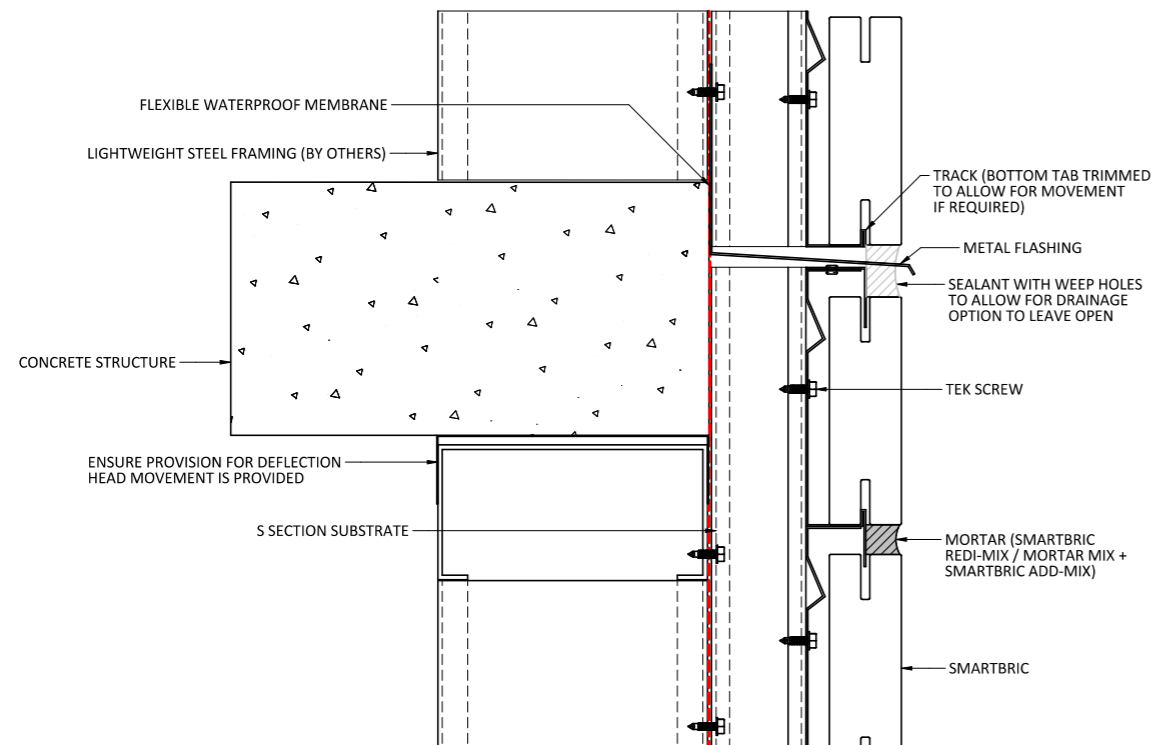

WINDOW HEAD DETAIL

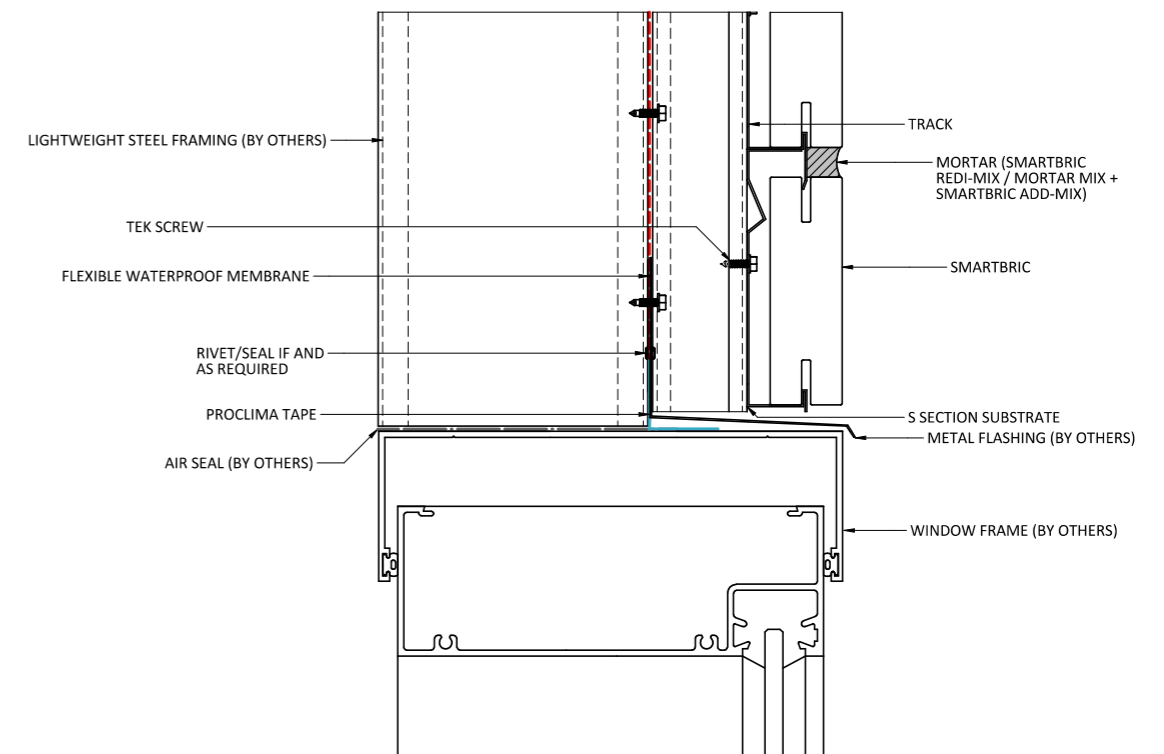

RECESSED WINDOW HEAD DETAIL

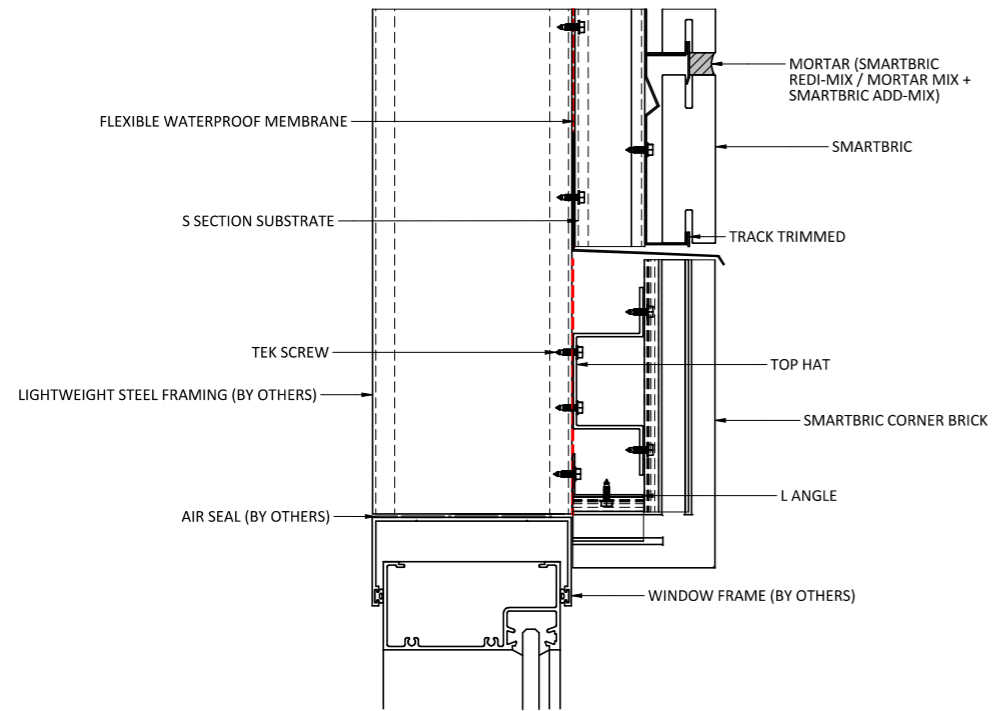

WINDOW SILL DETAIL

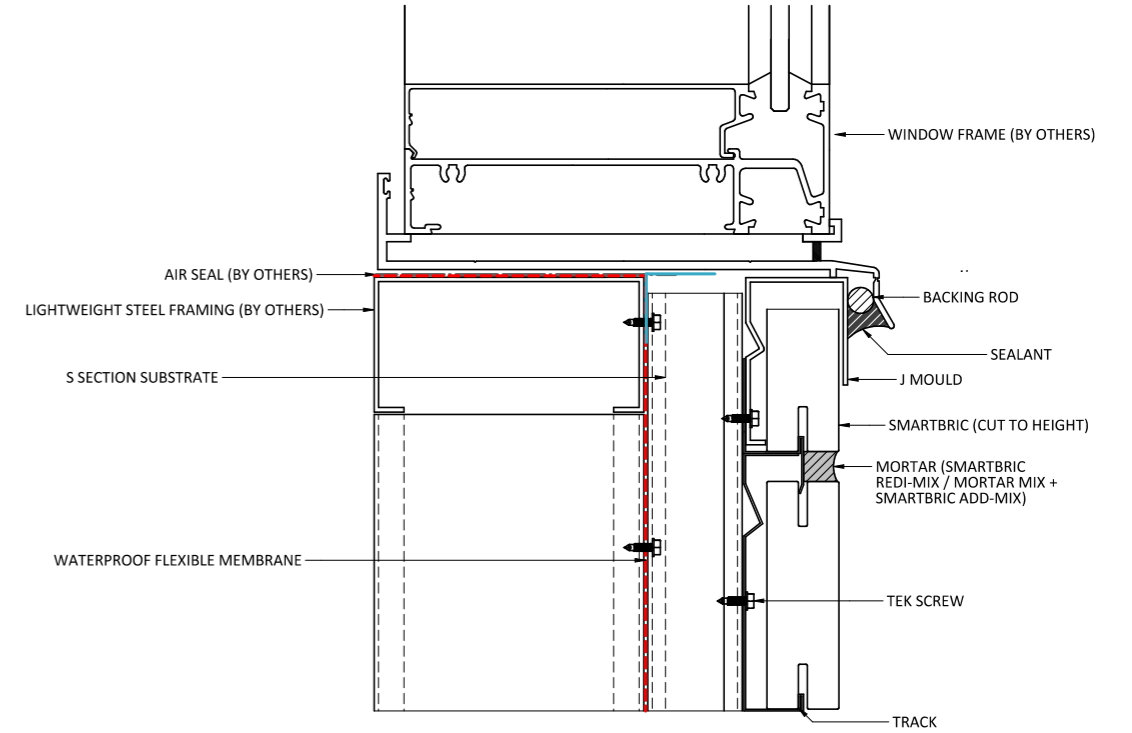

RECESSED WINDOW HEAD DETAIL

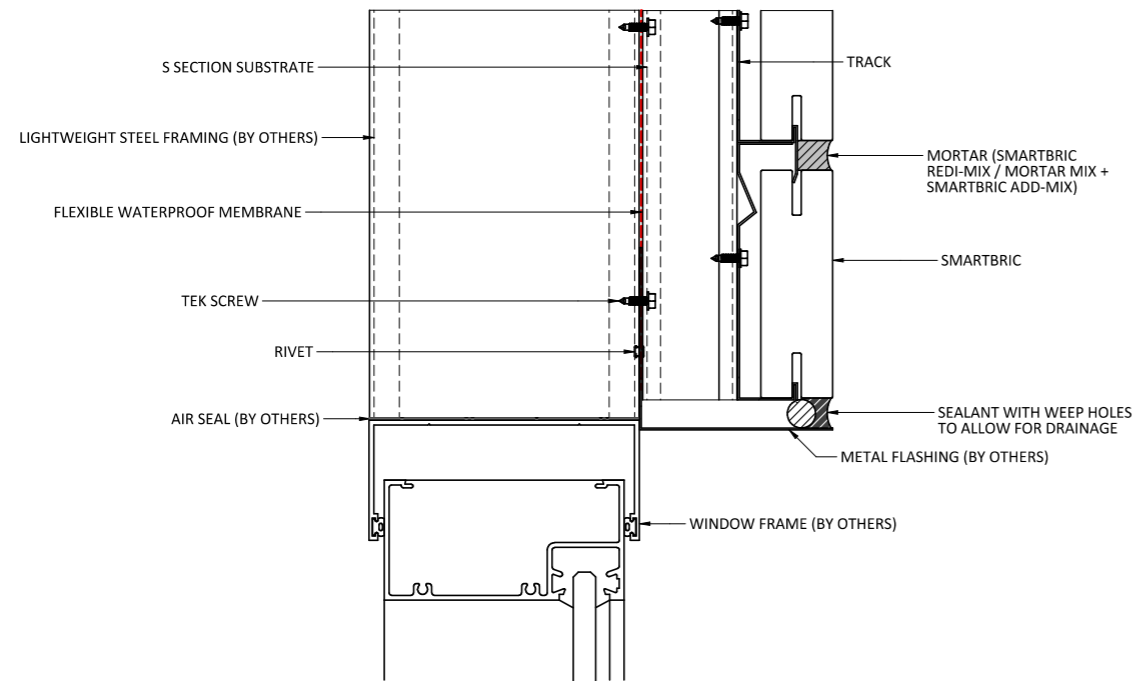

RECESSED WINDOW SILL DETAIL CORNER BRICK

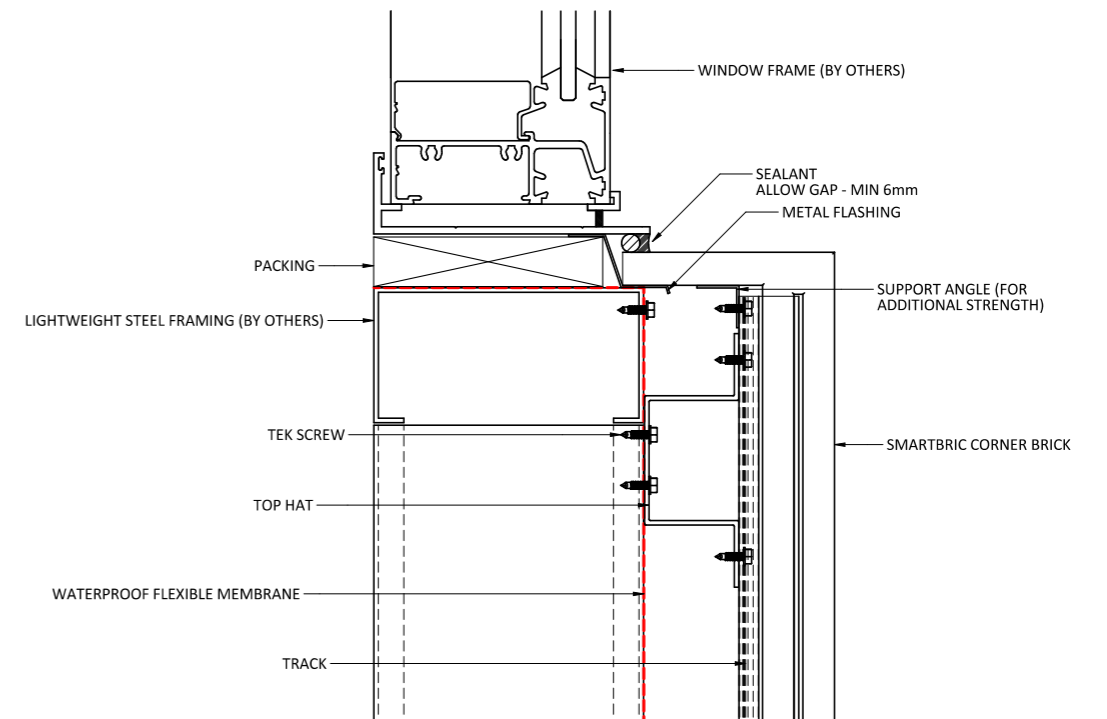

RECESSED WINDOW SILL DETAIL

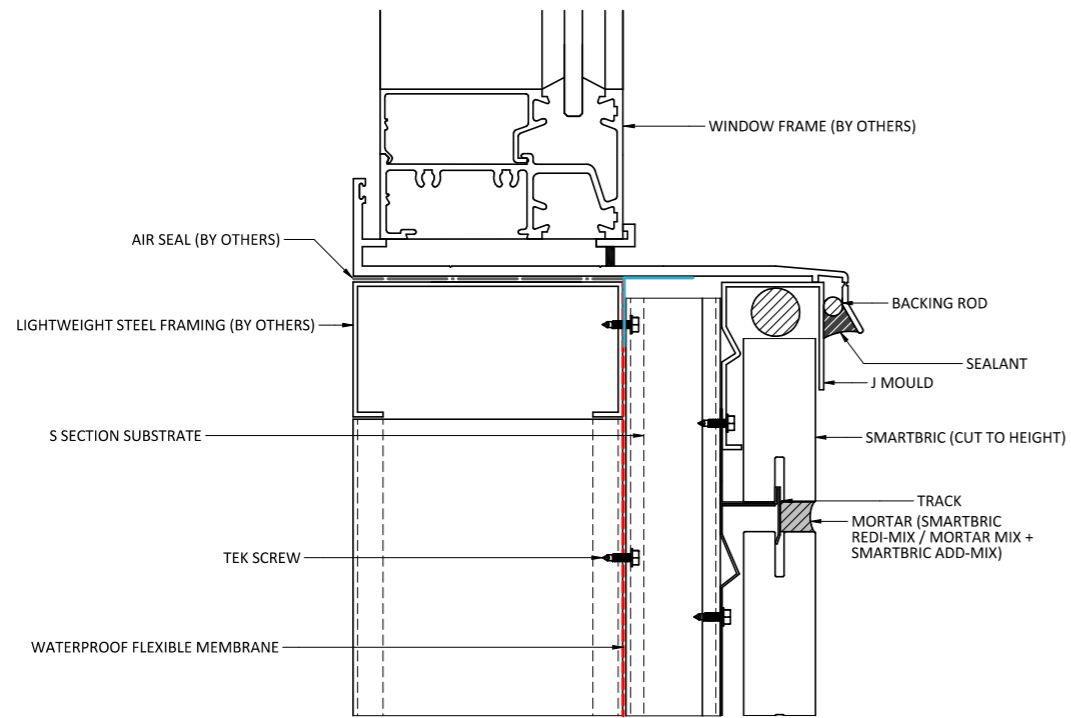

RECESSED WINDOW JAMB DETAIL

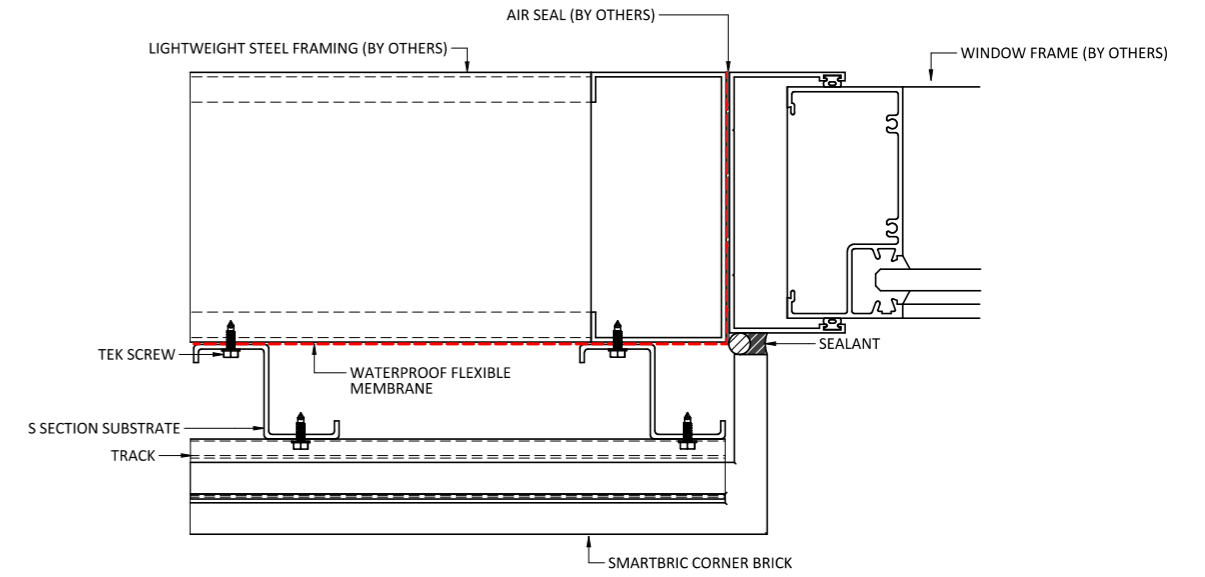

WINDOW JAMB DETAIL

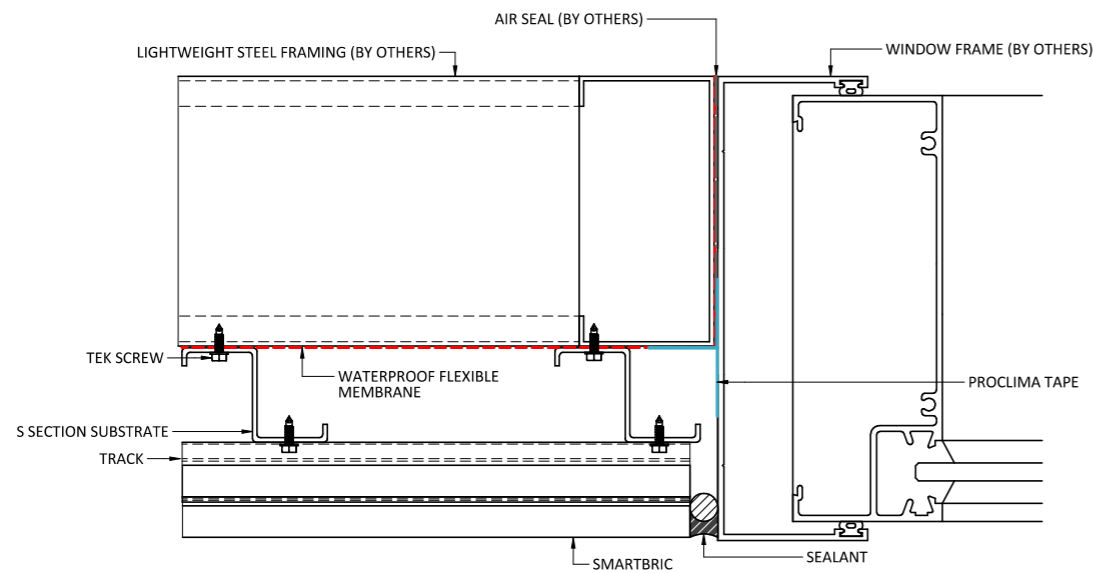

RECESSED WINDOW JAMB DETAIL FULL CORNER BRICK

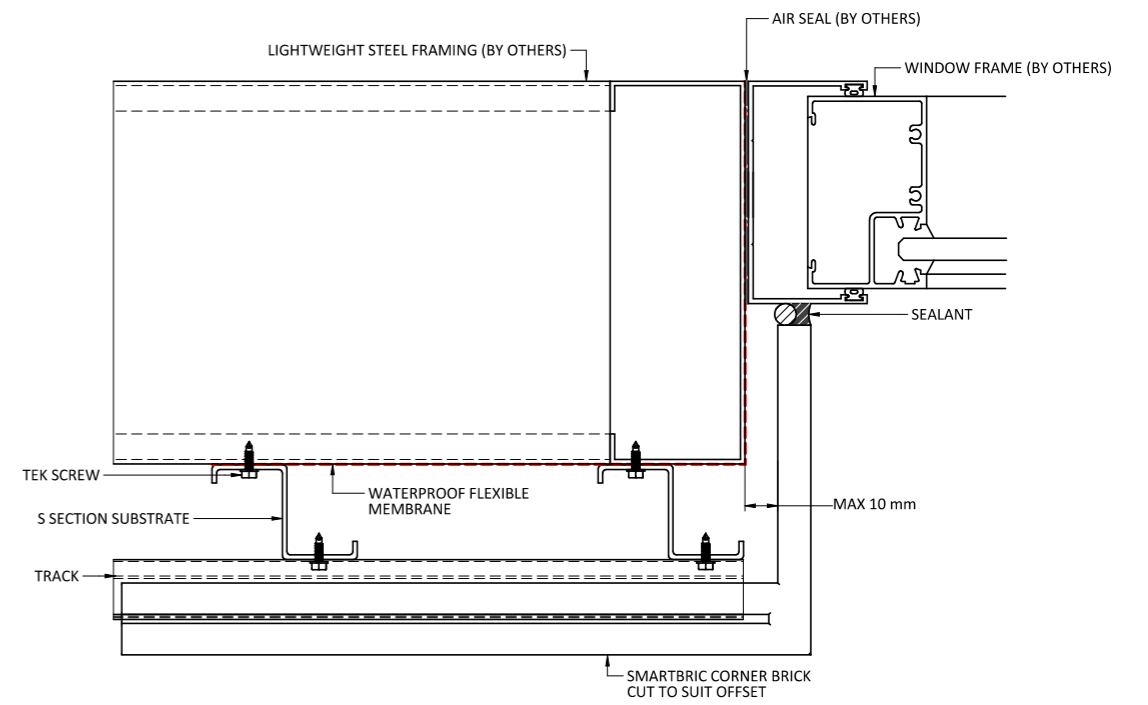

RECESSED WINDOW JAMB DETAIL METAL REVEAL

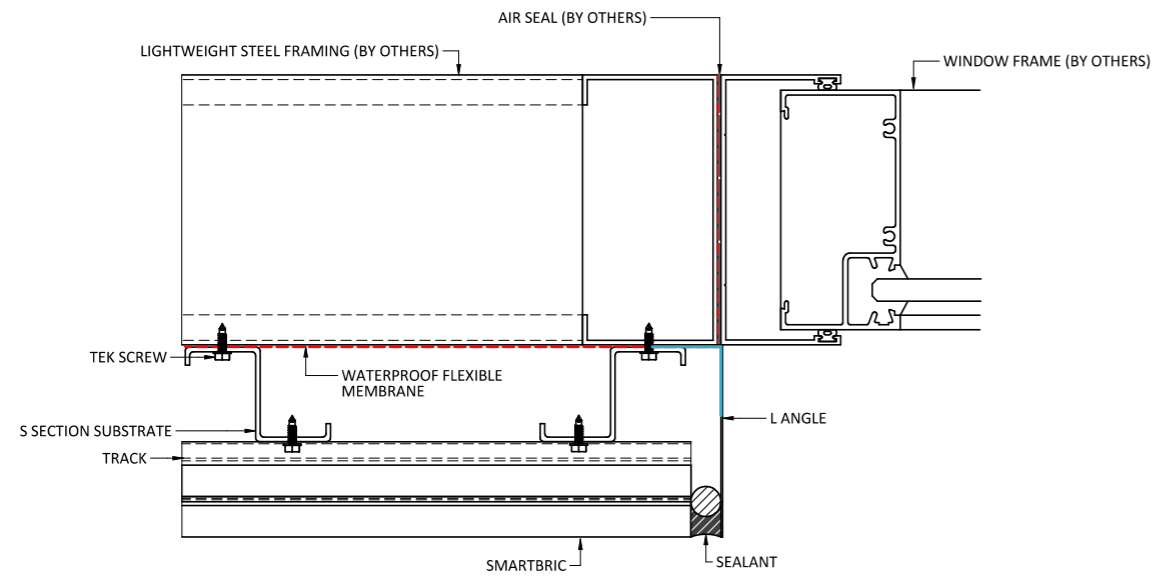

EXTERNAL BRICK CORNER

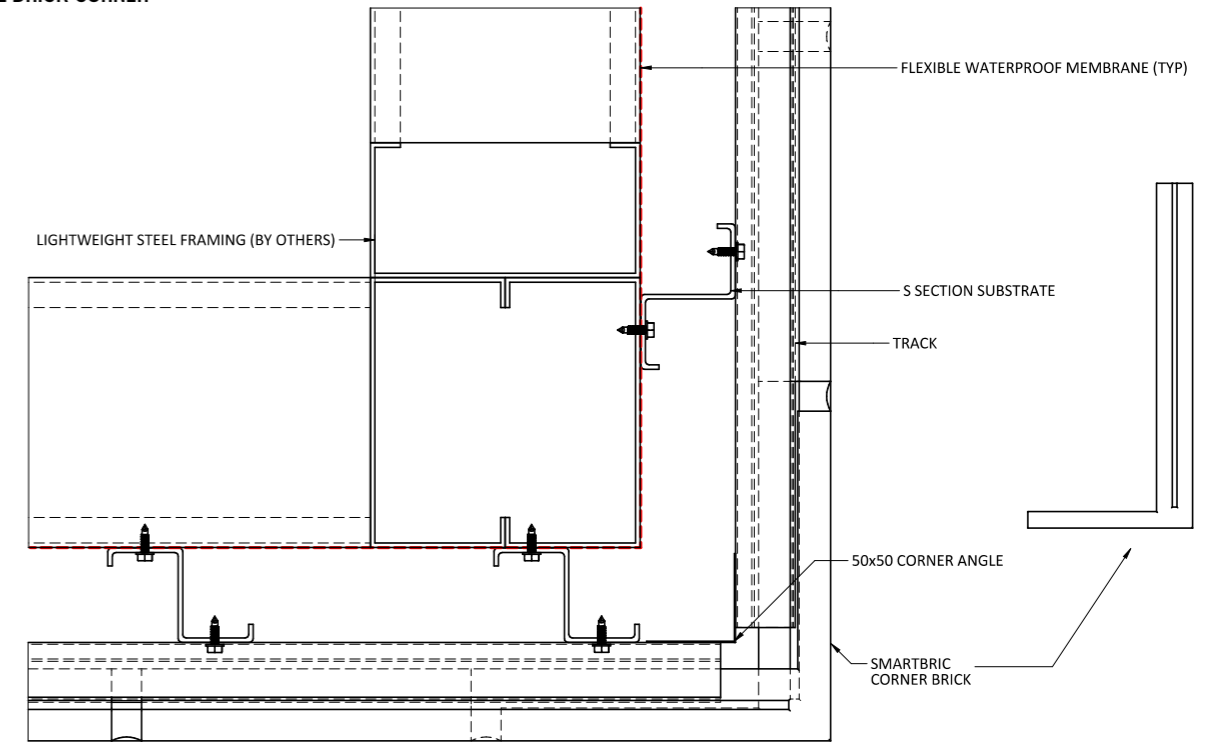

DOOR JAMB DETAIL

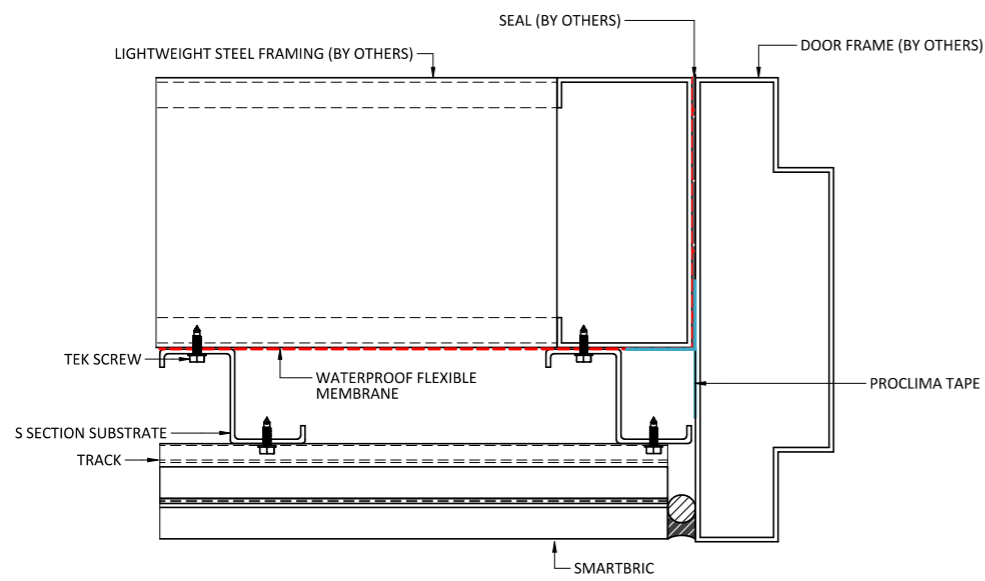

EXTERNAL MITER CORNER

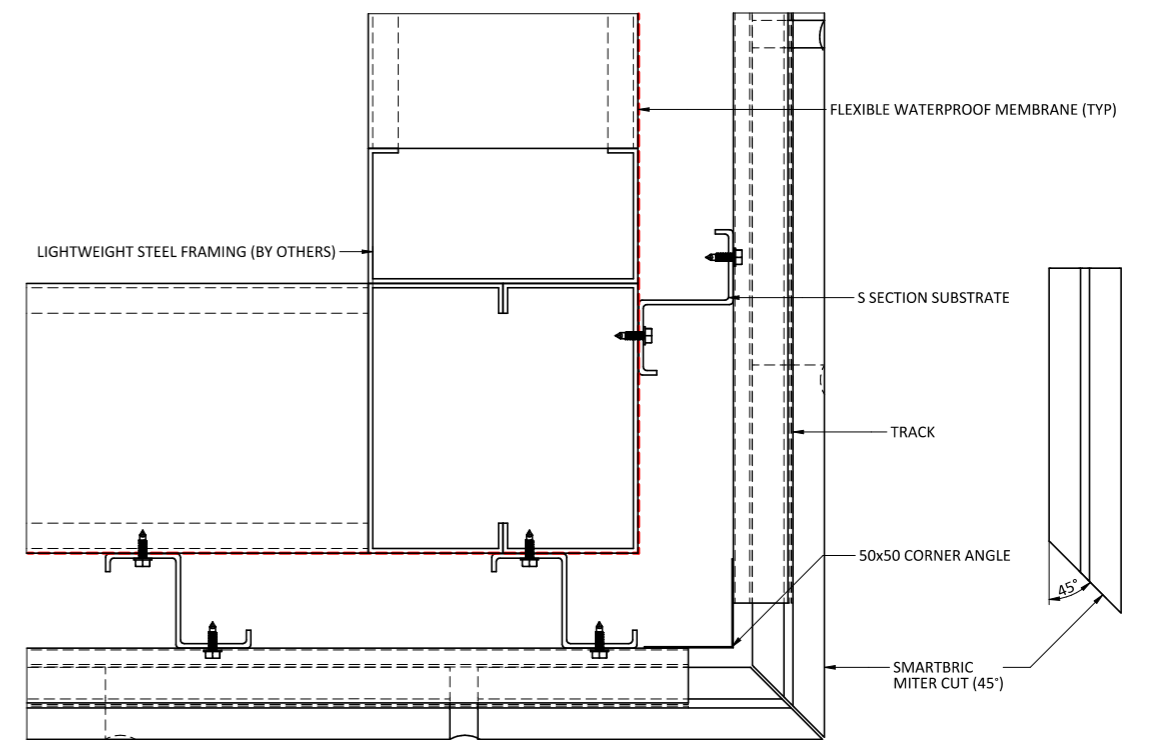

EXTERNAL EXTRUSION CORNER

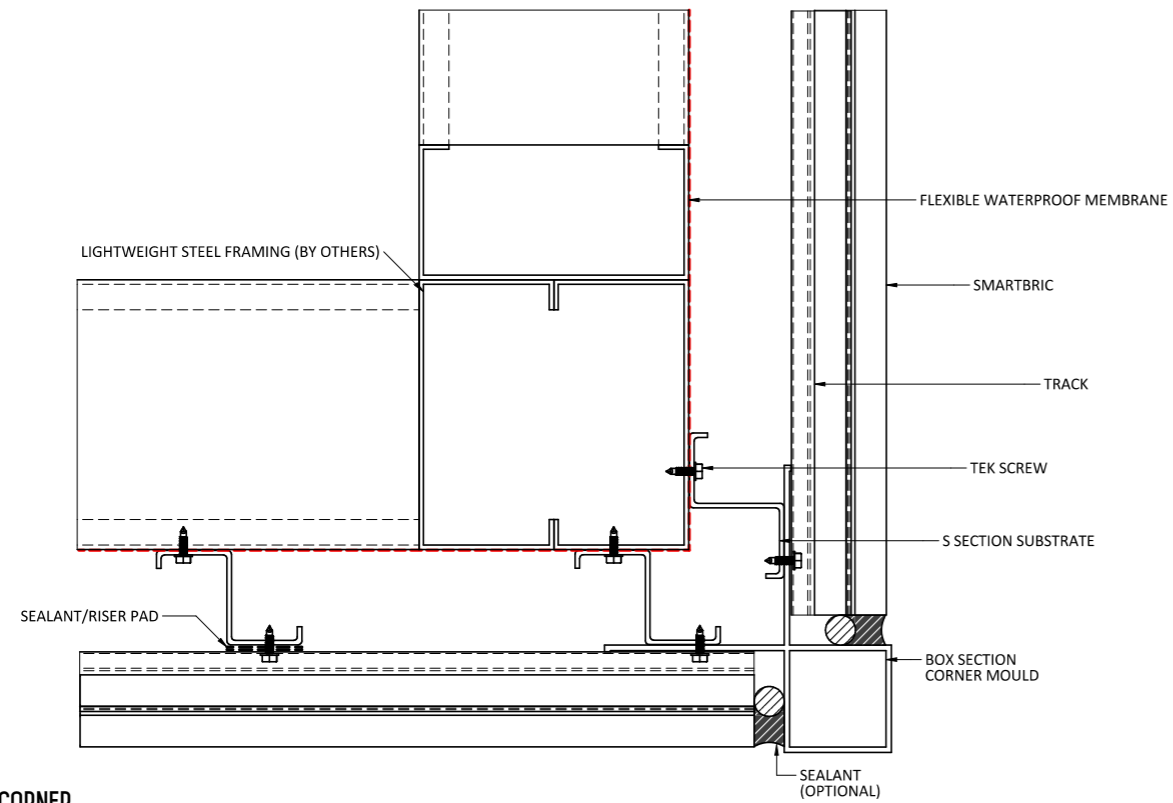

INTERNAL CORNER

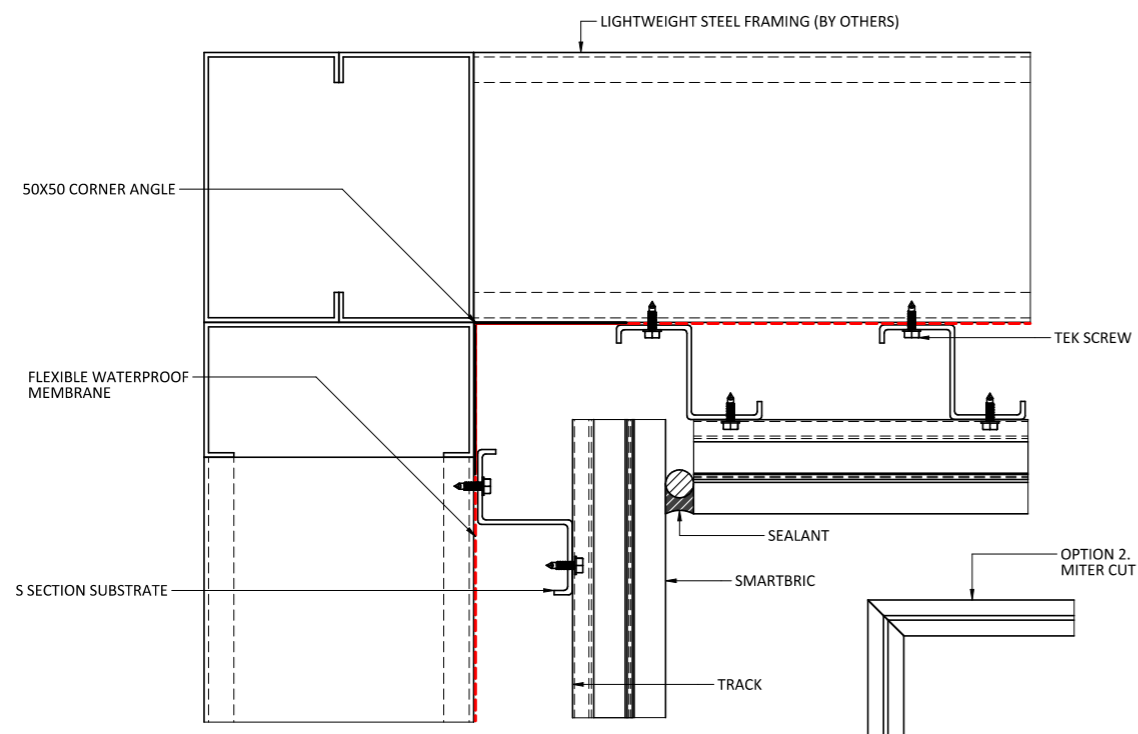

INTERNAL EXTRUSION CORNER

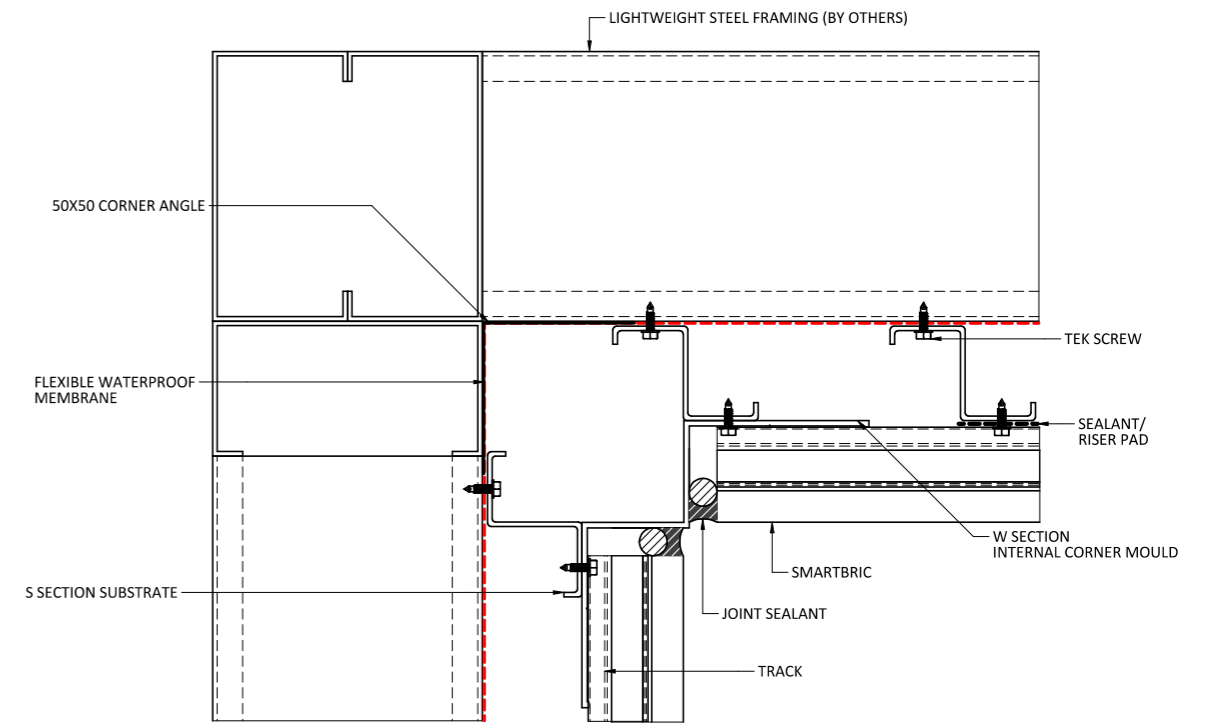

SOFFIT INTERNAL

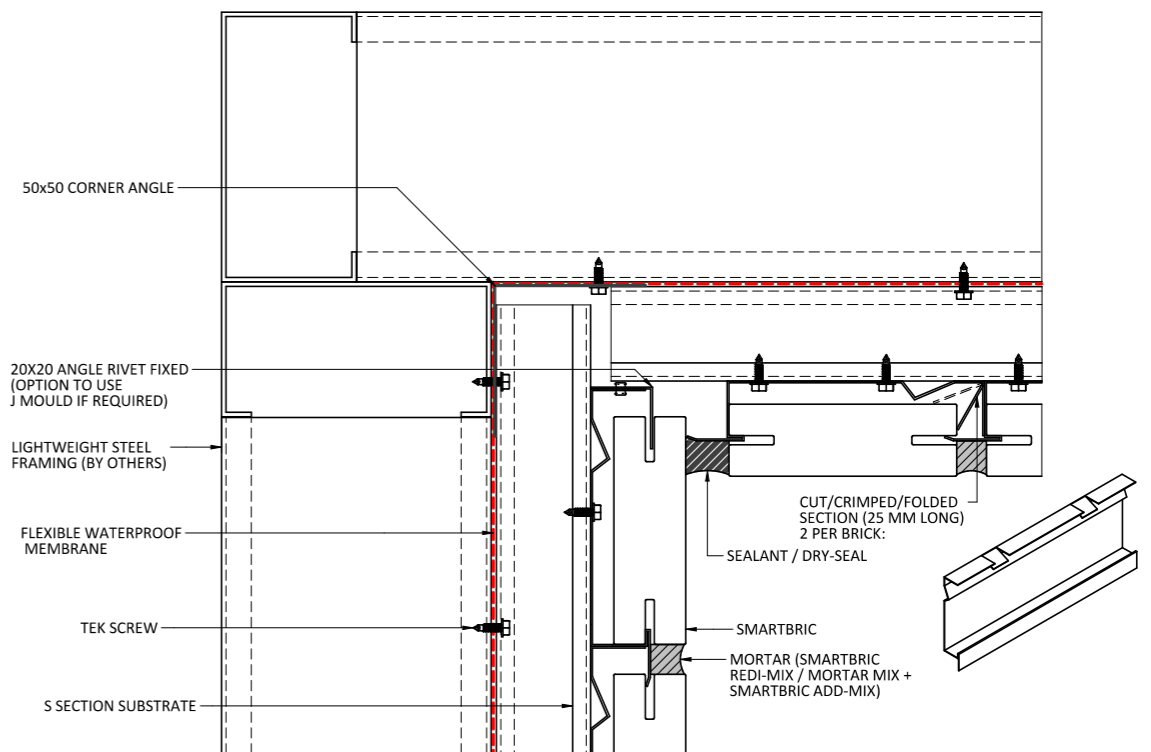

SOFFIT INTERNAL OPTION 2

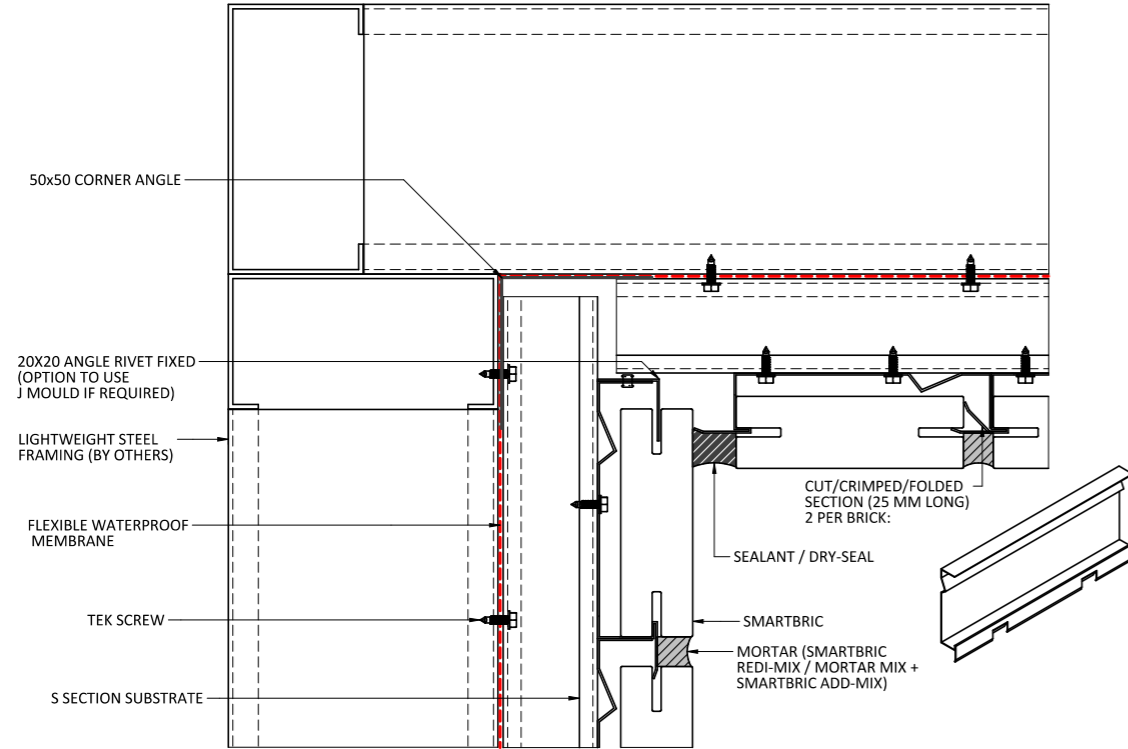

PARAPET DETAIL

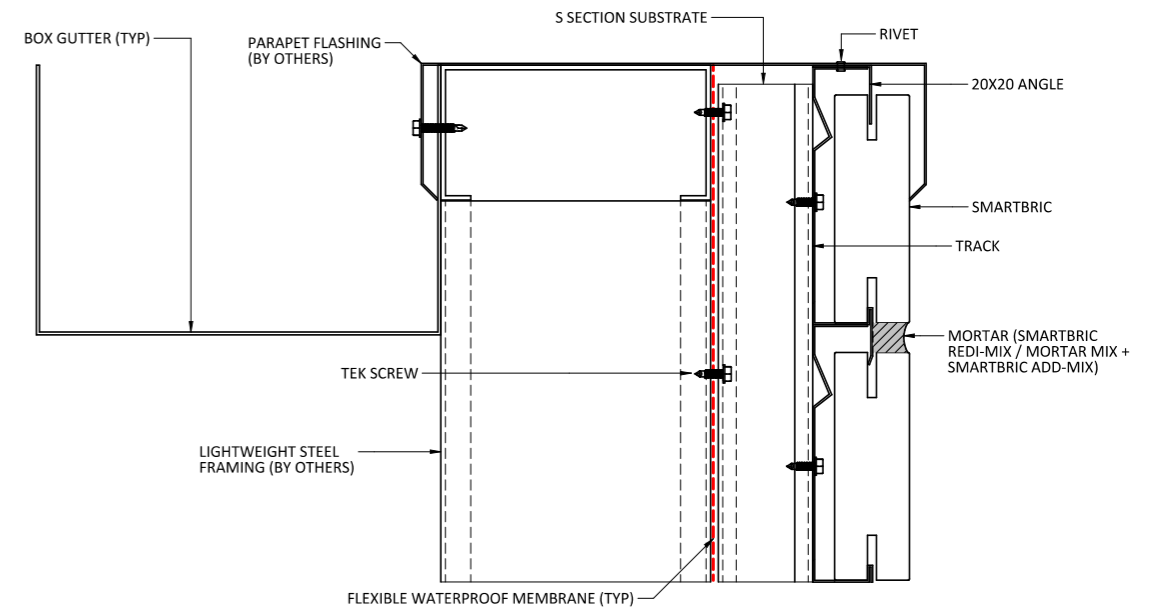

SOFFIT EXTERNAL

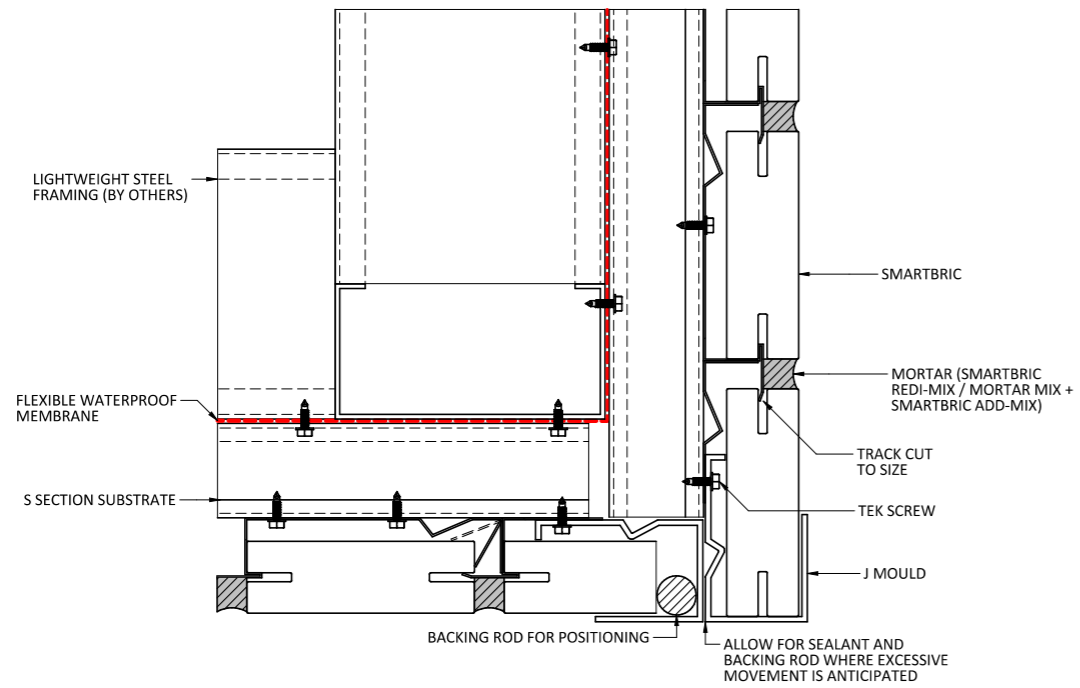

WARRANTY

Smartbric masonry components are incredibly durable materials when used in the right application. Please contact your Fairview representative for full terms and conditions.

MISCELLANEOUS

MAINTENANCE

Inspect condition of the cladding to ensure the integrity and adequacy of the weather resistance for visible signs of problems such as cracking of the brick facing and mortar joints, or rust staining at regular yearly intervals.

Cracked bricks and cracks in the mortar joints are to be repaired to maintain the weather resistance.

External systems are to be maintained and cleaned with potable water at regular 12-month intervals in corrosivity categories C1, C2 and C3. More corrosive environments will require more frequent inspections and cleaning.

MANUFACTURING QUALITY

A dedication to the total fulfillment of our customer's expectations is reflected by a complete quality control system, beginning at the point of specification and continuing through to delivery of the guaranteed products.

All activities are carried out in the manner which:

- Uses the framework of ISO 9001 quality standard to verify the quality of our systems.
- Ensures that our products and services are of the highest standards.
- Creates continuous improvements to our product through the application of the best quality practices.

SUSTAINABILITY

Smartbric has been designed with an expected performance life of over a vast number of years. All Fairview products have been developed with the health of environment and community in mind. As part of our commitment to using recyclable or reusable materials wherever possible, all Smartbric components are 100% recyclable

NOTES



FAIRVIEW™

DEFINING ARCHITECTURE SINCE 1988



AUSTRALIA
NEW ZEALAND
UNITED KINGDOM

SALES ENQUIRIES 1800 007 175

HELPDESK@FV.COM.AU

FV.COM.AU

SMARTBRIC / JANUARY 2024