



FAIRVIEW™

DEFINING ARCHITECTURE SINCE 1963

TRIMS GUIDE

STRYÜM®

NON-COMBUSTIBLE ALUMINIUM FAÇADE / MANUFACTURED BY FAIRVIEW





MAIN PROFILES

DESCRIPTION	CODE	DIAGRAM
Shadow 160	SH160	
Shadow 200	SH200	
Shadow 300	SH300	
Seam 260	SE260	
Step 250	ST250	

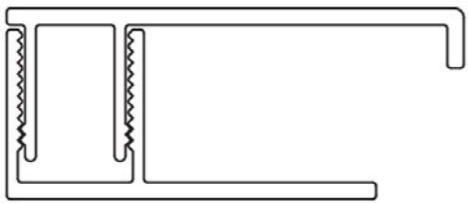
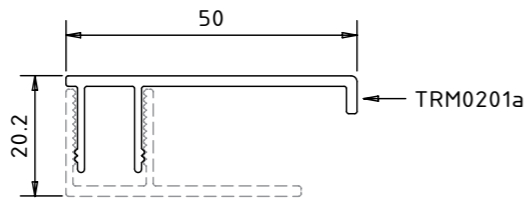
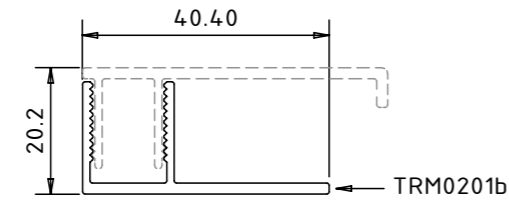
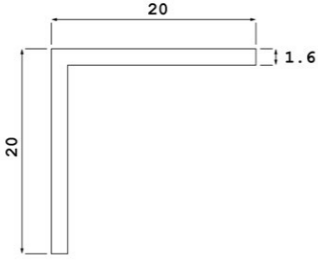
UNIVERSAL TRIMS

DESCRIPTION	CODE	DIAGRAM	USED ON
Stop End (Two-Piece)			All profiles
Stop End Male	TRM0201a		All profiles
Stop End Female	TRM0201b		All profiles
20X20X1.6 Angle	TRM0501		All profiles

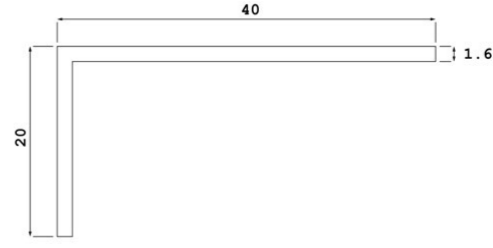
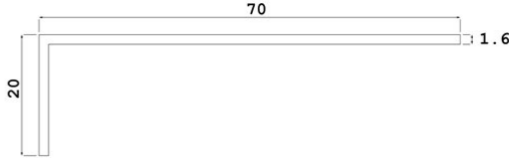
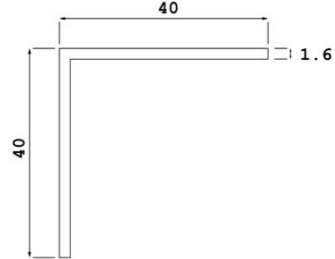

UNIVERSAL TRIMS

DESCRIPTION	CODE	DIAGRAM	USED ON
20X40X1.6 Angle	TRM0502		All profiles
20X70X1.6 Angle	TRM0503		All profiles
40X40X1.6 Angle	TRM0201b		All profiles
40X70X1.6 Angle	TRM0505		All profiles

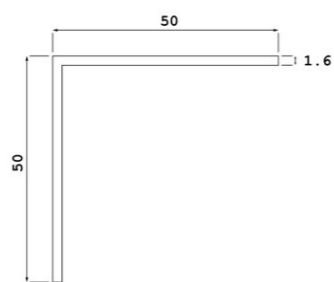
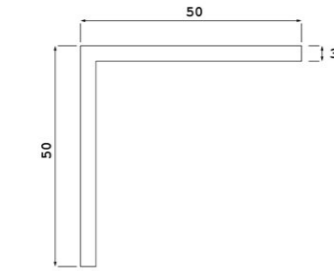
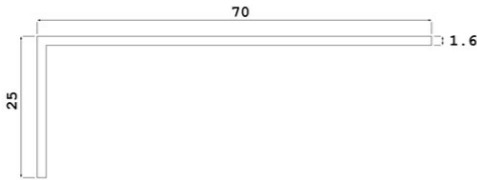
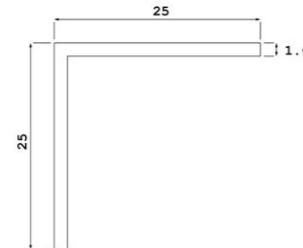
UNIVERSAL TRIMS

DESCRIPTION	CODE	DIAGRAM	USED ON
50X50X1.6 Angle	TRM0506		All profiles
50x50x3 Angle	TRM0507		All profiles
25x70x1.6 Angle	TRM0508		All profiles
25x25x1.6 Angle	TRM0509		All profiles

UNIVERSAL TRIMS

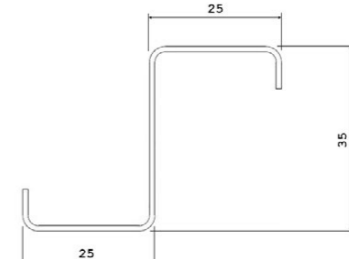
DESCRIPTION	CODE	DIAGRAM	USED ON
25x40x1.6 Angle	TRM0510		All profiles
50x125x3 Angle	TRM0511		All profiles
Stryum S Section	TRM0901		All profiles

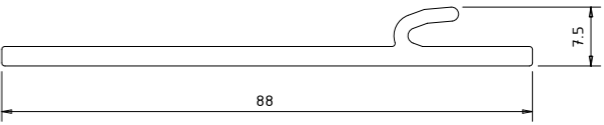
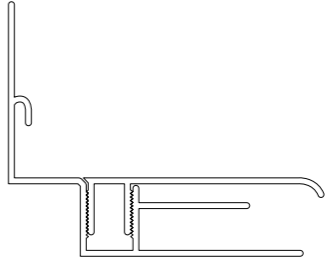
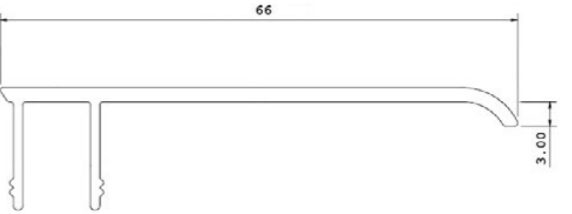
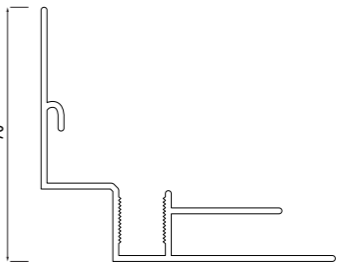

SHADOW TRIMS

DESCRIPTION	CODE	DIAGRAM	USED ON
Shadow Starter Strip	TRM1101		Shadow 160 Shadow 200 Shadow 300
Shadow Vertical Internal Shadowline Corner (Two piece)			Shadow 160 Shadow 200 Shadow 300
Shadow Vertical Internal Shadowline Corner (Male)	TRM1301a		Shadow 160 Shadow 200 Shadow 300
Vertical Internal Shadowline Corner (Female)	TRM1301b		Shadow 160 Shadow 200 Shadow 300

SHADOW TRIMS

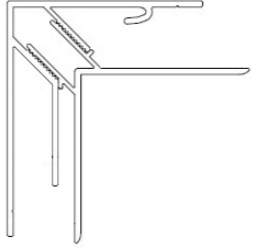
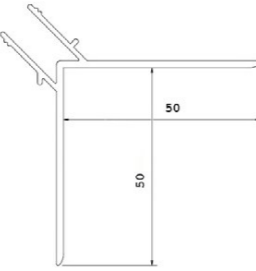
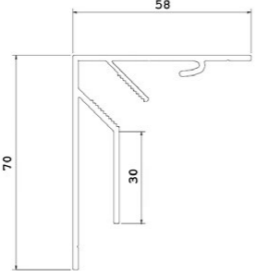
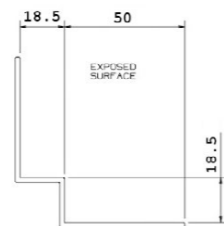
DESCRIPTION	CODE	DIAGRAM	USED ON
Shadow Vertical Internal Cap Corner (Two piece)			Shadow 160 Shadow 200 Shadow 300
Shadow Vertical Internal Cap Corner (Male)	TRM1302a		Shadow 160 Shadow 200 Shadow 300
Shadow Vertical Internal Cap Corner (Female)	TRM1302b		Shadow 160 Shadow 200 Shadow 300
Shadow W Section	TRM1303		Shadow 160 Shadow 200 Shadow 300

SHADOW TRIMS

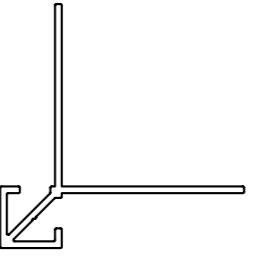
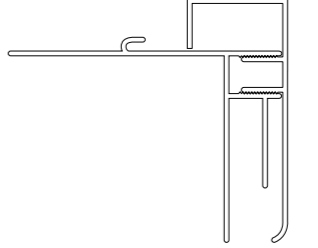
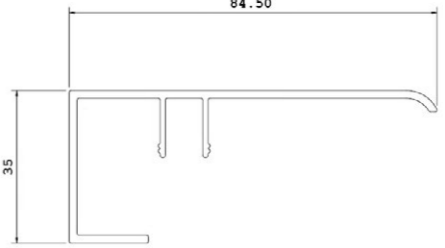
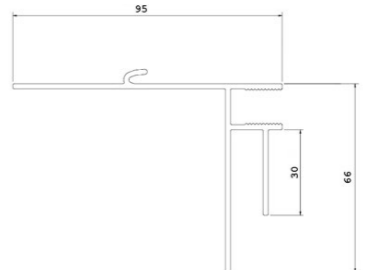
DESCRIPTION	CODE	DIAGRAM	USED ON
Shadow Box External Corner	TRM1401		Shadow 160 Shadow 200 Shadow 300
Shadow Vertical External Shadowline Corner (Two piece)			Shadow 160 Shadow 200 Shadow 300
Shadow Vertical External Shadowline Corner (Male)	TRM1403a		Shadow 160 Shadow 200 Shadow 300
Shadow Vertical External Shadowline Corner (Female)	TRM1301b		Shadow 160 Shadow 200 Shadow 300

SHADOW TRIMS

DESCRIPTION	CODE	DIAGRAM	USED ON
Shadow Vertical External Cover Corner (Two piece)			Shadow 160 Shadow 200 Shadow 300
Shadow Vertical External Cover Corner (Male)	TRM1404a		Shadow 160 Shadow 200 Shadow 300
Shadow Vertical External Cover Corner (Female)	TRM1404b		Shadow 160 Shadow 200 Shadow 300
Shadow X Section	TRM1405		Shadow 160 Shadow 200 Shadow 300

SEAM TRIMS

DESCRIPTION	CODE	DIAGRAM	USED ON
Seam Starter Strip	TRM4101		Seam 260
Seam Foot Mould	TRM4201		Seam 260
Seam W Section	TRM4301		Seam 260
Seam External Corner	TRM4401		Seam 260

STEP TRIMS

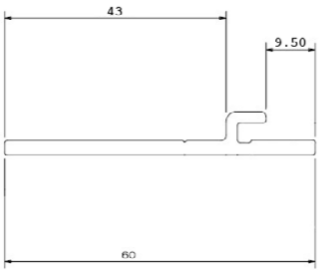
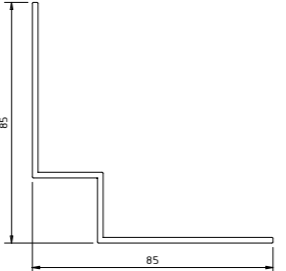
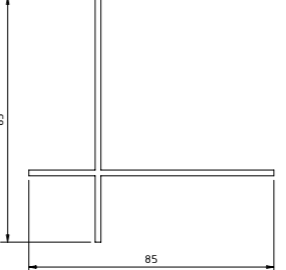
DESCRIPTION	CODE	DIAGRAM	USED ON
Step Starter Strip	TRM5101		Step 250
Step W Section	TRM5301		Step 250
Step X Section	TRM5401		Step 250

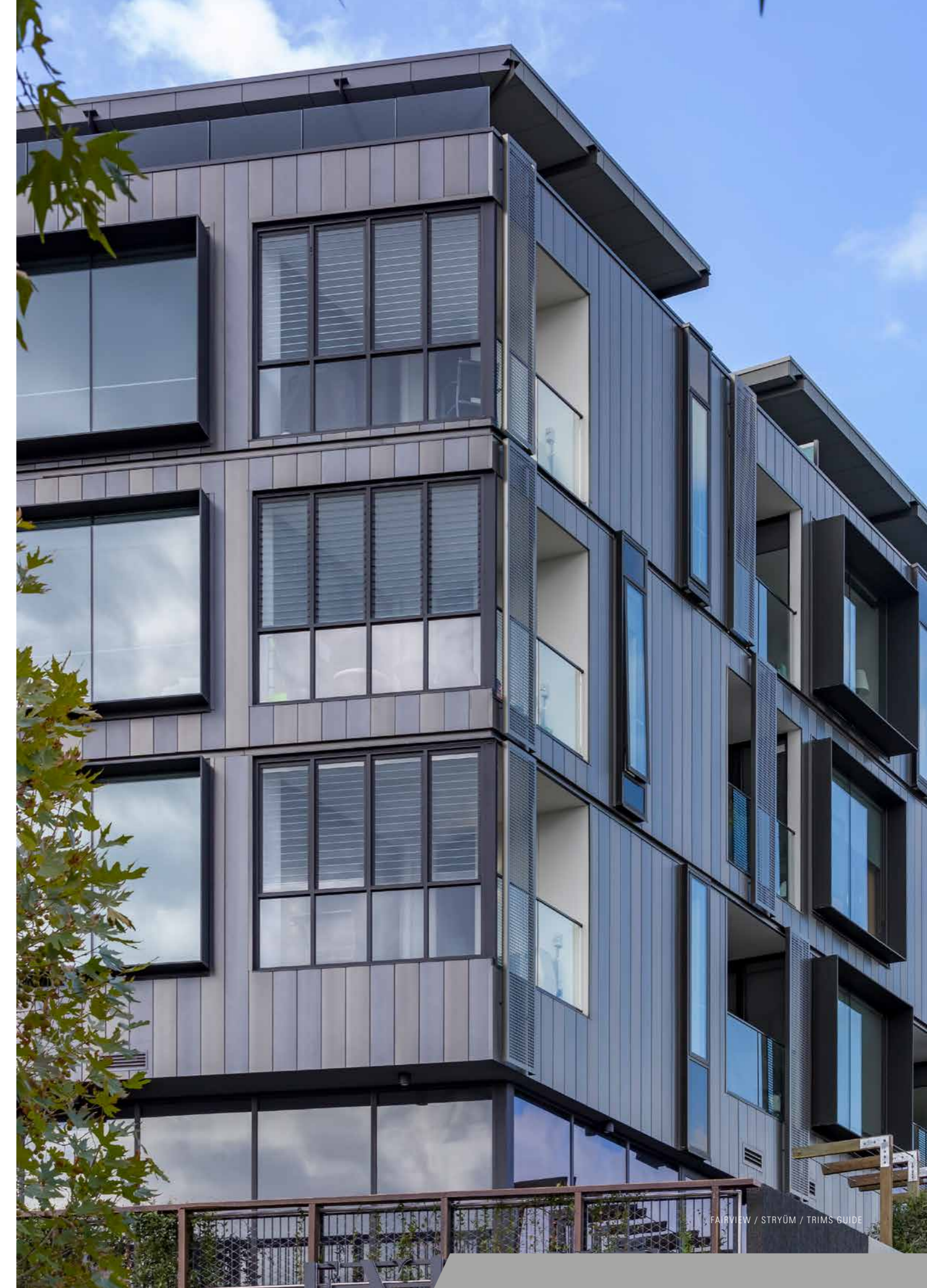



FAIRVIEW™

DEFINING ARCHITECTURE SINCE 1988



AUSTRALIA
NEW ZEALAND
UNITED KINGDOM

SALES ENQUIRIES 1800 007 175

HELPDESK@FV.COM.AU

FV.COM.AU

STRYÛM / OCTOBER 2023