



vitaloc[™]

ROLL-FORMED STEEL CLADDING / BY FAIRVIEW

TECHNICAL INFORMATION

WWW.FV.COM.AU





CONTENTS

- 1. ABOUT THIS GUIDE
- 2. INTRODUCTION
 - 2.1. About Vitraloc
 - 2.2. Key Features
- 3. PANEL SPECIFICATIONS
- 4. COATING SPECIFICATIONS
 - 4.1. Typical coating type
- 5. PERFORMANCE
 - 5.1. Fire
 - 5.2. Weatherproofing
 - 5.3. Thermal expansion
 - 5.4. Oil Canning
 - 5.5. Durability
- 6. INSTALLATION DETAIL
 - 6.1. Installation considerations
 - 6.2. Accessories
- 7. SHADOW VERTICAL & HORIZONTAL
 - 7.1. Installation guide
 - 7.2. General details
- 8. SEAM VERTICAL & HORIZONTAL
 - 8.1. Installation guide
 - 8.2. General details
- 9. FABRICATION DETAIL
 - 9.1. Fabrication considerations
- 10. WARRANTY
 - 10.1. Important warranty information
- 11. MISCELLANEOUS
 - 11.1. Manufacturing quality
 - 11.2. Handling and Storage
 - 11.3. Sustainability
- 12. TECHNICAL DATA SHEET

DOCUMENT TRACKING

VERSION#	DATE	CHANGES
1.0	December 8th 2021	Initial issue

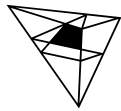

vitaloc™

ROLL-FORMED STEEL CLADDING / BY FAIRVIEW

1. ABOUT THIS GUIDE

This manual has been developed to inform fabricators and contractors with effective installation resource when working with the Fairview cladding system, Vitaloc™.

The guide will provide easy to follow technical information. As uncontrollable conditions of the job scope alter, this guide is a comprehensive resource for users. Fairview recommends seeking the advice of a professional where required prior to installation.

The information and recommendations contained herein are believed to be correct at time of publishing. Fairview reserve the right to revise the contents of this manual.

2. INTRODUCTION

2.1 ABOUT VITRALOC

Vitaloc™ architectural steel cladding makes a visually striking and sophisticated design statement with its distinctive tall sharp ribs and flat smooth pan profiles for that bold and modern architectural look.

Made from non-combustible roll-formed steel, Vitaloc™ provides peace of mind and freedom of expression with an extensive pallet of colours and textures.

Vitaloc™ is part of Fairview's extensive architectural product range and shares a unique DNA with the distinctive Stryüm™ Aluminium Linear wall cladding system.

Vitaloc™ is suitable for both vertical and horizontal applications and is available in two modern profiles – 38mm Seam direct-fix and 25mm Shadow interlocking panels.

Fairview has made product selection simple by offering an extensive range of standardised flashings and two profile options in the 38mm Seam panel with a 265mm cover and 25mm Shadow interlocking panels with a 285mm (plus 15mm express joint) cover. The pan width of the two profiles reflects optimum performance and aesthetic proportions. Custom widths are also available upon request.

Leaving little to chance, Vitaloc™ cladding, with its accompanying flashings and accessories forms part of an engineered and tested system.

2.2 KEY FEATURES

PRODUCT DNA Roll-formed Steel

FINISH Continuous Coil Coated

FIXING SYSTEM Roll-formed interlocking panels taking advantage of a fully detailed system and thermally managed substructure

APPLICATION Type A, B and C construction where non-combustible materials are required such as mixed use developments, residential construction and large-scale government infrastructure projects

WARRANTY 15 year standard warranty, subject to terms and conditions

3. PANEL SPECIFICATION

Vitraloc cladding is manufactured from G300 colour coated steel, aluminium/zinc/magnesium or zinc-aluminium alloy coated steel. Products conform to the following Australian standards that are called up in the National Construction Code (NCC).

STEEL MATERIAL

- All metallic coated steel complies with AS 1397
- Painted steel product conforms with AS 2728

SHADOW 25

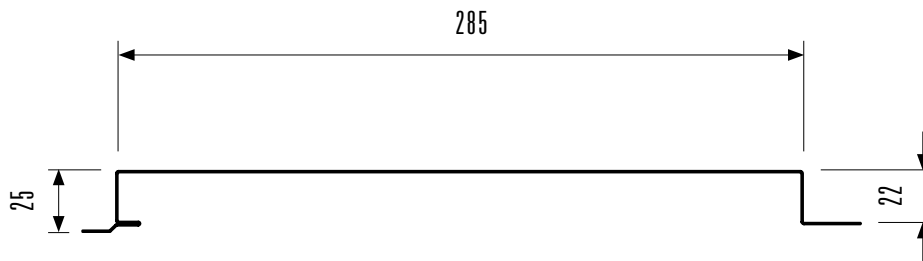

Depth	25mm
Weight	1.08kg/lm
Length	Min: 300mm – Max: 8000mm
Effective cover	300mm (includes 15mm express joint)

SEAM 38

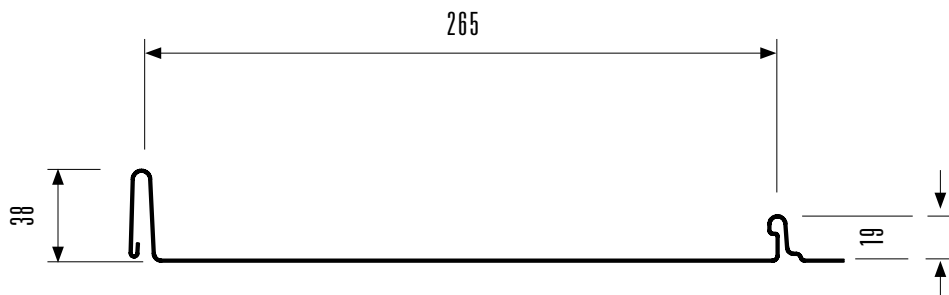

Depth	38mm
Weight	1.08kg/lm
Length	Min: 300mm – Max: 8000mm
Effective cover	265mm

CUSTOM SIZES AND PROFILES AVAILABLE, PLEASE CONSULT YOUR FAIRVIEW REPRESENTATIVE.

4. COATING SPECIFICATIONS

4.1 TYPICAL COATING TYPE

The Vitraloc architectural range of steel cladding profiles are available in an extensive range of classic and contemporary colours, textures, and finishes.

C-MAX™ - COLOUR COATED STEEL AND METALLIC COATED STEEL COIL - SADP/FEA

SUBSTRATE

- Hot-dipped Aluminium/Zinc alloy coated steel coil
- Alloy coating weight 150 g/m²
- Manufactured to AS 1397:2011

SURFACE COATINGS

SADP - SUPER ADVANCED DURABLE POLYESTER COATING SYSTEM

- Nominal film Thickness 18µm ± 2µm. 25% Gloss
- Independently laboratory tested to the requirements of AS/NZS 2728:2013
- Suitable for ISO 9223:2012 and Atmospheric Classifications C1-C3

FEA - FLEXIBLE EXTERIOR ACRYLIC

- Nominal film Thickness 18µm ± 2µm. 25% Gloss
- Independently laboratory tested to the requirements of AS/NZS 2728:2013
- Suitable for ISO 9223:2012 and Atmospheric Classifications C1-C3

C-TEX™ – PREMIUM PATTERNED STEEL AND WOODGRAINS

SUBSTRATE

- Hot-dipped Aluminium/Zinc/Magnesium alloy coated steel coil
- Manufactured to AS 1397:2011

SURFACE COATING

PVDF – CHEMICALLY RESISTANT 70% POLYVINYLIDENE FLUORIDE COATING

- Nominal film Thickness 20µm ± 2µm.
- Independently laboratory tested to the requirements of AS/NZS 2728:2013
- Suitable for ISO 9223:2012 and Atmospheric Classifications C1-C3

5. PERFORMANCE

5.1 FIRE

In today's architectural space the technical details are as important as the overall appearance of the project specification. Architects are seeking products that tick the box for sustainability, moisture control and fire performance.

The demand for specification and deemed non-combustible façades have fast become the industry norm.

As a solid steel pre-finished panel, Vitraloc has been tested to AS 1530.1 and AS 1530.3. All finish types are compliant to NCC 2019 A1 under clause C1.9 e (v).

Vitraloc is a safe preferred choice where deemed non-combustible cladding must be specified for use, application such as hospitals, schools and high-rise buildings.

BASE METAL THICKNESS - BMT (mm)	FINISH	CERTIFICATE NO.	IGNITABILITY INDEX (0-20)	SPREAD OF FLAME INDEX (0-10)	HEAT EVOLVED INDEX (0-10)	SMOKE DEVELOPED INDEX (0-10)
0.55	C-MAX™ (SADP)	CSIRO FNE118094	0	0	0	2
0.55	C-TEX™ (PVDF)	AWTA 19-001730	0	0	0	3

It is important to note that the cladding material is only one component used in the assembly and construction of a system and building elements and other components must also meet the necessary requirements to satisfy the criteria.

5.2 WEATHERPROOFING

Vitraloc wall cladding forms part of an engineered and assembly tested to AS/NZS 4284: Testing of Building Façades and includes proprietary components specifically developed to improve performance and enhance appearance through:

- Moisture management
- Thermal/Heat management
- Movement management

5.3 THERMAL EXPANSION

All metal sheeting is subject to thermal expansion and, where there is a temperature difference between the sheeting and the structure, this needs to be accommodated.

The colour of the sheeting will affect the amount of thermal expansion

MATERIAL	ELONGATION PER 1000mm $\Delta T = 50^{\circ}C$
Vitraloc	0.6mm

To minimising the effects of oil-canning, it is recommended to keep panel lengths under 9m.

Sheet lengths greater than 15m are not recommended due to thermal expansion and contraction.

Vitraloc cladding is typically available in lengths up to 3 metres, with lengths up to 8m being standard. Longer lengths may be available however these are not standard. Besides thermal engineering considerations, handling and transportation restrictions also apply to long lengths. Special delivery requirements apply to lengths over 6 metres.

5.4 OIL-CANNING

“Oil-canning” is a perceived waviness or distortion light gauge, cold formed cladding material. Wide, flat profiles may be subject to or more predisposed to oil-canning, however this is usually an aesthetic issue only and the structural performance and weatherproofing is not affected.

Vitraloc is deliberately offered in two modern profiles – 38mm Seam panel with a 265mm cover and 25mm Shadow interlocking panels with a 285mm cover to minimise the appearance of oil-canning through the use of narrower width profiles.

Oil-canning can further be reduced by use of lighter colours in matt finishes and ensure the sub structure is in a flat plane and fasteners are installed correctly.

Fairview has developed a Patented (Pending) Solution for the management of oil-canning using a strip-rod device and proprietary batten arrangement. This innovative solution allows the sub-structure to accommodate movement and alleviate cladding distortion.

With careful attention to the production, panel design and installation practice, oil-canning can be effectively minimised but cannot realistically be totally eliminated. Where appearance is critical to the design, Fairview’s Stryüm product line may provide an aesthetic solution to oil-canning.

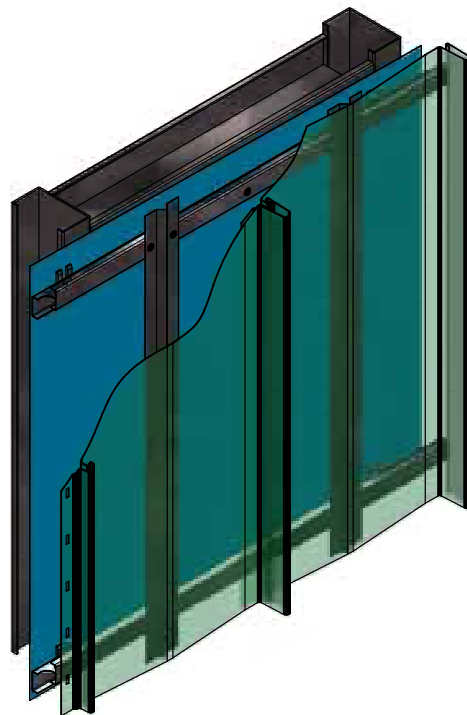

5.5 DURABILITY

C-MAX™ and C-TEX™, under normal well washed conditions of exposure, can be expected to show no cracking (other than that which may occur during forming), flaking or peeling of the paint film for 20 years from the date of installation. Colour change during service will depend on the colour chosen, aspect, design of the structure and the environment. Some chalking may occur. A maximum rating of 2 is expected after 20 years exposure, when measured in accordance with AS/NZS1580.481.1.11:1998. Scale is between 0 and 5 with a lower number indicating less chalking. The above are subject to minimum maintenance requirements.

ENVIRONMENTAL USAGE GUIDE

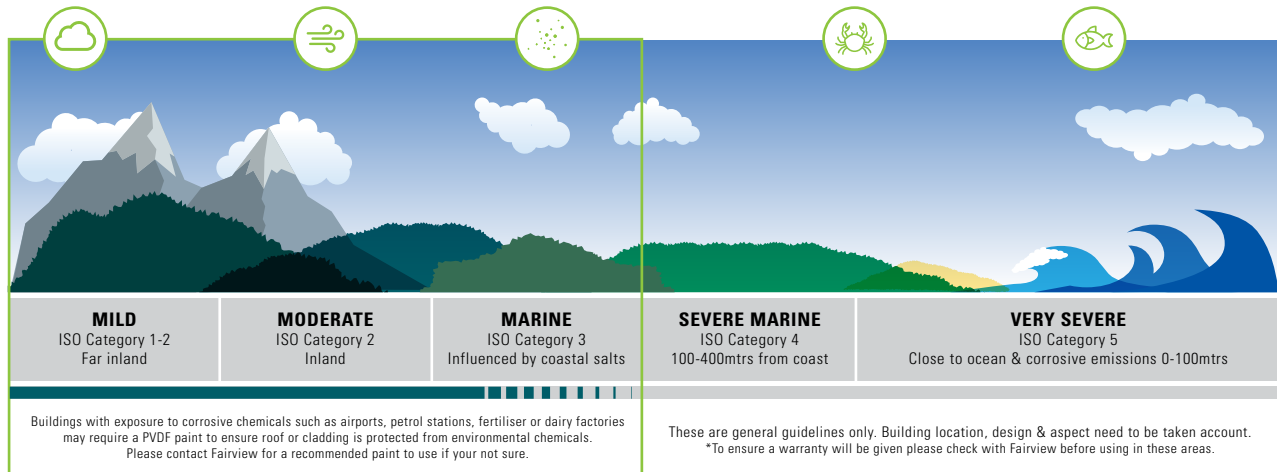

Fairview offers warranties of differing lengths on C-MAX™ & C-TEX® for residential, commercial and industrial buildings in ISO 1-3 environments, depending on whether the product will be used for cladding or roofing.

Wall cladding* Fascia*	Paint	15yrs
	Perforation	15yrs

* Refer to specific warranty information for full terms and conditions, including exclusions and minimum maintenance requirements. Buildings close to industrial areas which are exposed to corrosive chemicals may require PVDF for added protection.

6. INSTALLATION DETAIL

6.1 INSTALLATION CONSIDERATIONS

Fairview recommends that good trade practice be followed when using this product, such as that found in Australian Standards Handbook HB39.

- Sheeting and flashing must be installed by a skilled tradesperson if quality results are to be achieved. This is particularly so for details such as door and window corners and flashing that have exposed fastenings. Careful design of flashing details to suit the application can help to ensure reliable function and quality finish.
- As minor colour variation can occur between production lots, it is recommended that the total material requirements for the project are placed in one order to ensure colour consistency.
- Where steel may meet dissimilar metals, a proper insulator or caulking tape should be applied to insulate between dissimilar materials to avoid corrosive electrolytic action.
- Ensure Vitraloc is used as part of a compliant wall system, complying with deemed-to-satisfy provisions of the relevant NCC or approved as part of a performance solution.
- Vitraloc panels will be installed with uncoated edges. These panels are treated to be resistant to corrosion and within a minute of cutting the panel, a microscopic oxide layer will have formed over the cut edge preventing any further corrosion outside of extreme conditions.
- If installed as per the installation requirements, these edges are adequately drained and ventilated to prevent sitting in pooled water. If the panels are installed incorrectly so that they are subject to pooled water, this may eventually allow for corrosion.
- When installing Vitraloc, ensure that the panel has fully locked together before fixing the panel with screws.
- Due to the interlocking nature of Vitraloc, it is critical that special attention is paid to installing the perforated S section substructure correctly. It must provide a flat surface for the cladding to be installed on, as any inconsistencies in the substructure may affect the visual appearance of the cladding.
- Vitraloc panels utilise protective films which must be removed immediately upon product installation. Prolonged UV exposure will make removal difficult. The film must be removed from laps and difficult to access areas prior to final fixing in place. Strippable film must not remain in direct sunlight for more than half a day.

6.2 ACCESSORIES

All standard components are available from Fairview. Please visit the Vitraloc Flashings Guide for further information.

STANDARD RANGE OF FLASHINGS

Vitraloc offers an extensive range of flashings that have been specifically designed to be universally popular and suitable for most applications.

While each flashing design may be different, to suit different wall sheeting profiles and particular applications, there are elements common to each. Minor variations may exist from that shown.

For further information, refer to the Vitraloc Flashing Guide.

STANDARD CLADDING PROFILES - SPECIALS

Vitraloc cladding can also be supplied with customised folded sheets to enhance aesthetics and deliver design refinement.

VITRALOC SEAM 38



TOP FOLD - FOLD BACK

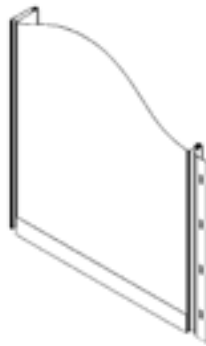

BOTTOM HOOK FOLD

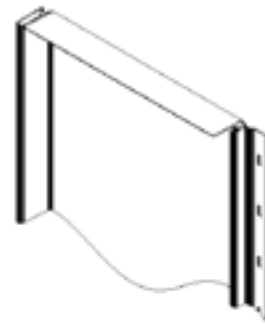

TOP FOLD - STOP END 38

VITRALOC SHADOW 25



TOP FOLD - STOP END

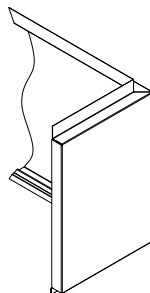

END FOLD - STOP END

CUSTOM ROLLED FLASHING

Vitraloc cladding sheets up to 6 metres can be folded to form custom flashings. Flashings must be detailed and dimensioned by the designer or installer for each specific job.



FASTENERS

All fastening screws must conform to AS3566 - Class 3*. Vitraloc cladding is to be fixed with the required number of fasteners per sheet at each batten/purlin to meet the required performance values.

At each supporting member, fix sheets through the centre of an appropriate slot of the underlap which coincides with the supporting member.

Over-driven fasteners can distort and create stresses in the panel.

For the screw to be properly tightened into metal there should be a minimum of three (3) threads protruding past the support being fixed in to.

SUPPORT	FASTENER TYPE
Steel 35mm x 1mm S-Section Perforated Batten	10G-16 x 16mm wafer head Tek screw 
	Buildex Climaseal 3 10-16 x 16mm Smooth Top Plain 
Metal Batten to Frame	12G-14 Hex Metal Self Drilling Tek screw 

VITRALOC ARCHITECTURAL DETAILING GUIDE

This guide presents alternate methods of detailing and finishing metal-clad walls. Solutions provided are typical only. Many real applications will require the adaptation of the ideas shown, or the development of unique solutions using the principles set out in the guide.

In some instances, flashing is best when invisible, and there are other cases where making a feature of flashing can enhance appearance. Renditions of some key aesthetic differences between alternatives have been included to show choices. In addition, commentary is made on aspects such as potential distortion around fixings. Important functional considerations have also been addressed where applicable.

*NB Class 4 needed in coastal areas.

7. SHADOW VERTICAL & HORIZONTAL

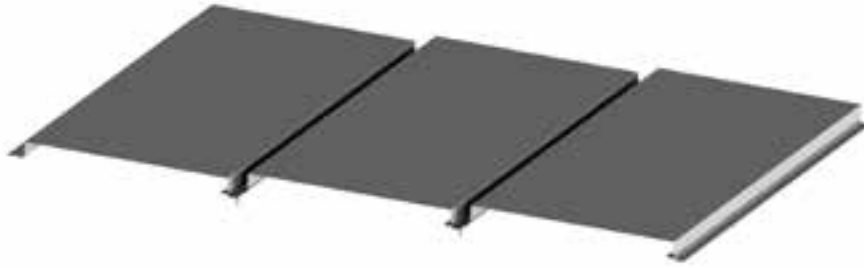

7.1 INSTALLATION GUIDE

STANDARD ENGAGEMENT PROCEDURE – VITRALOC SHADOW 25

Vitraloc Shadow 25 can be installed in both vertical and horizontal orientations using the same basic procedure.

Fixing battens for vertical and horizontal panels should be spaced at 600mm maximum centres. Closer batten spacing provide a more rigid assembly resulting in less deflection and distortion (oil-canning). Generally, 450mm spacing is recommended.

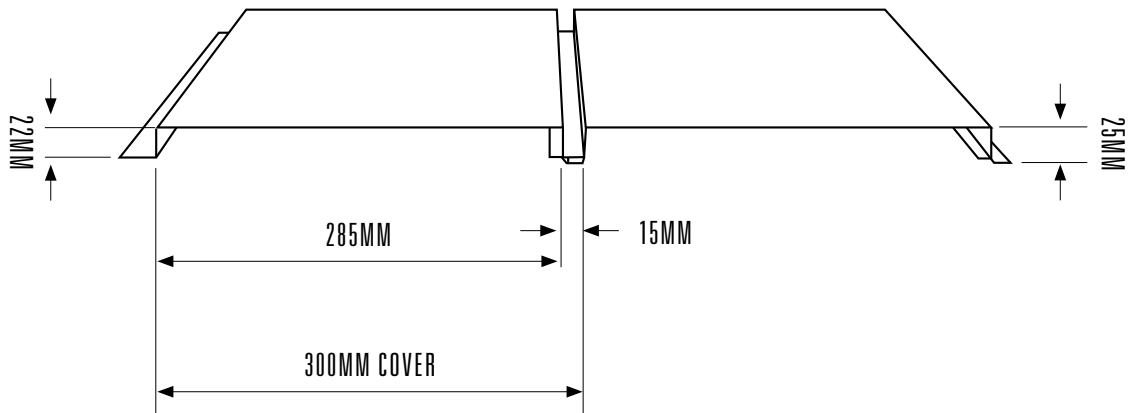

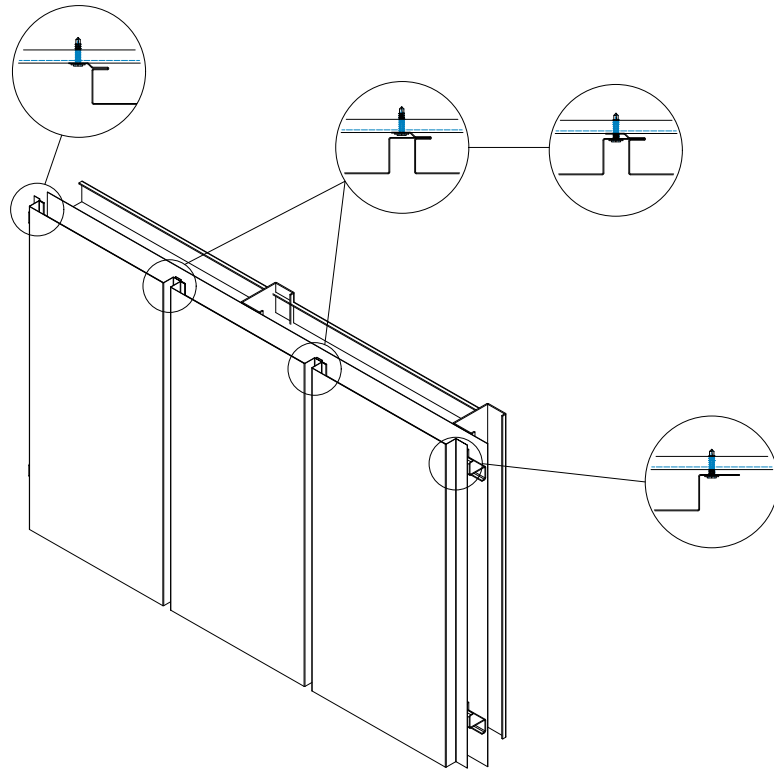

When installing horizontally, general consideration is given to good practice and proper drainage, hence it is desirable to install the cladding sheet with the under-lock tab facing downwards. To facilitate this, cladding sheets can be installed from top to bottom. This technique also allows for the fixing fastener to be concealed.

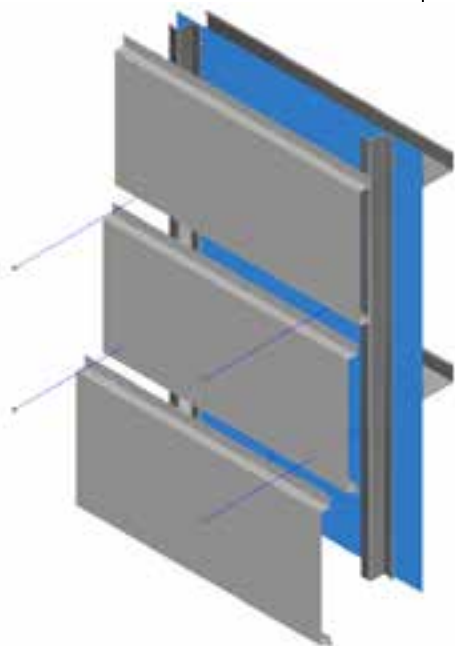
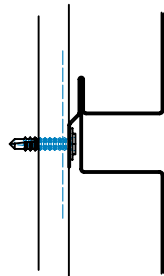

The alternate technique of installing from the bottom up will result in either poor drainage detail or having to fasten the fixing through the express joint which exposes the fastener screw and results in restricting movement of the cladding, which are generally considered undesirable and not recommended.

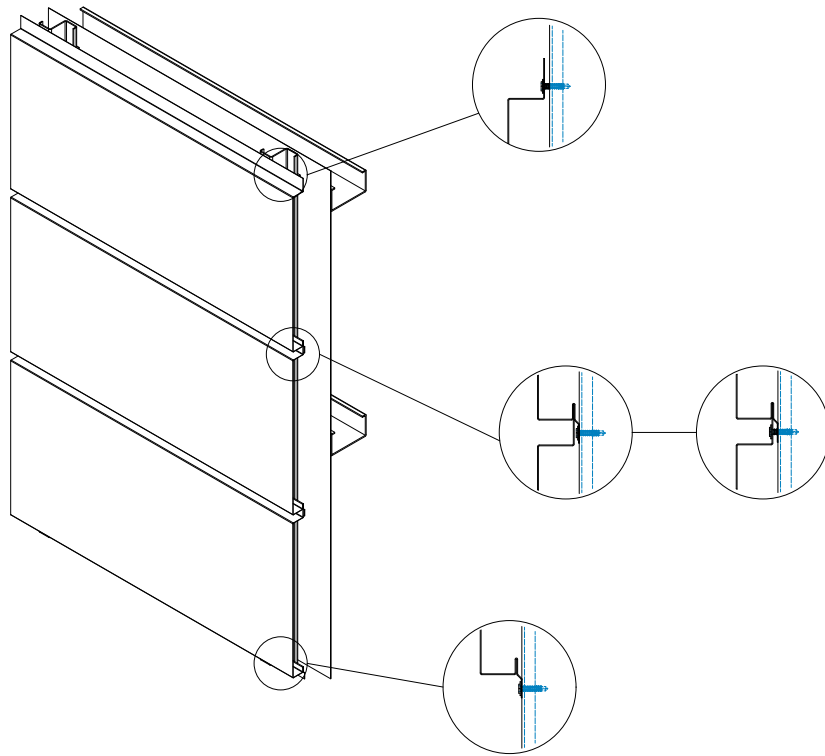

7.2 GENERAL DETAILS - SIDE ELEVATION

FIXING - AS SPECIFIED
 WAFER HEAD SCREW /
 PANEL RIVET / TEK SCREW

UA50X25-CCRUSH
 FOLD ANGLE

TH24-50
 tophat

285 -25
 VITRALOC™ SHADOW

NOTE: JOIN TO TOP

Z SECTION SUBSTRATE

FLEXIBLE
 MEMBRANE (TYP)

STEEL STUD WALL
 FRAMING (TYP)

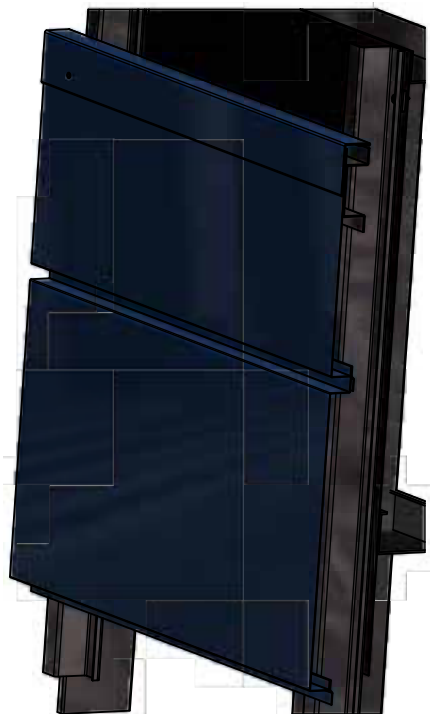

SHADOW VERTICAL PANEL CONNECTION DETAIL - PLAN

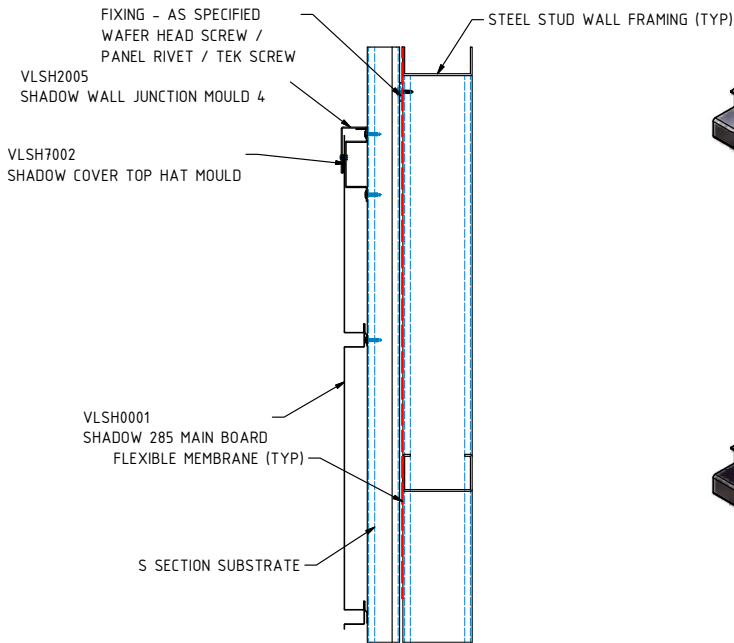

PANEL CONNECTION B

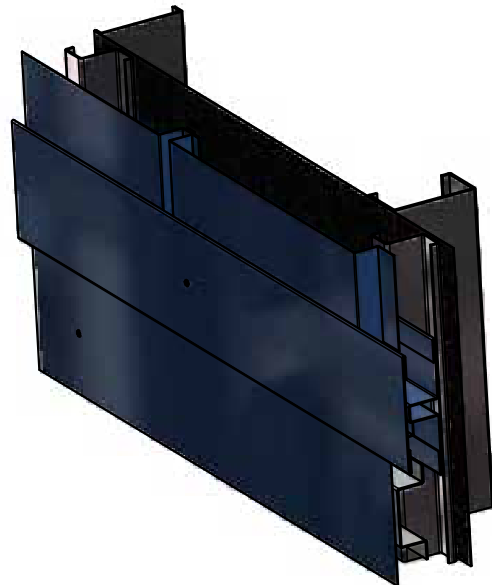
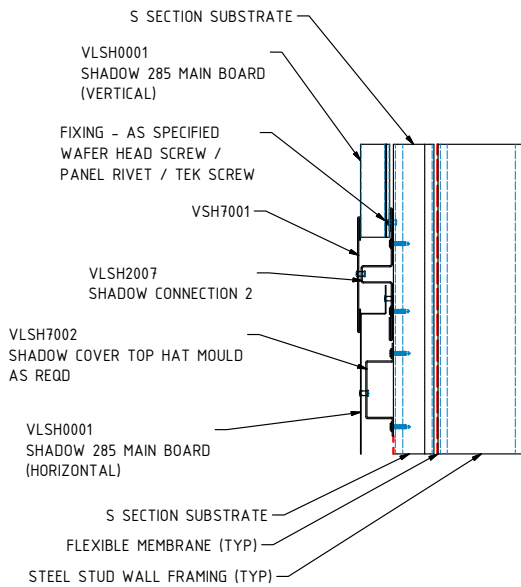

DISCLAIMER: THESE DETAILS ARE LIMITED TO THE GENERALISED DESIGN SPECIFICATION FOR FAIRVIEW VITRALOC, AND ARE INTENDED FOR USE BY A TECHNICALLY SKILLED PERSON ONLY. ANY USE OF THE SAME IS AT THEIR OWN DISCRETION AND RISK. © FVA GROUP PTY. LTD.

WALL JUNCTION A1

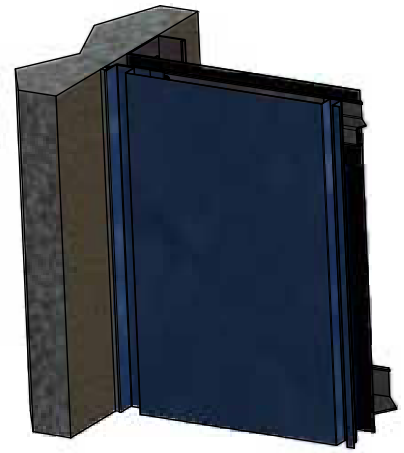
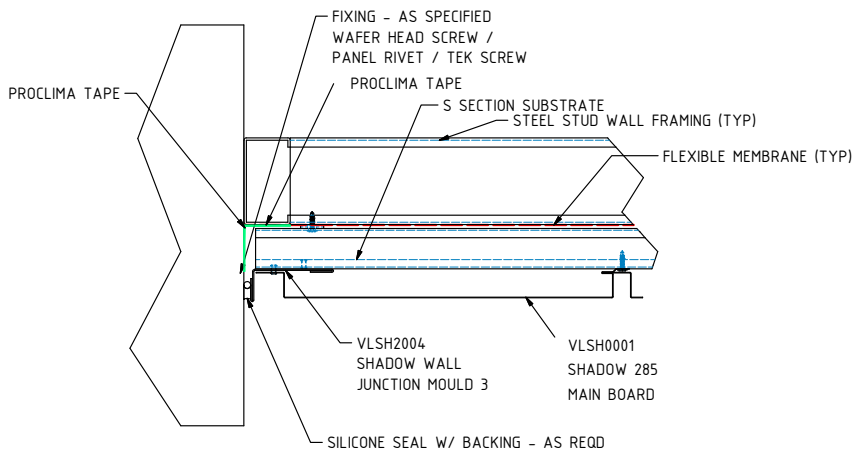

WALL JUNCTION A2

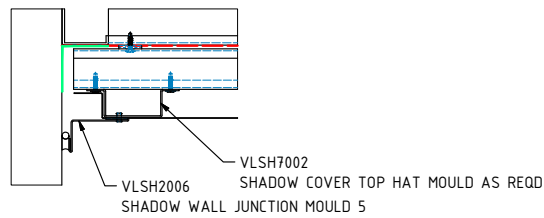

WALL JUNCTION B1

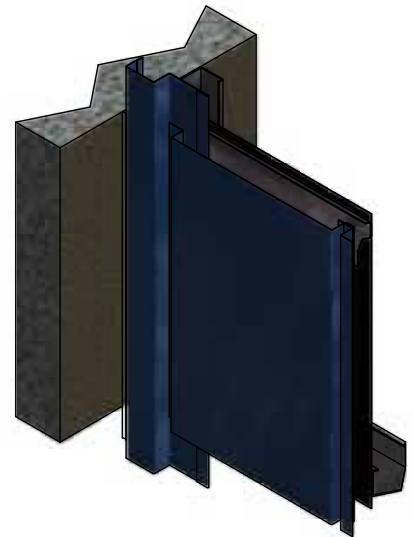
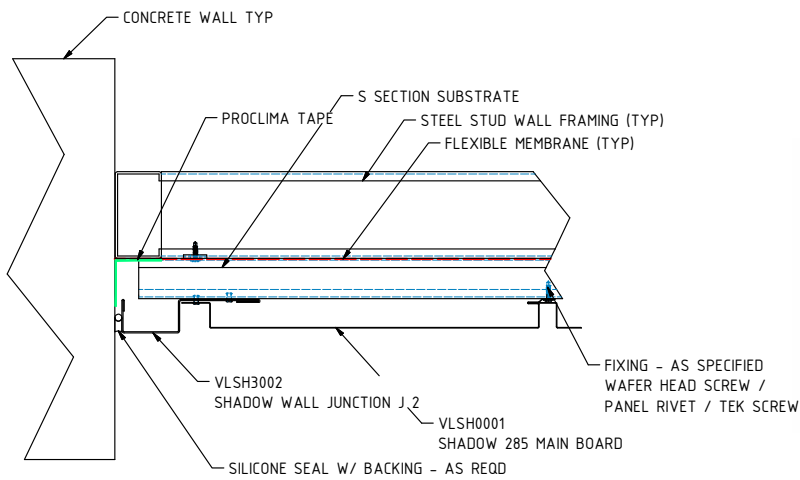

WALL JUNCTION B2

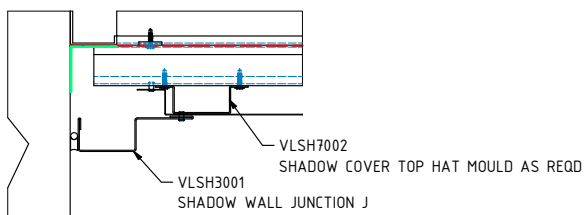

DISCLAIMER: THESE DETAILS ARE LIMITED TO THE GENERALISED DESIGN SPECIFICATION FOR FAIRVIEW VITRALOC, AND ARE INTENDED FOR USE BY A TECHNICALLY SKILLED PERSON ONLY. ANY USE OF THE SAME IS AT THEIR OWN DISCRETION AND RISK. © FVA GROUP PTY. LTD.

WALL JUNCTION C

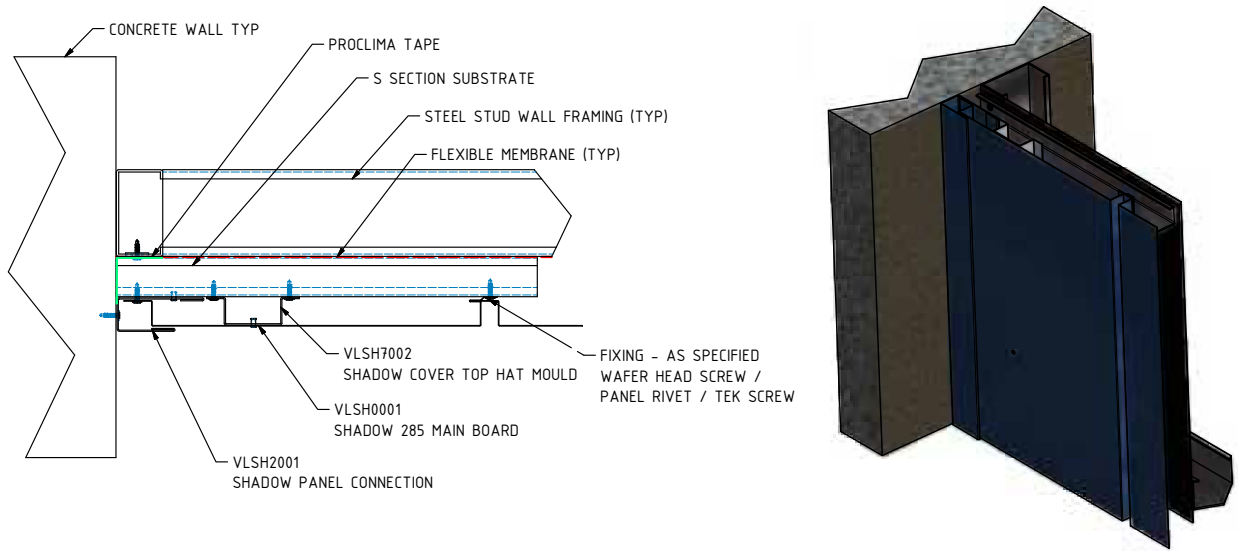

INTERNAL CORNER DETAIL

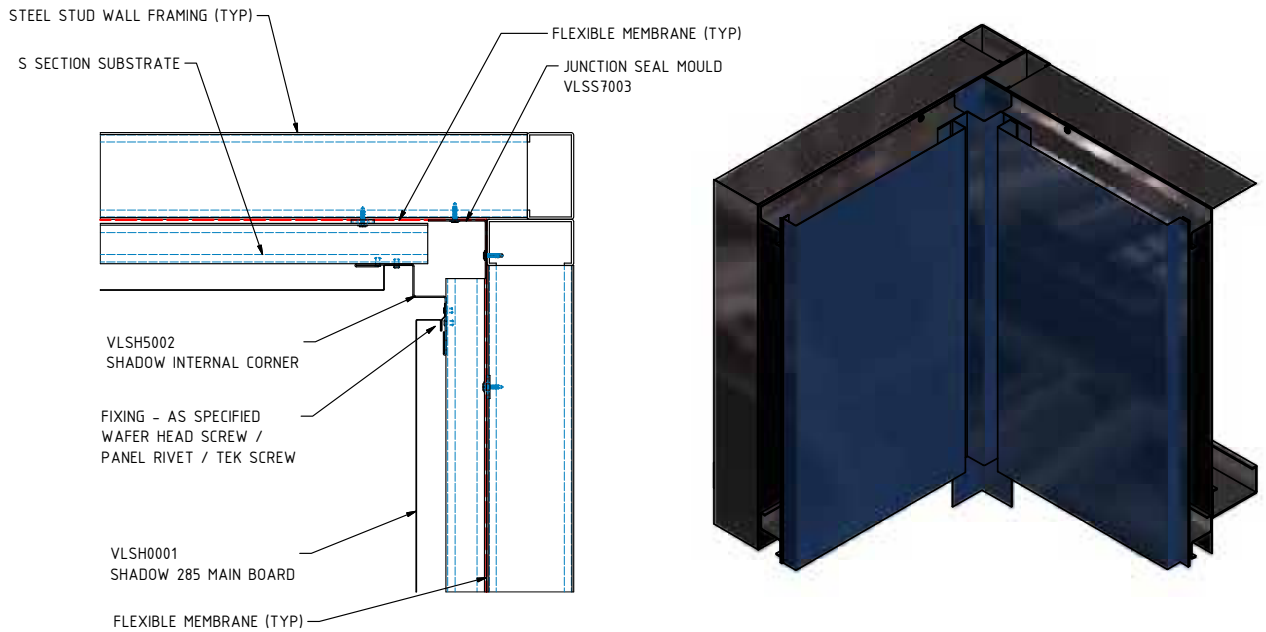

DISCLAIMER: THESE DETAILS ARE LIMITED TO THE GENERALISED DESIGN SPECIFICATION FOR FAIRVIEW VITRALOC, AND ARE INTENDED FOR USE BY A TECHNICALLY SKILLED PERSON ONLY. ANY USE OF THE SAME IS AT THEIR OWN DISCRETION AND RISK. © FVA GROUP PTY. LTD.

INTERNAL CORNER B

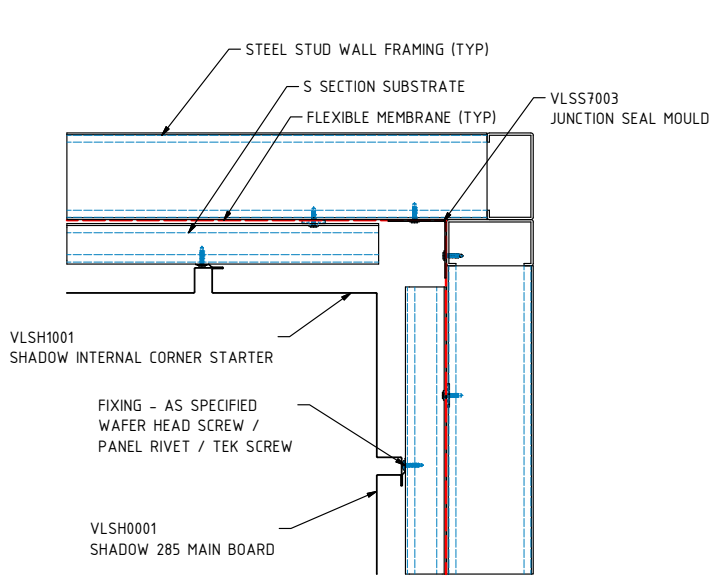

EXTERNAL CORNER DETAIL A

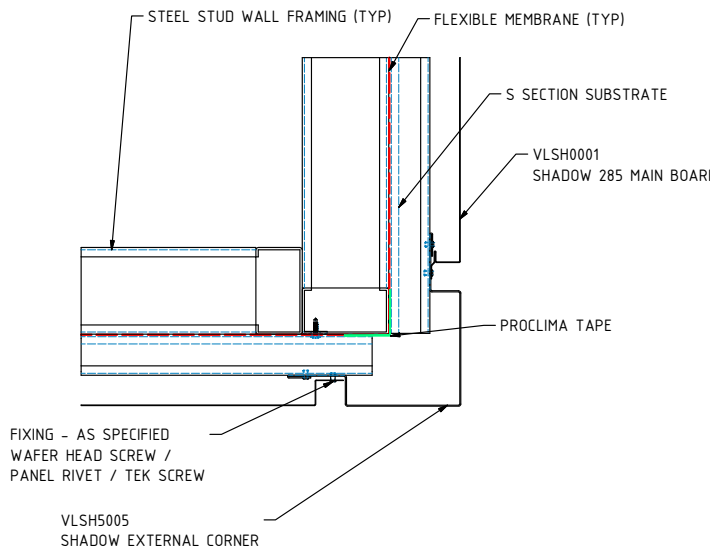

DISCLAIMER: THESE DETAILS ARE LIMITED TO THE GENERALISED DESIGN SPECIFICATION FOR FAIRVIEW VITRALOC, AND ARE INTENDED FOR USE BY A TECHNICALLY SKILLED PERSON ONLY. ANY USE OF THE SAME IS AT THEIR OWN DISCRETION AND RISK. © FVA GROUP PTY. LTD.

EXTERNAL CORNER DETAIL B

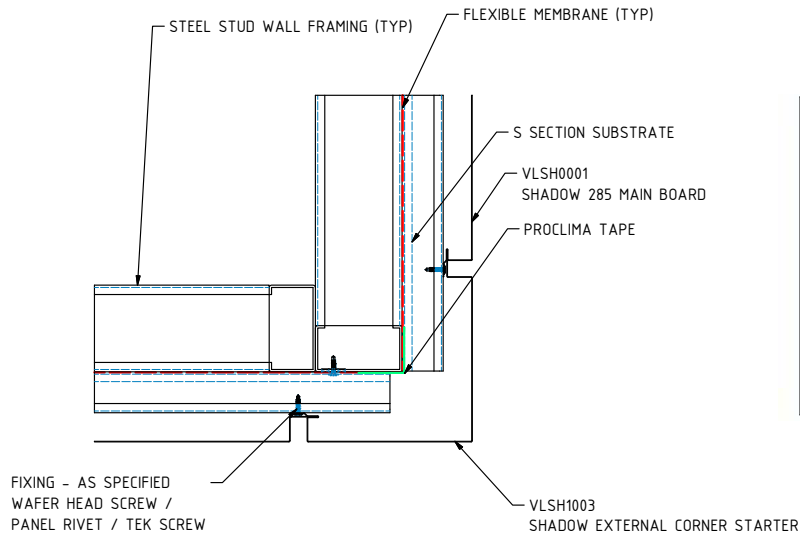

EXTERNAL CORNER DETAIL C

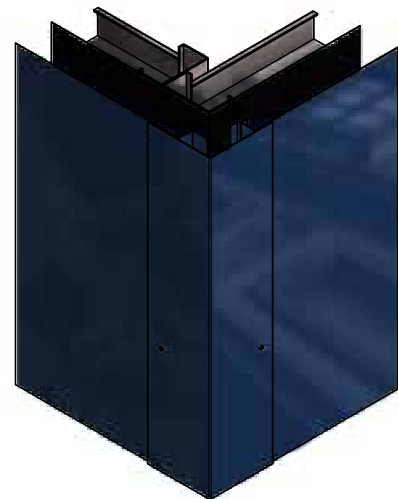
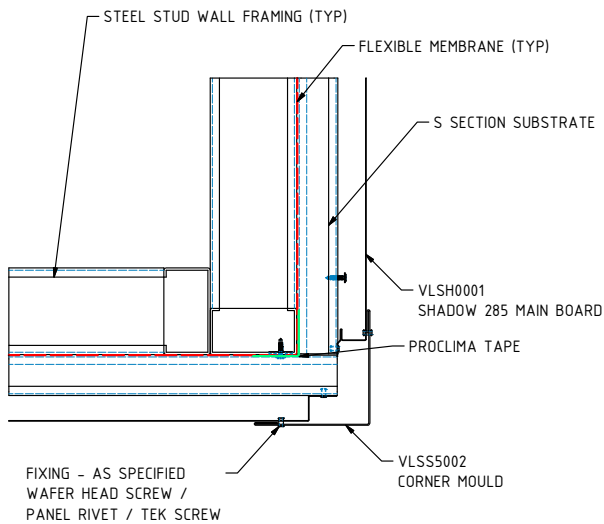

DISCLAIMER: THESE DETAILS ARE LIMITED TO THE GENERALISED DESIGN SPECIFICATION FOR FAIRVIEW VITRALOC, AND ARE INTENDED FOR USE BY A TECHNICALLY SKILLED PERSON ONLY. ANY USE OF THE SAME IS AT THEIR OWN DISCRETION AND RISK. © FVA GROUP PTY. LTD.

WINDOW HEAD

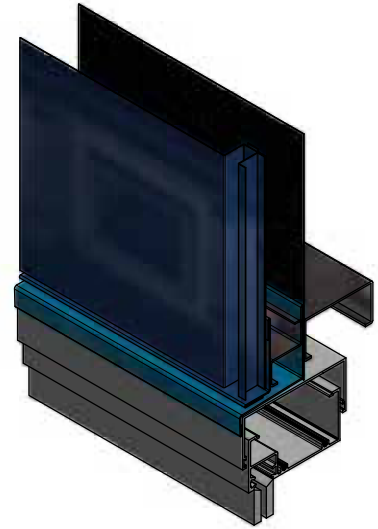
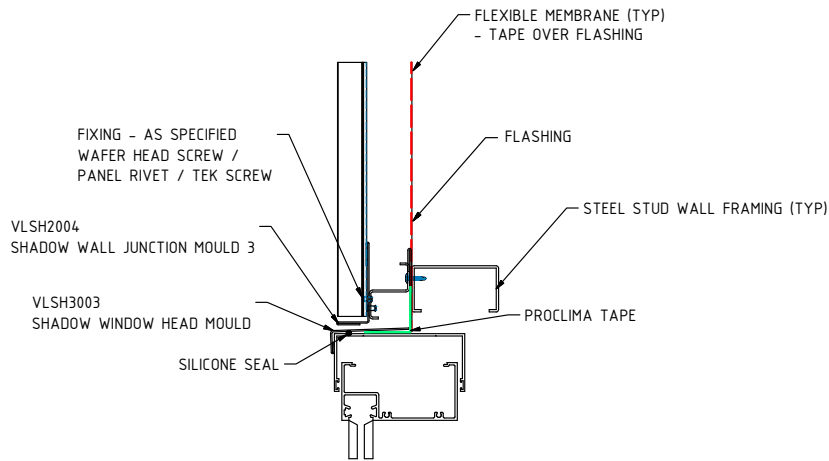

WINDOW SILL A

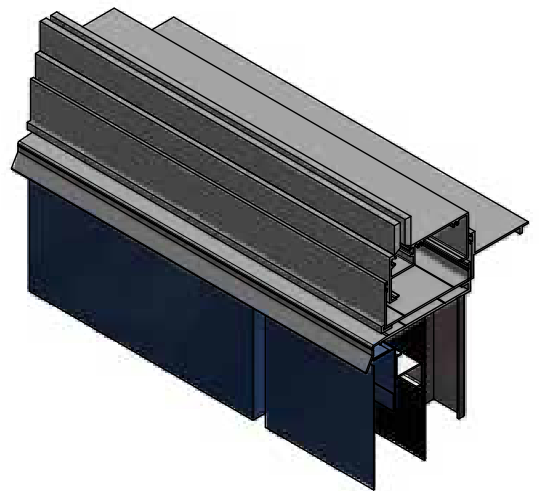
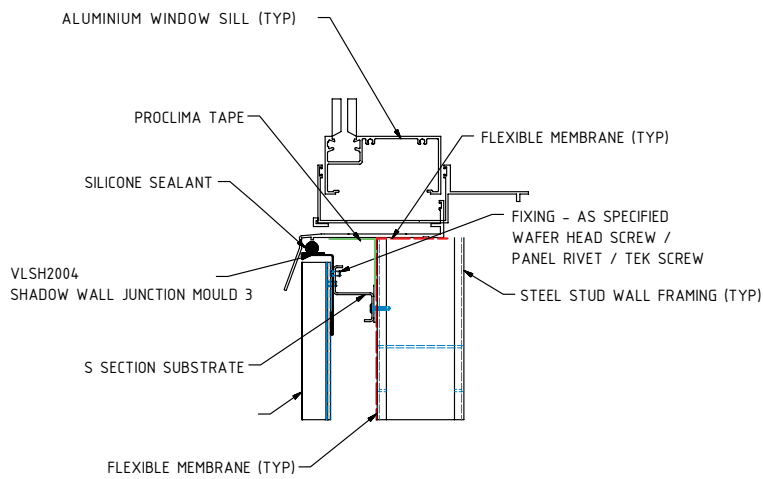

DISCLAIMER: THESE DETAILS ARE LIMITED TO THE GENERALISED DESIGN SPECIFICATION FOR FAIRVIEW VITRALOC, AND ARE INTENDED FOR USE BY A TECHNICALLY SKILLED PERSON ONLY. ANY USE OF THE SAME IS AT THEIR OWN DISCRETION AND RISK. © FVA GROUP PTY. LTD.

WINDOW SILL B

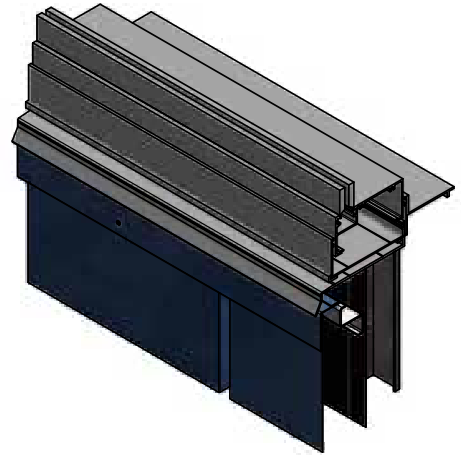
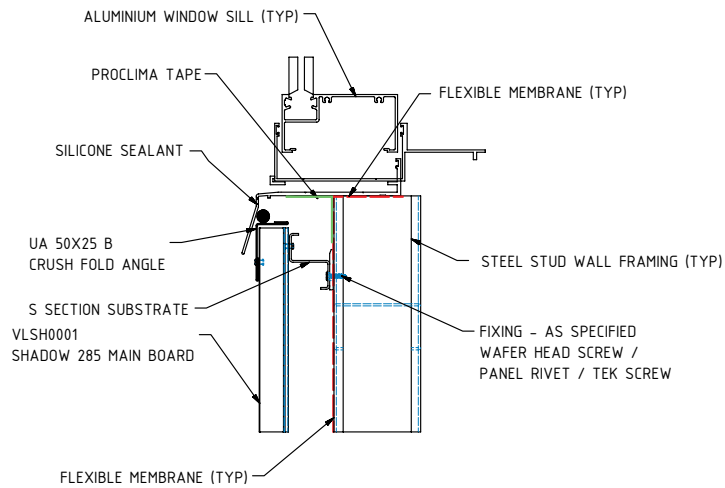

PANEL END DETAIL FLOOR A

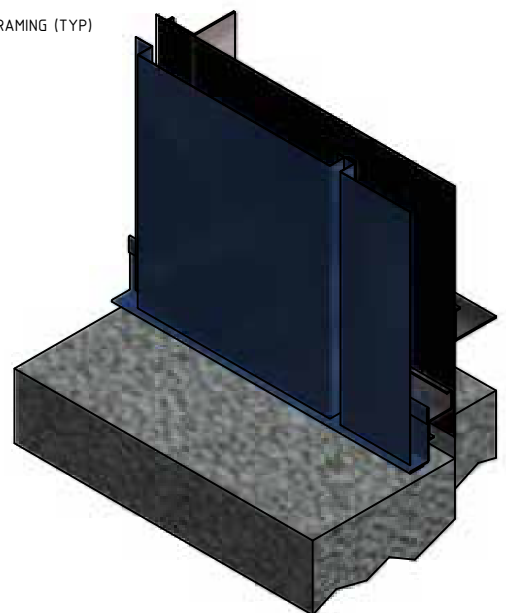
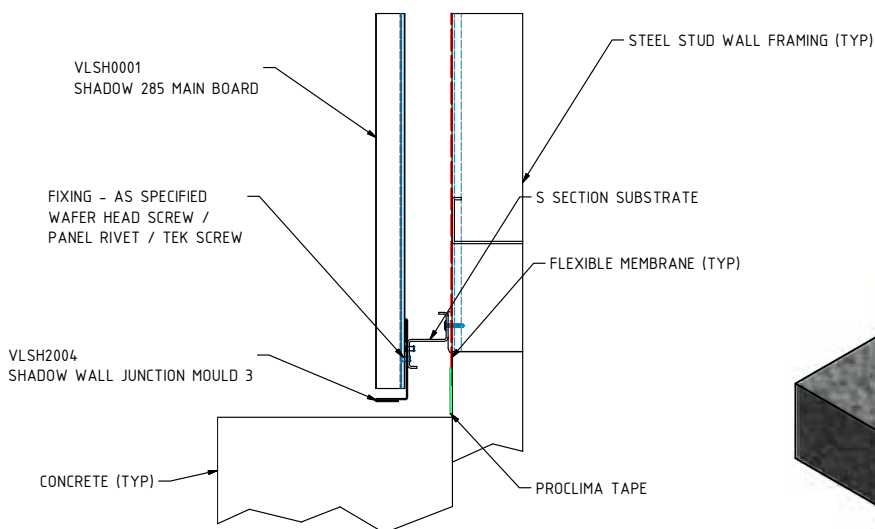

DISCLAIMER: THESE DETAILS ARE LIMITED TO THE GENERALISED DESIGN SPECIFICATION FOR FAIRVIEW VITRALOC, AND ARE INTENDED FOR USE BY A TECHNICALLY SKILLED PERSON ONLY. ANY USE OF THE SAME IS AT THEIR OWN DISCRETION AND RISK. © FVA GROUP PTY. LTD.

PANEL END DETAIL FLOOR B

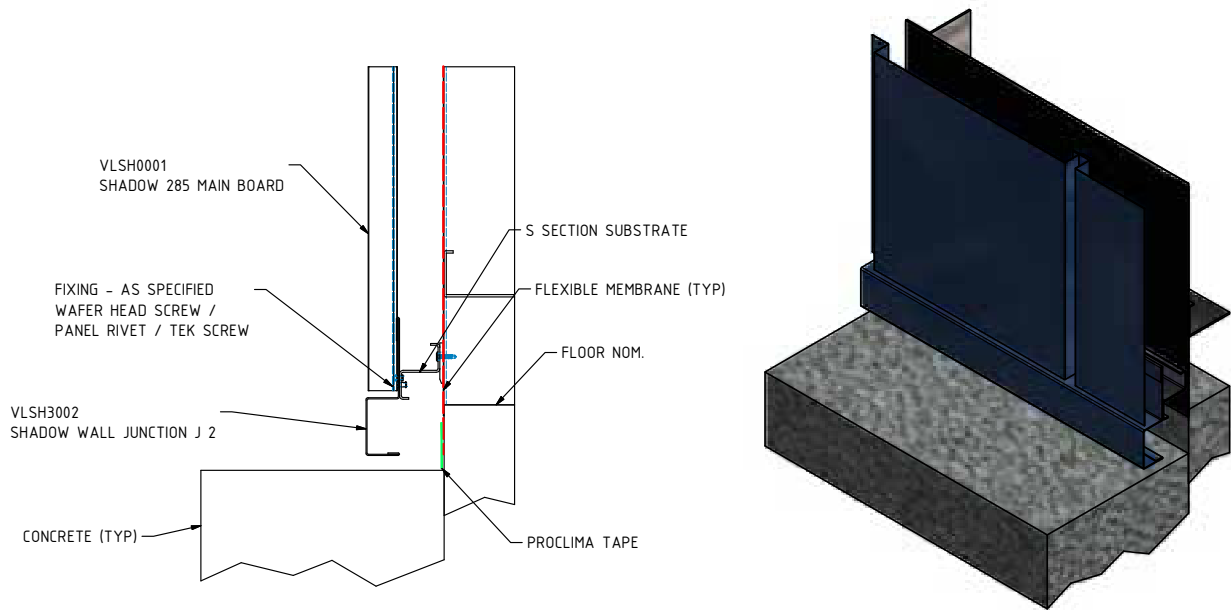

SOFFIT JUNCTION A

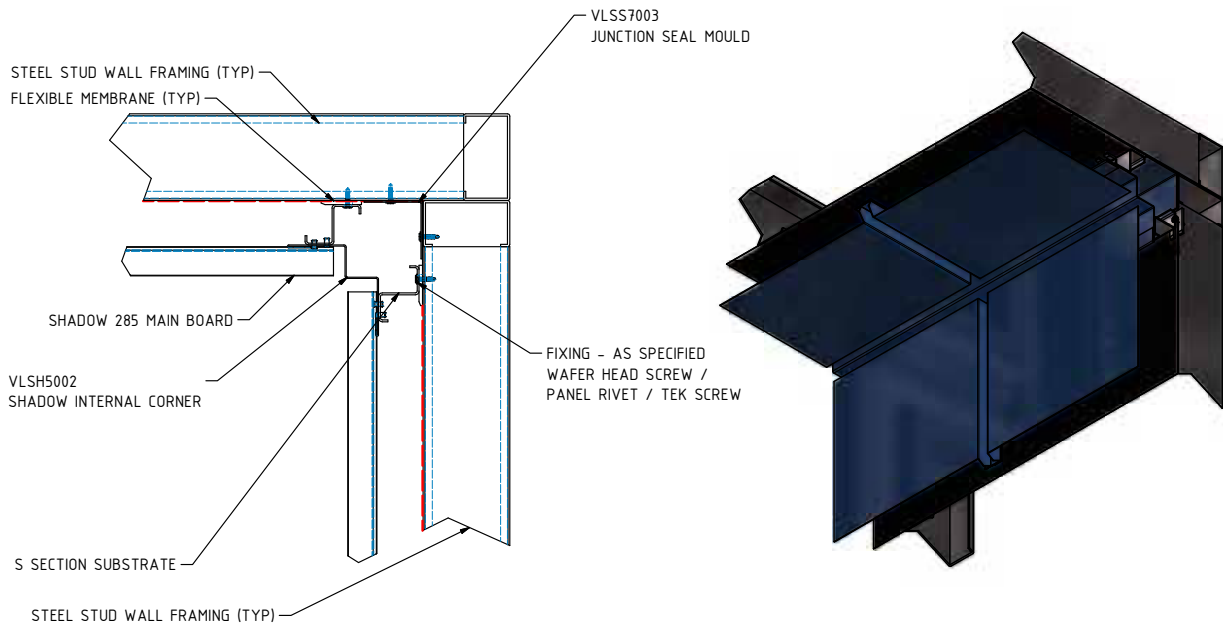

DISCLAIMER: THESE DETAILS ARE LIMITED TO THE GENERALISED DESIGN SPECIFICATION FOR FAIRVIEW VITRALOC, AND ARE INTENDED FOR USE BY A TECHNICALLY SKILLED PERSON ONLY. ANY USE OF THE SAME IS AT THEIR OWN DISCRETION AND RISK. © FVA GROUP PTY. LTD.

SOFFIT JUNCTION B1

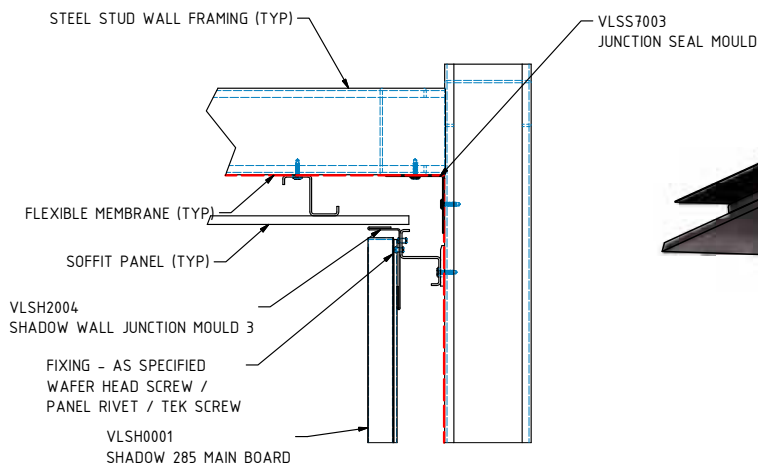

SOFFIT JUNCTION B2

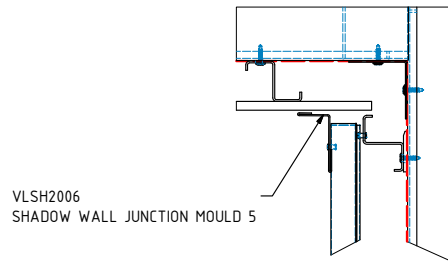

SOFFIT JUNCTION C

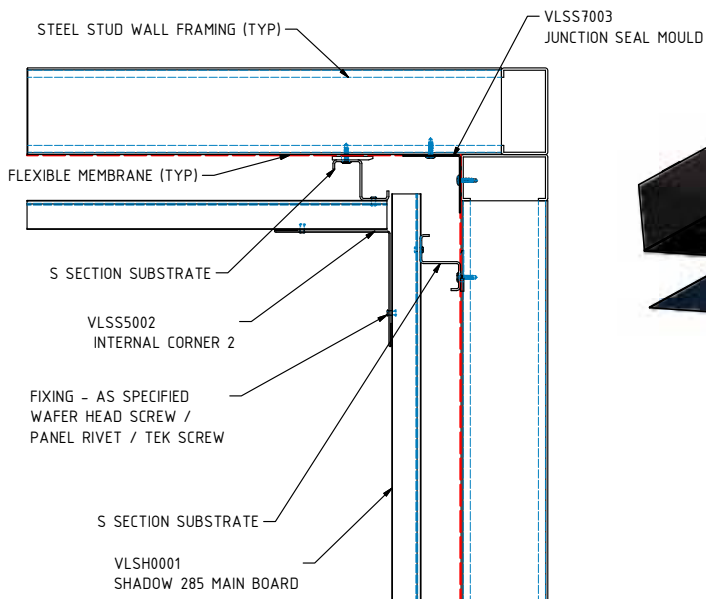

DISCLAIMER: THESE DETAILS ARE LIMITED TO THE GENERALISED DESIGN SPECIFICATION FOR FAIRVIEW VITRALOC, AND ARE INTENDED FOR USE BY A TECHNICALLY SKILLED PERSON ONLY. ANY USE OF THE SAME IS AT THEIR OWN DISCRETION AND RISK. © FVA GROUP PTY. LTD.

PARAPET AND GUTTER DETAIL A

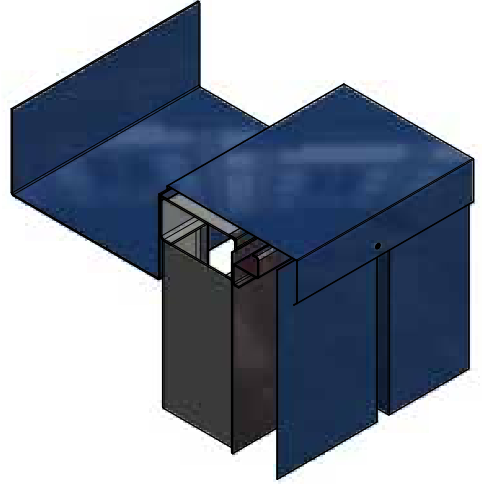
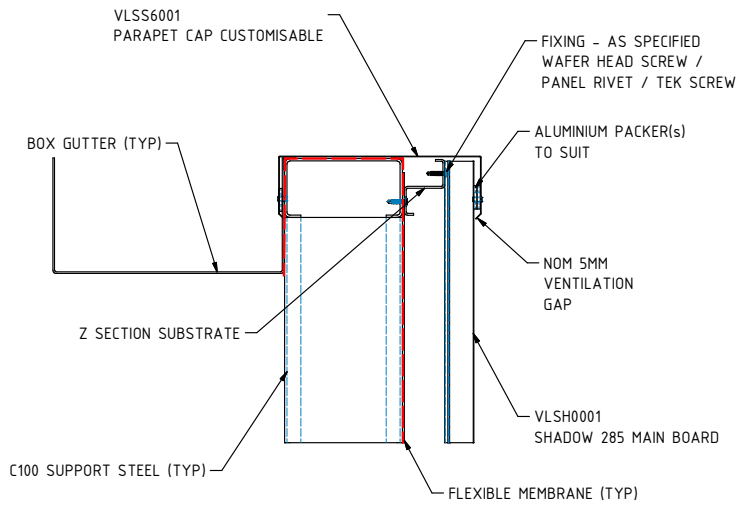

PARAPET AND GUTTER DETAIL B

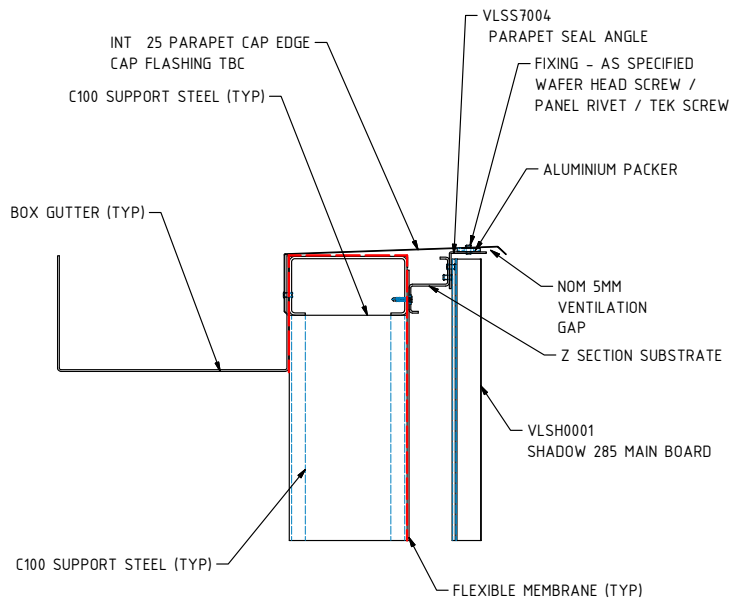

DISCLAIMER: THESE DETAILS ARE LIMITED TO THE GENERALISED DESIGN SPECIFICATION FOR FAIRVIEW VITRALOC, AND ARE INTENDED FOR USE BY A TECHNICALLY SKILLED PERSON ONLY. ANY USE OF THE SAME IS AT THEIR OWN DISCRETION AND RISK. © FVA GROUP PTY. LTD.

SLAB JUNCTION A

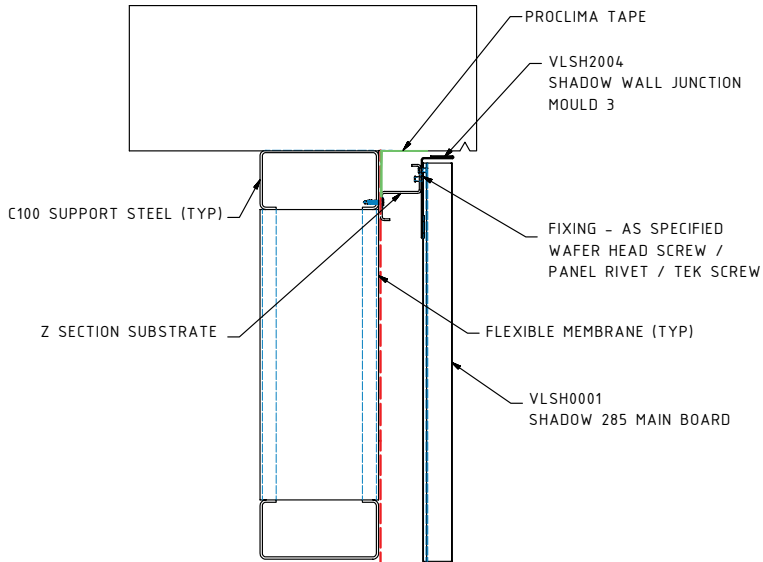

SLAB JUNCTION B

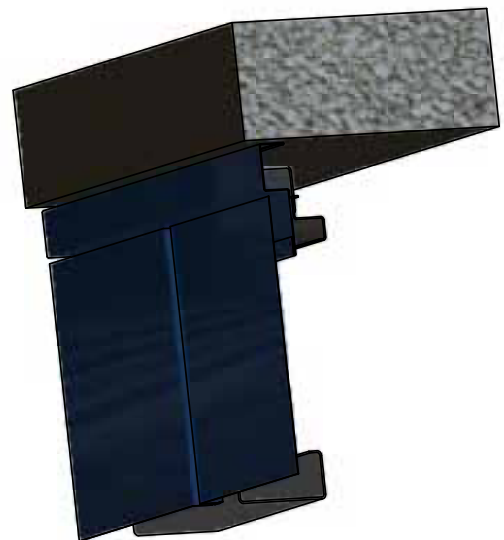
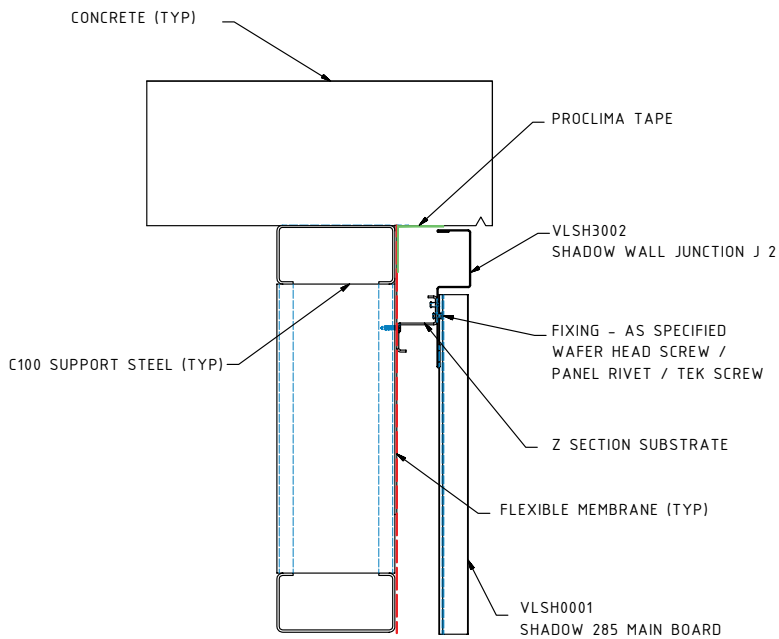

DISCLAIMER: THESE DETAILS ARE LIMITED TO THE GENERALISED DESIGN SPECIFICATION FOR FAIRVIEW VITRALOC, AND ARE INTENDED FOR USE BY A TECHNICALLY SKILLED PERSON ONLY. ANY USE OF THE SAME IS AT THEIR OWN DISCRETION AND RISK. © FVA GROUP PTY. LTD.

SLAB JUNCTION C

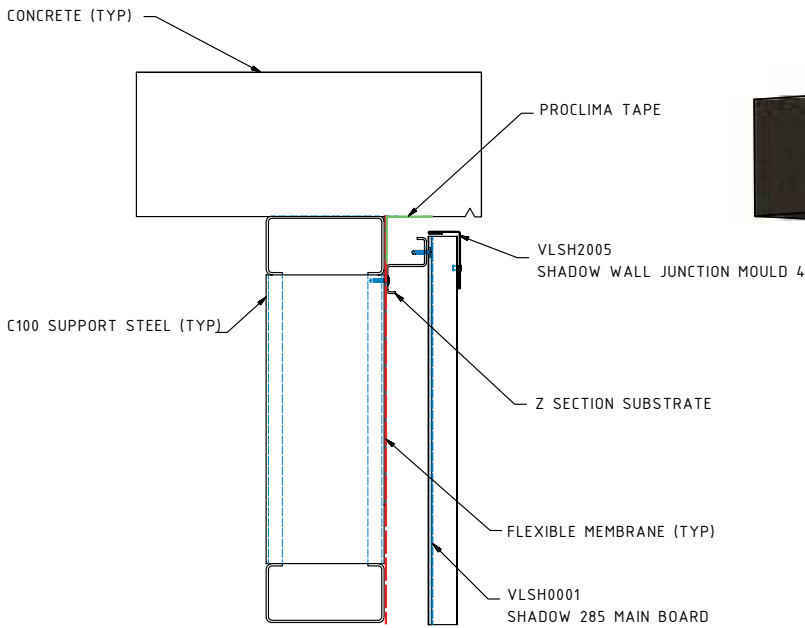

SHADOW HORIZONTAL PANEL CONNECTION DETAIL

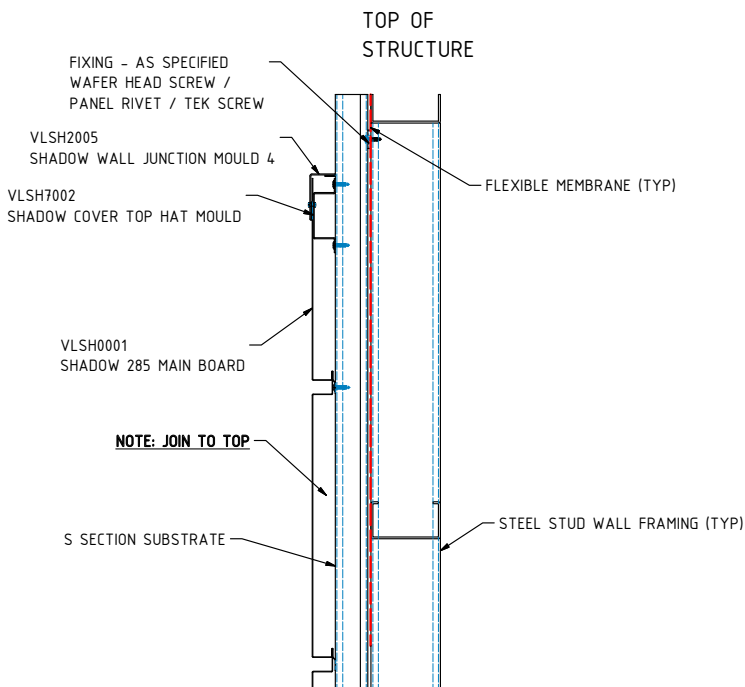

DISCLAIMER: THESE DETAILS ARE LIMITED TO THE GENERALISED DESIGN SPECIFICATION FOR FAIRVIEW VITRALOC, AND ARE INTENDED FOR USE BY A TECHNICALLY SKILLED PERSON ONLY. ANY USE OF THE SAME IS AT THEIR OWN DISCRETION AND RISK. © FVA GROUP PTY. LTD.

WALL FLOOR JUNCTION - A

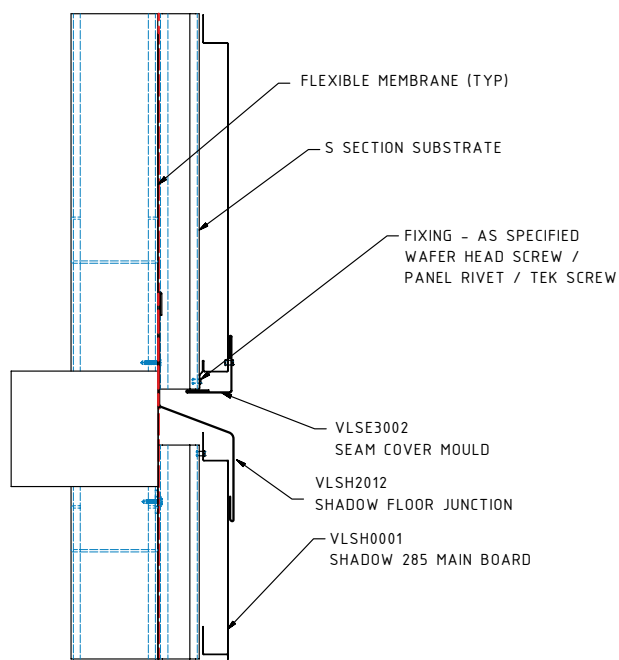

WALL FLOOR JUNCTION - B

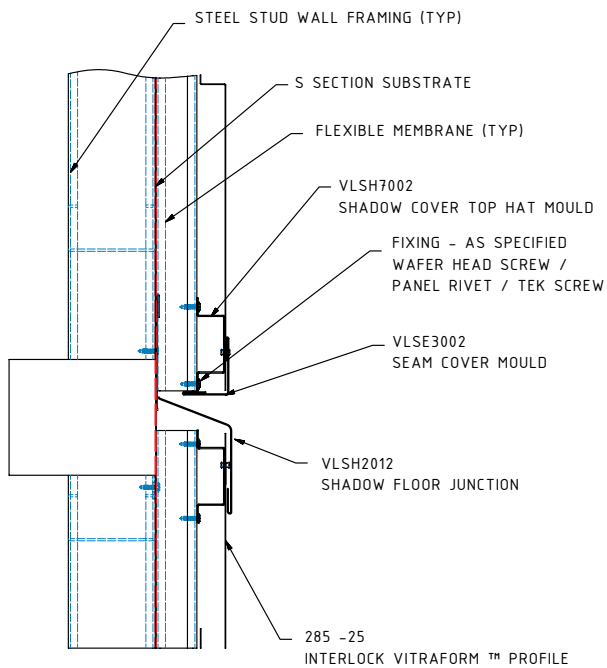

DISCLAIMER: THESE DETAILS ARE LIMITED TO THE GENERALISED DESIGN SPECIFICATION FOR FAIRVIEW VITRALOC, AND ARE INTENDED FOR USE BY A TECHNICALLY SKILLED PERSON ONLY. ANY USE OF THE SAME IS AT THEIR OWN DISCRETION AND RISK. © FVA GROUP PTY. LTD.

WALL JUNCTION A1

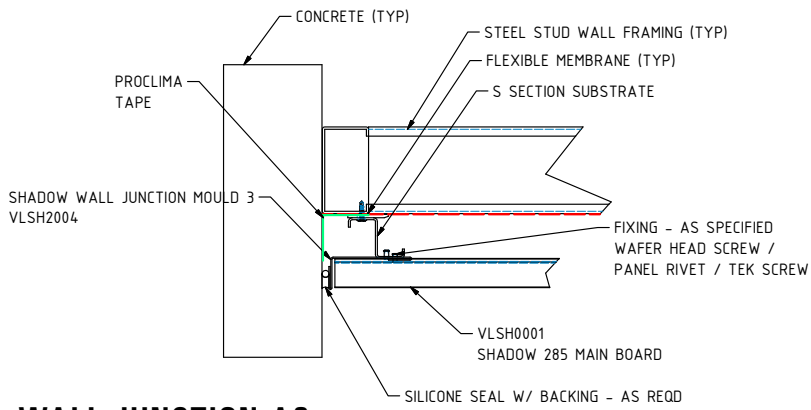

WALL JUNCTION A2

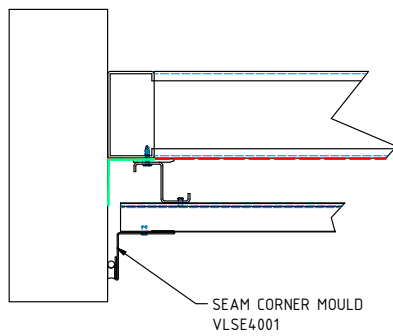

WALL JUNCTION B

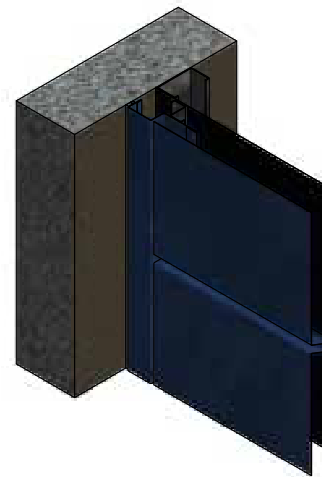
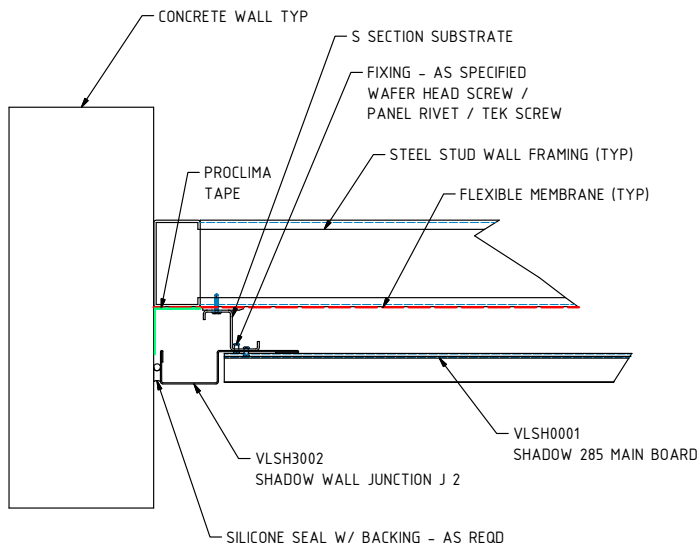

DISCLAIMER: THESE DETAILS ARE LIMITED TO THE GENERALISED DESIGN SPECIFICATION FOR FAIRVIEW VITRALOC, AND ARE INTENDED FOR USE BY A TECHNICALLY SKILLED PERSON ONLY. ANY USE OF THE SAME IS AT THEIR OWN DISCRETION AND RISK. © FVA GROUP PTY. LTD.

WALL JUNCTION C

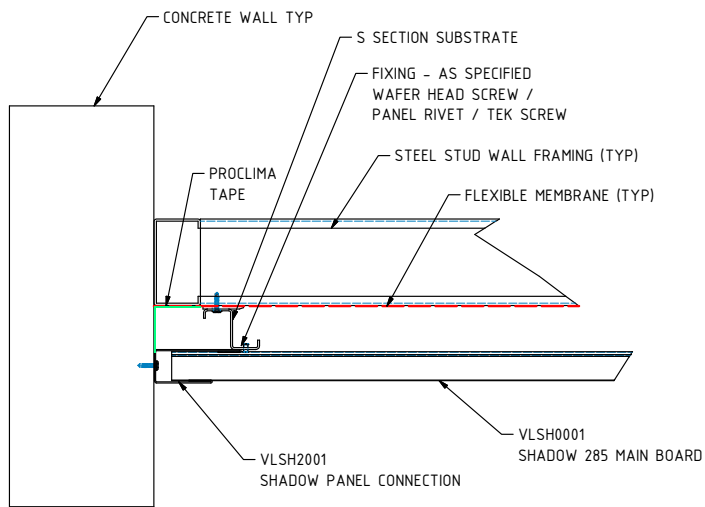

INTERNAL CORNER DETAIL

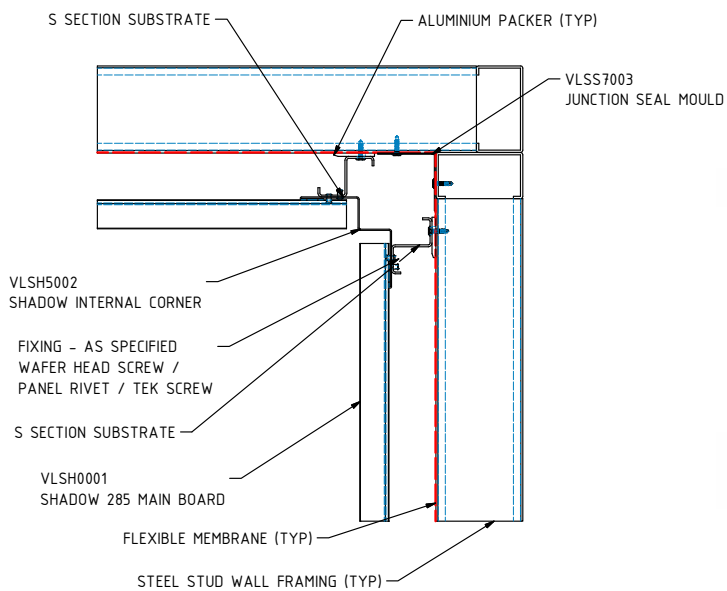

DISCLAIMER: THESE DETAILS ARE LIMITED TO THE GENERALISED DESIGN SPECIFICATION FOR FAIRVIEW VITRALOC, AND ARE INTENDED FOR USE BY A TECHNICALLY SKILLED PERSON ONLY. ANY USE OF THE SAME IS AT THEIR OWN DISCRETION AND RISK. © FVA GROUP PTY. LTD.

INTERNAL CORNER B

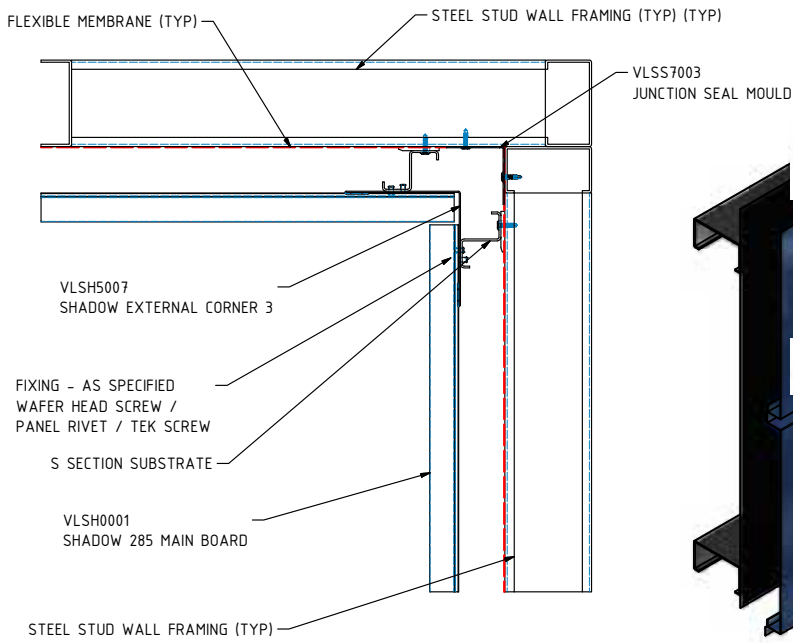

EXTERNAL CORNER DETAIL A

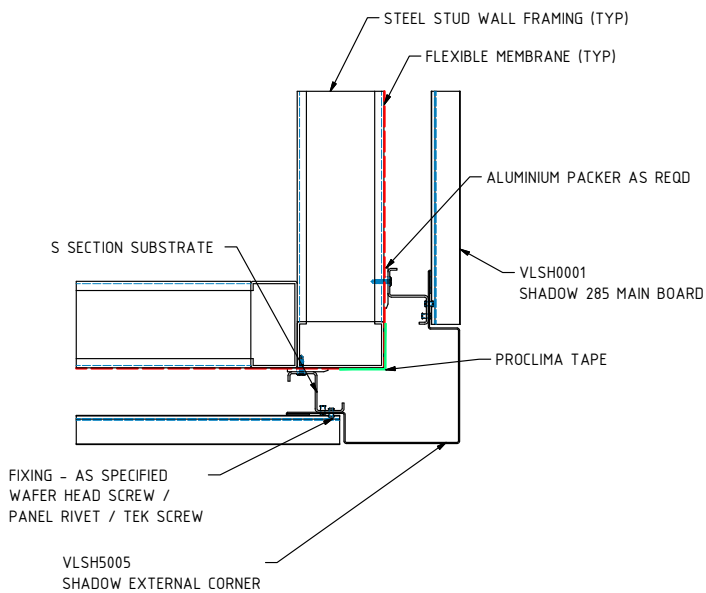

DISCLAIMER: THESE DETAILS ARE LIMITED TO THE GENERALISED DESIGN SPECIFICATION FOR FAIRVIEW VITRALOC, AND ARE INTENDED FOR USE BY A TECHNICALLY SKILLED PERSON ONLY. ANY USE OF THE SAME IS AT THEIR OWN DISCRETION AND RISK. © FVA GROUP PTY. LTD.

EXTERNAL CORNER DETAIL B

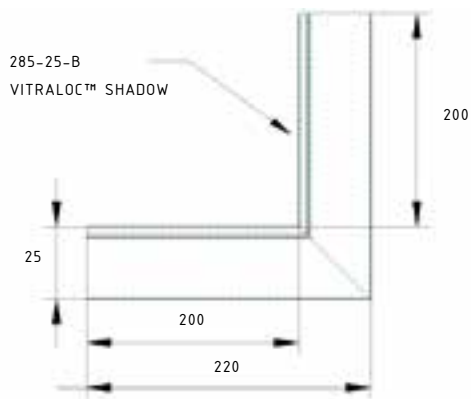

WINDOW HEAD

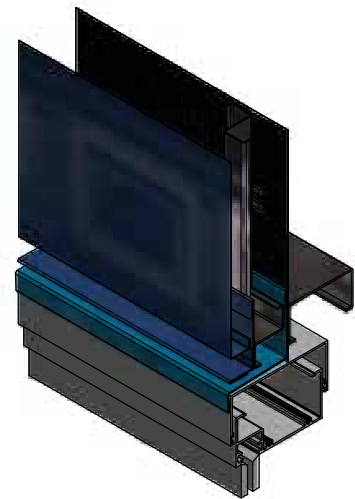
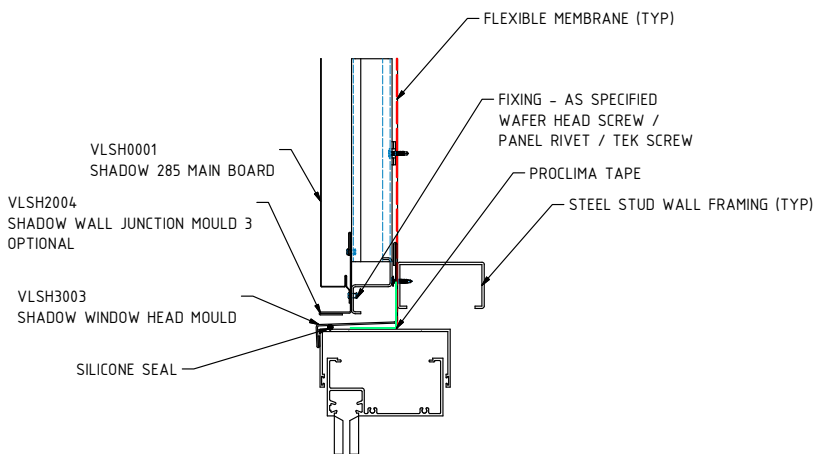

DISCLAIMER: THESE DETAILS ARE LIMITED TO THE GENERALISED DESIGN SPECIFICATION FOR FAIRVIEW VITRALOC, AND ARE INTENDED FOR USE BY A TECHNICALLY SKILLED PERSON ONLY. ANY USE OF THE SAME IS AT THEIR OWN DISCRETION AND RISK. © FVA GROUP PTY. LTD.

WINDOW SILL

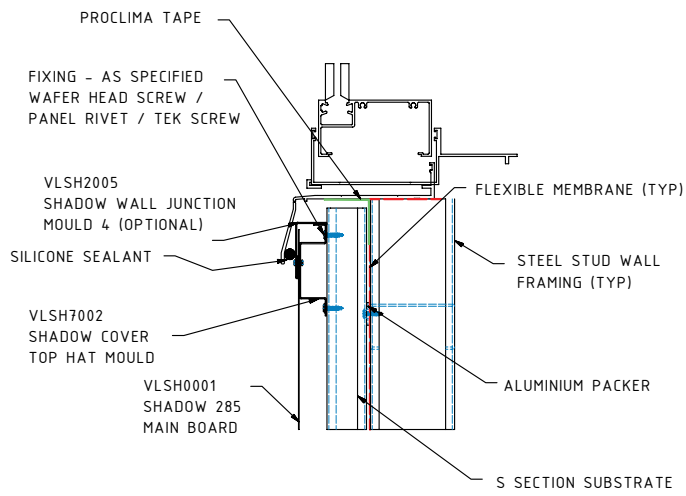

PANEL END DETAIL FLOOR A

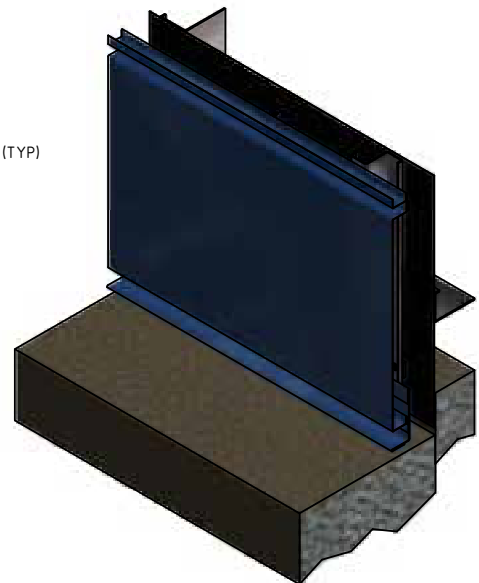
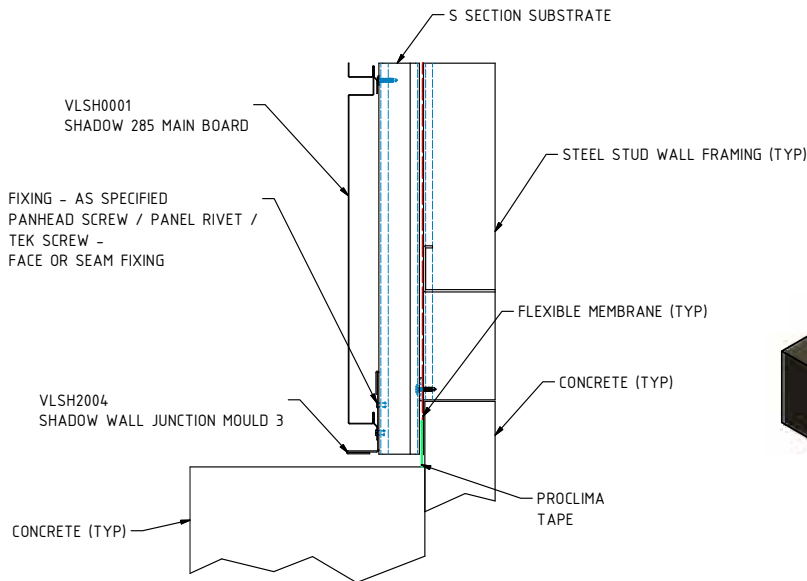

DISCLAIMER: THESE DETAILS ARE LIMITED TO THE GENERALISED DESIGN SPECIFICATION FOR FAIRVIEW VITRALOC, AND ARE INTENDED FOR USE BY A TECHNICALLY SKILLED PERSON ONLY. ANY USE OF THE SAME IS AT THEIR OWN DISCRETION AND RISK. © FVA GROUP PTY. LTD.

PANEL END DETAIL FLOOR B

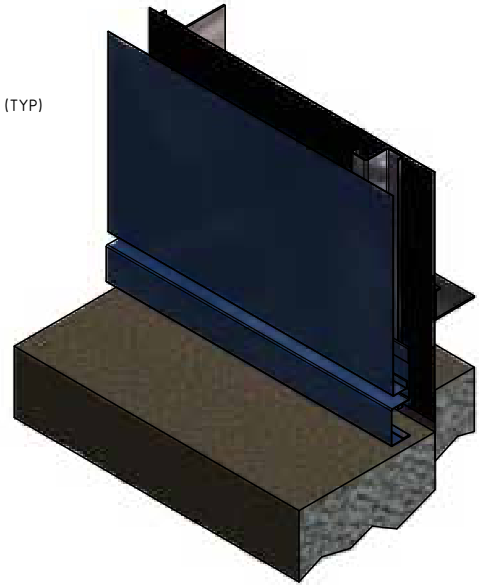
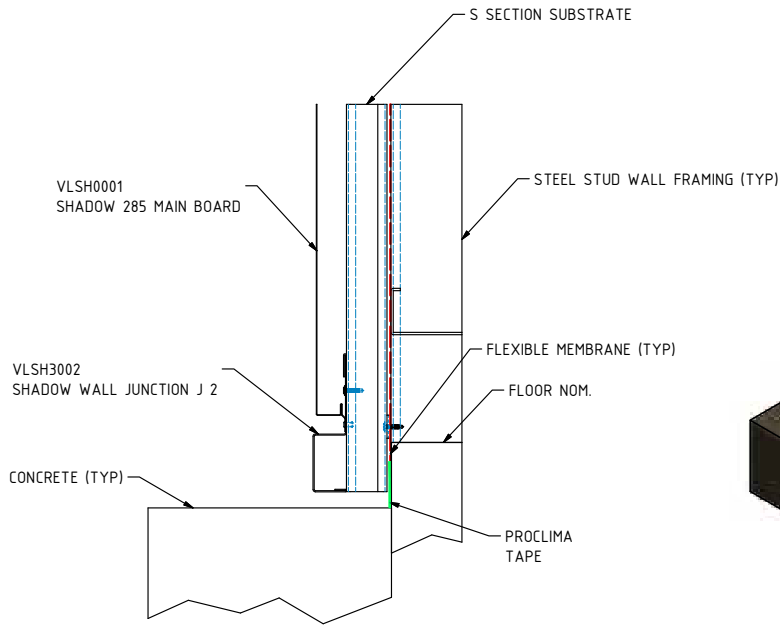

SOFFIT JUNCTION A

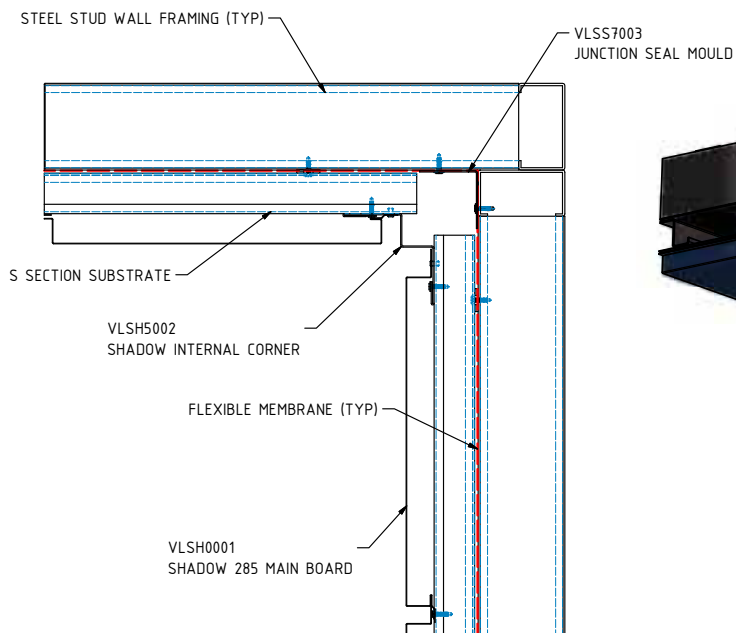

DISCLAIMER: THESE DETAILS ARE LIMITED TO THE GENERALISED DESIGN SPECIFICATION FOR FAIRVIEW VITRALOC, AND ARE INTENDED FOR USE BY A TECHNICALLY SKILLED PERSON ONLY. ANY USE OF THE SAME IS AT THEIR OWN DISCRETION AND RISK. © FVA GROUP PTY. LTD.

SOFFIT JUNCTION B

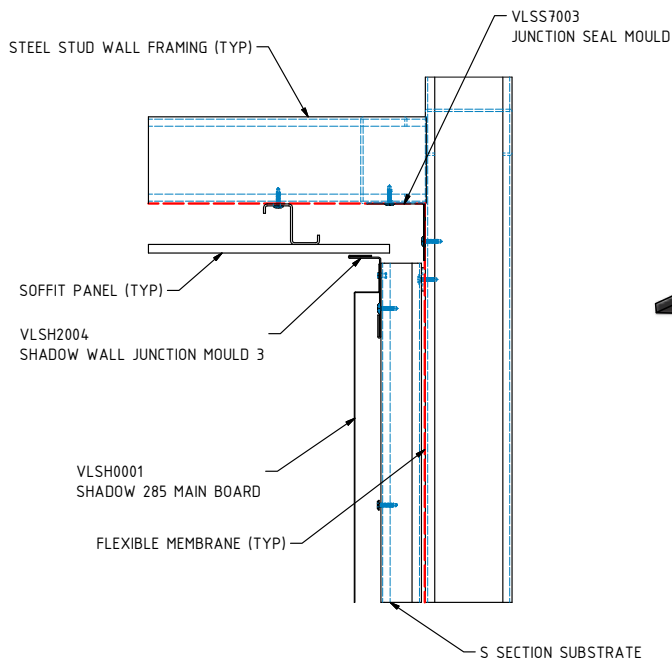

SOFFIT JUNCTION C

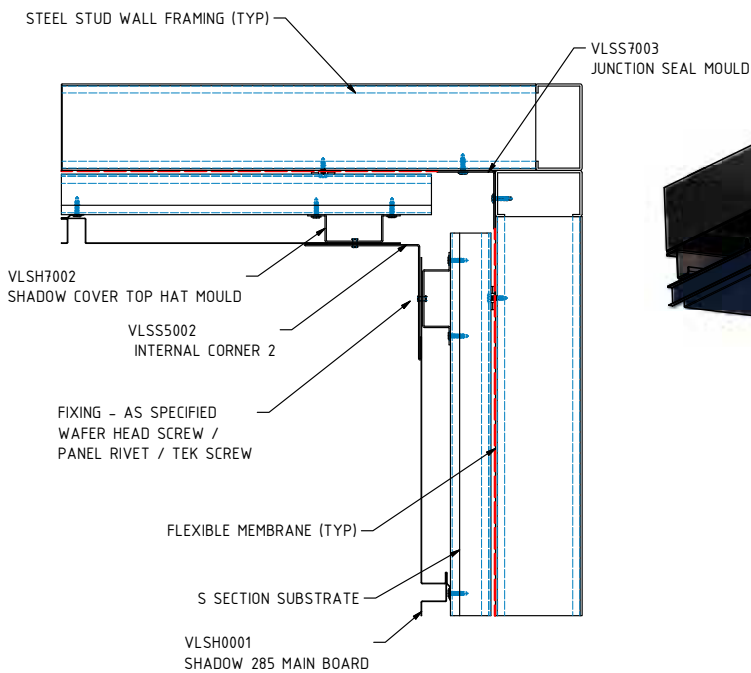

DISCLAIMER: THESE DETAILS ARE LIMITED TO THE GENERALISED DESIGN SPECIFICATION FOR FAIRVIEW VITRALOC, AND ARE INTENDED FOR USE BY A TECHNICALLY SKILLED PERSON ONLY. ANY USE OF THE SAME IS AT THEIR OWN DISCRETION AND RISK. © FVA GROUP PTY. LTD.

SOFFIT JUNCTION D

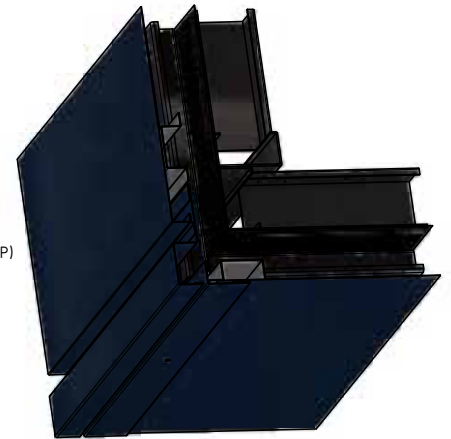
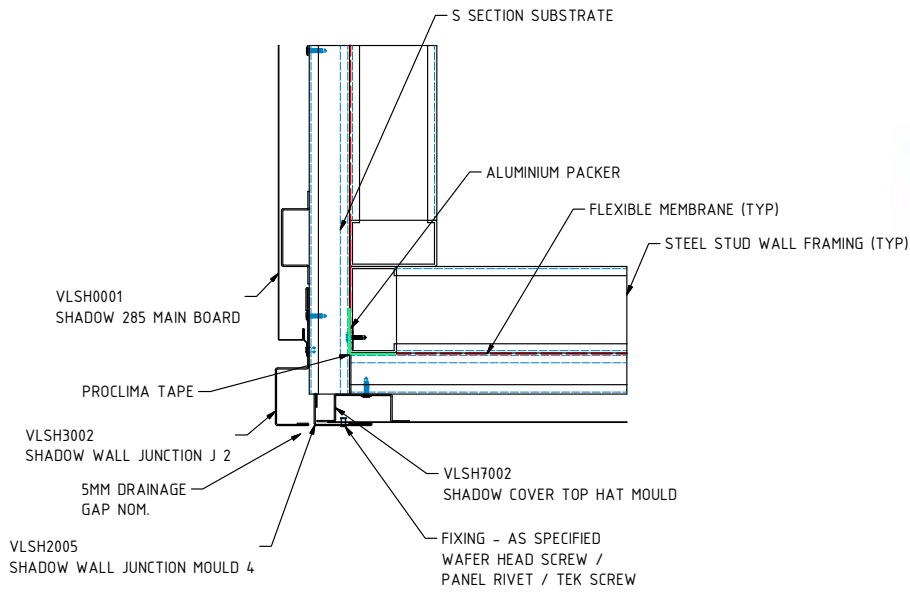

SOFFIT JUNCTION E

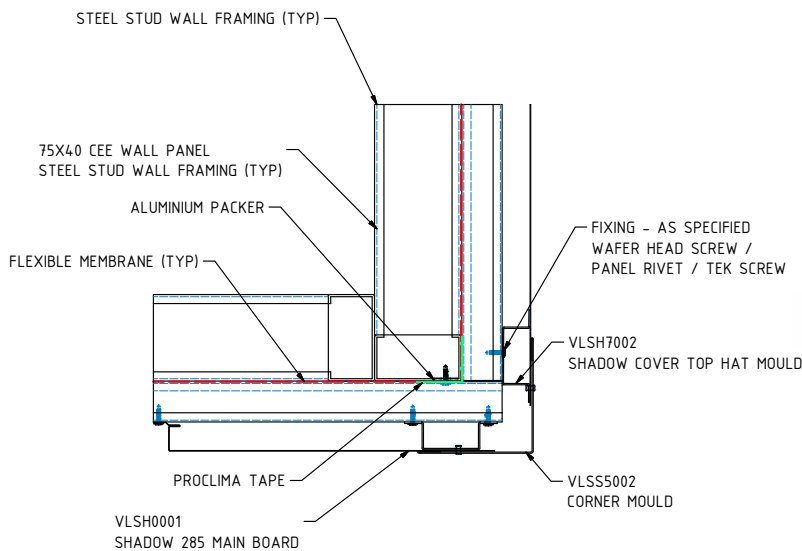

DISCLAIMER: THESE DETAILS ARE LIMITED TO THE GENERALISED DESIGN SPECIFICATION FOR FAIRVIEW VITRALOC, AND ARE INTENDED FOR USE BY A TECHNICALLY SKILLED PERSON ONLY. ANY USE OF THE SAME IS AT THEIR OWN DISCRETION AND RISK. © FVA GROUP PTY. LTD.

PARAPET AND GUTTER DETAIL A

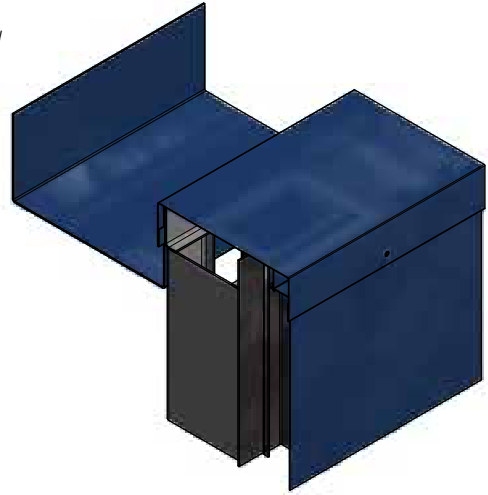
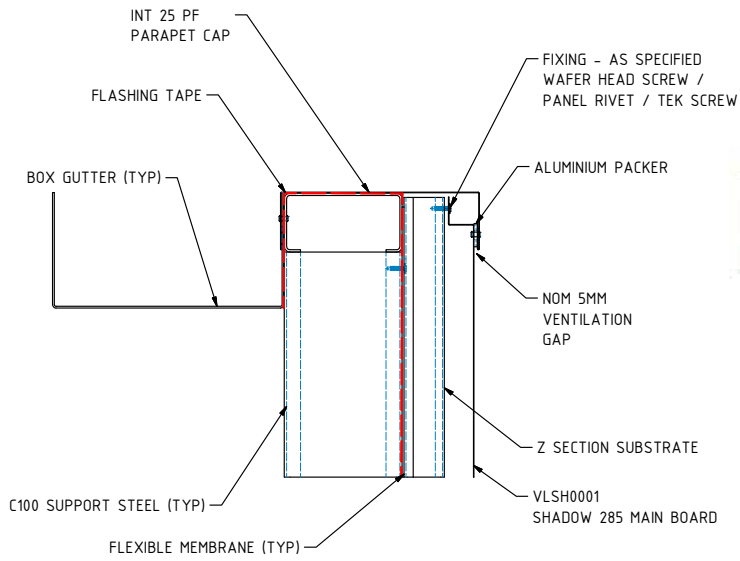

PARAPET AND GUTTER DETAIL B

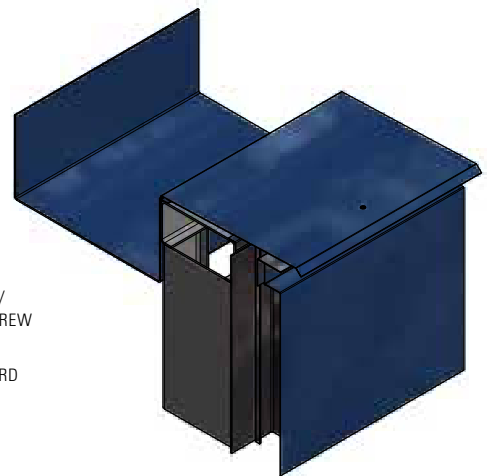
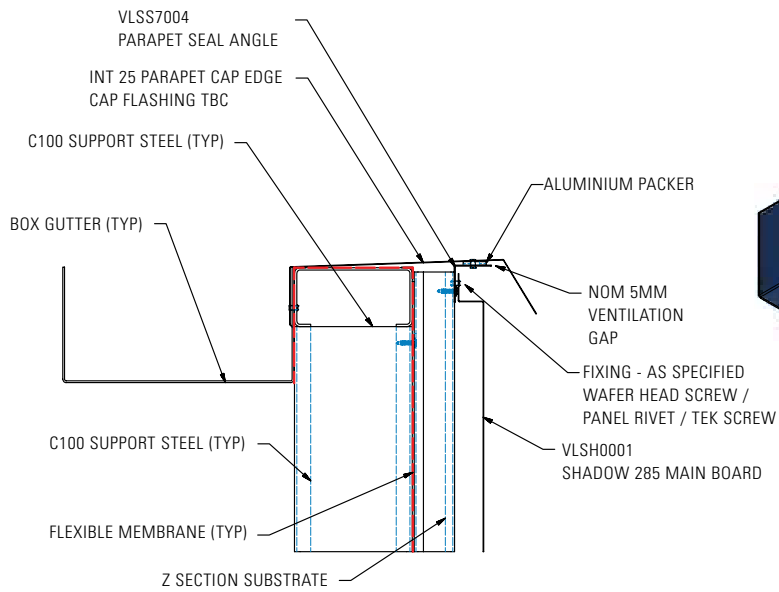

DISCLAIMER: THESE DETAILS ARE LIMITED TO THE GENERALISED DESIGN SPECIFICATION FOR FAIRVIEW VITRALOC, AND ARE INTENDED FOR USE BY A TECHNICALLY SKILLED PERSON ONLY. ANY USE OF THE SAME IS AT THEIR OWN DISCRETION AND RISK. © FVA GROUP PTY. LTD.

PARAPET AND GUTTER DETAIL C

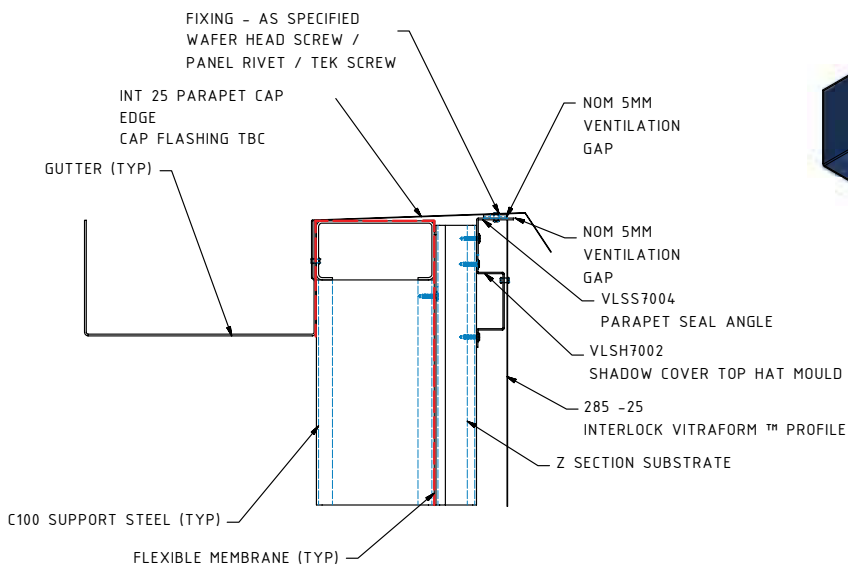

SLAB JUNCTION A

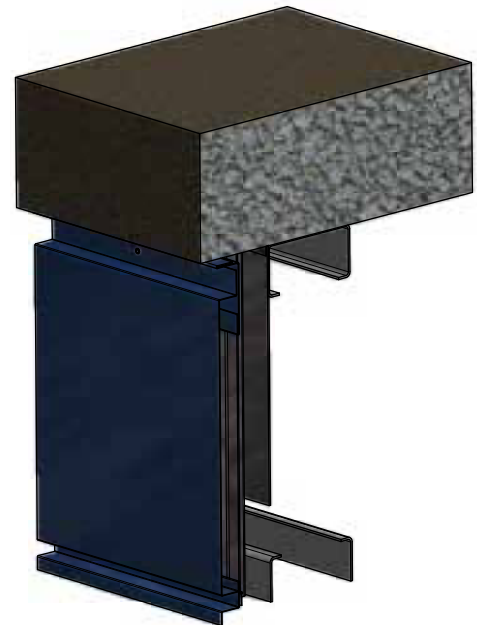
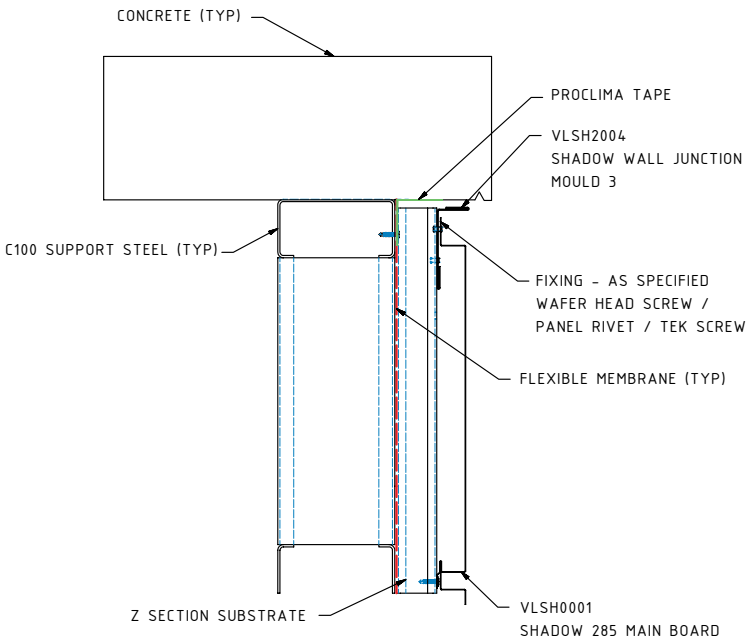

DISCLAIMER: THESE DETAILS ARE LIMITED TO THE GENERALISED DESIGN SPECIFICATION FOR FAIRVIEW VITRALOC, AND ARE INTENDED FOR USE BY A TECHNICALLY SKILLED PERSON ONLY. ANY USE OF THE SAME IS AT THEIR OWN DISCRETION AND RISK. © FVA GROUP PTY. LTD.

SLAB JUNCTION B

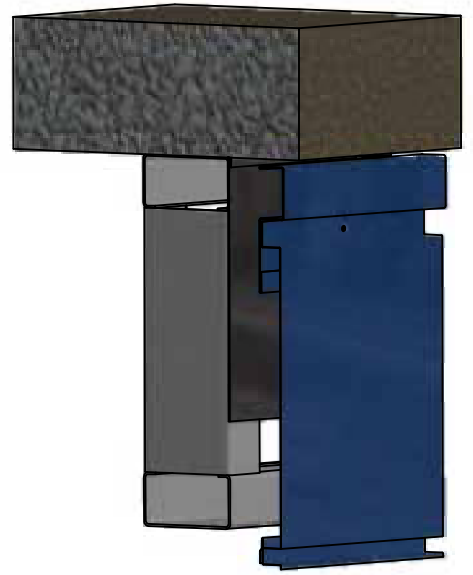
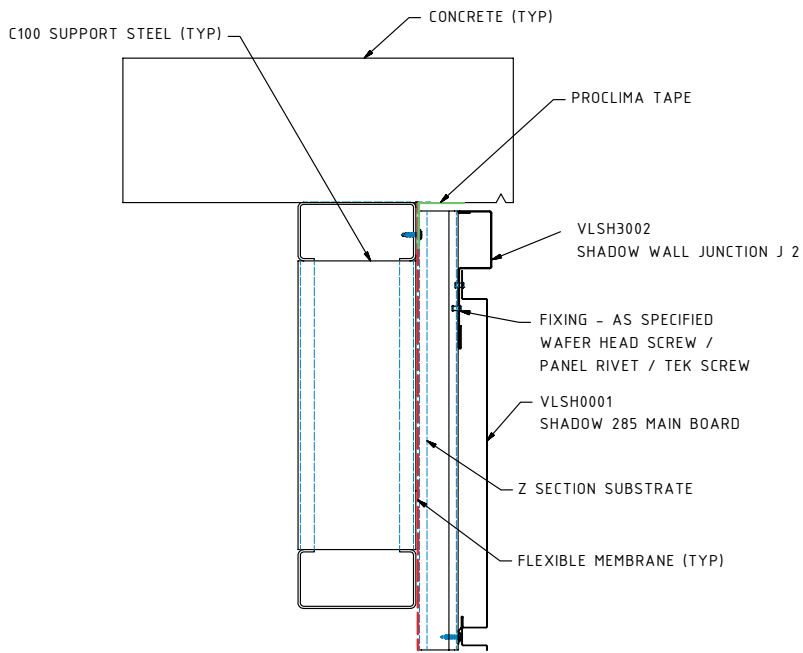

SLAB JUNCTION C

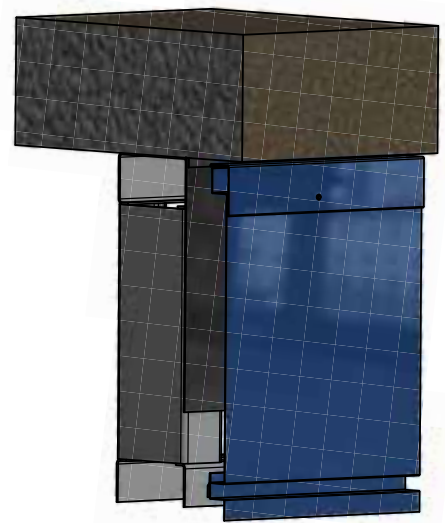
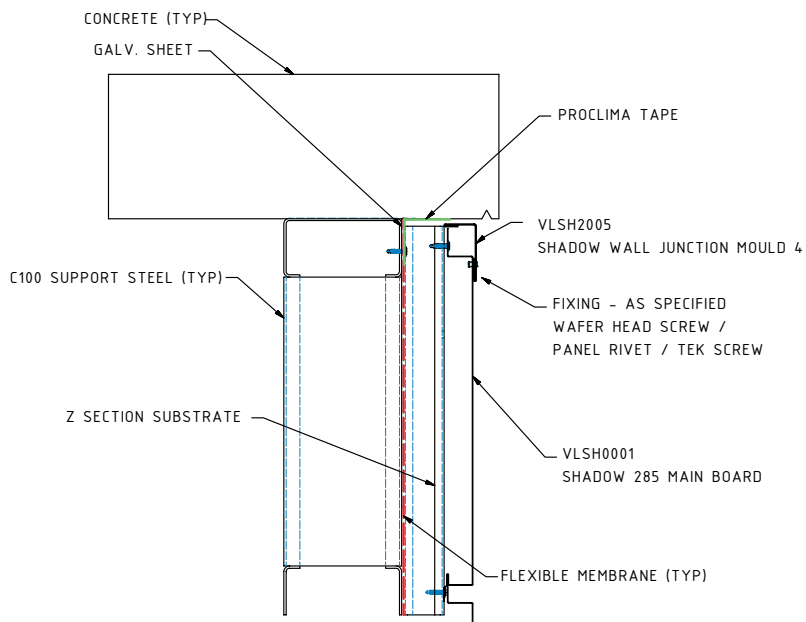

DISCLAIMER: THESE DETAILS ARE LIMITED TO THE GENERALISED DESIGN SPECIFICATION FOR FAIRVIEW VITRALOC, AND ARE INTENDED FOR USE BY A TECHNICALLY SKILLED PERSON ONLY. ANY USE OF THE SAME IS AT THEIR OWN DISCRETION AND RISK. © FVA GROUP PTY. LTD.

8. SEAM VERTICAL AND HORIZONTAL



8.1 INSTALLATION GUIDE

STANDARD ENGAGEMENT PROCEDURE – VITRALOC SEAM 38

Vitraloc Seam 38 can be installed in both vertical and horizontal orientations using the same basic procedure.

Fixing battens for vertical and horizontal panels should be spaced at 600mm maximum centres. Closer batten spacing provide a more rigid assembly resulting in less deflection and distortion (oil-canning). Generally, 450mm spacing is recommended.

Fixing battens for vertical and horizontal panels should be spaced at 600mm maximum centres. Closer batten spacing provide a more rigid assembly resulting in less deflection and distortion (oil-canning). Generally, 450mm spacing is recommended.

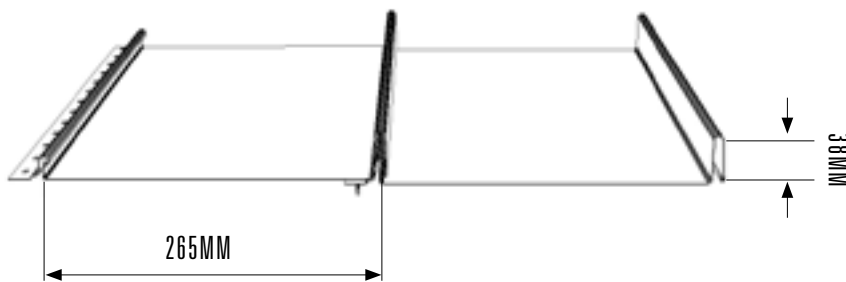

1. Starter strip.

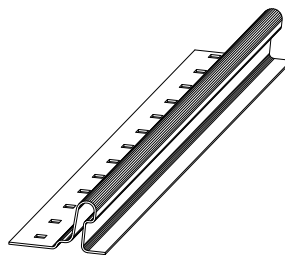

2. Secure starter strip.

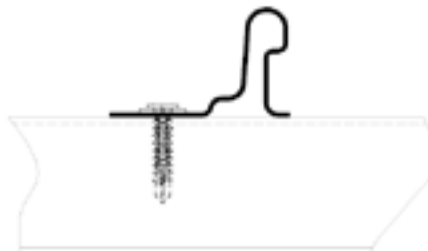

Take care to place the screws in the centre of the slotted holes to allow for expansion and contraction, however it is not always possible or practical to do so. Screws can be placed either through the slotted holes or directly through the sheet. Where screws are fitted directly through the sheet tab and where aesthetics are important, it is advisable to pre-drill an oversized hole to accommodative thermal movement of the sheet.

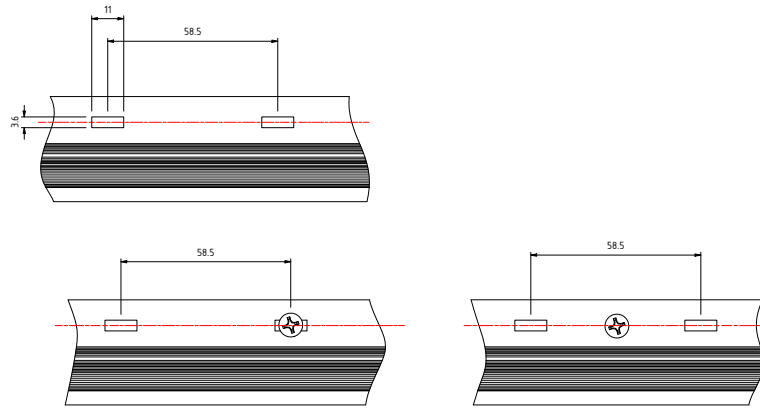

3. When installing horizontally, general consideration is given to good practice and proper drainage, hence the perforated section that runs adjacent to the underlock of the cladding sheet is installed as the top of the sheet.

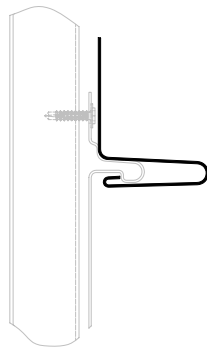

4. Align panel over and under lap ribs and apply horizontal pressure.



5. Secure into position.

Prior to screwing sheet into place, apply uniform and consistent pressure to the pan of the sheet over the location of the batten to avoid unnecessary sheet deflection or distortion that may contribute to oil-canning.



6. Repeat process for the wall run.



7. Complete flashings and detailing as per architectural specifications.



8.2 GENERAL DETAILS

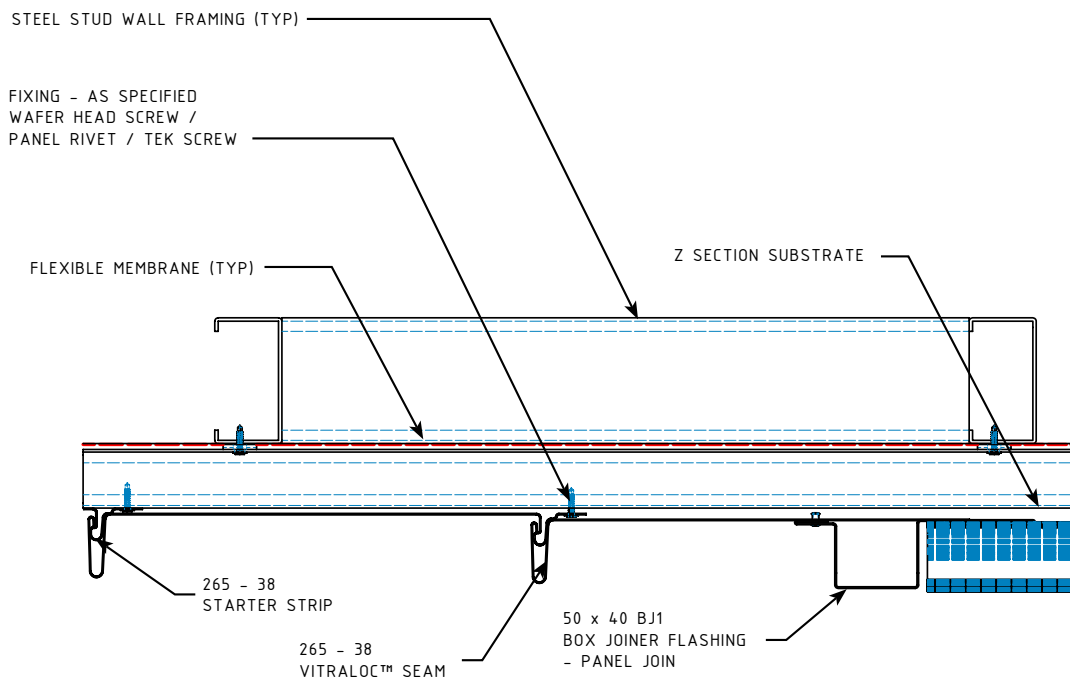

SEAM VERTICAL

PANEL CONNECTION DETAIL A

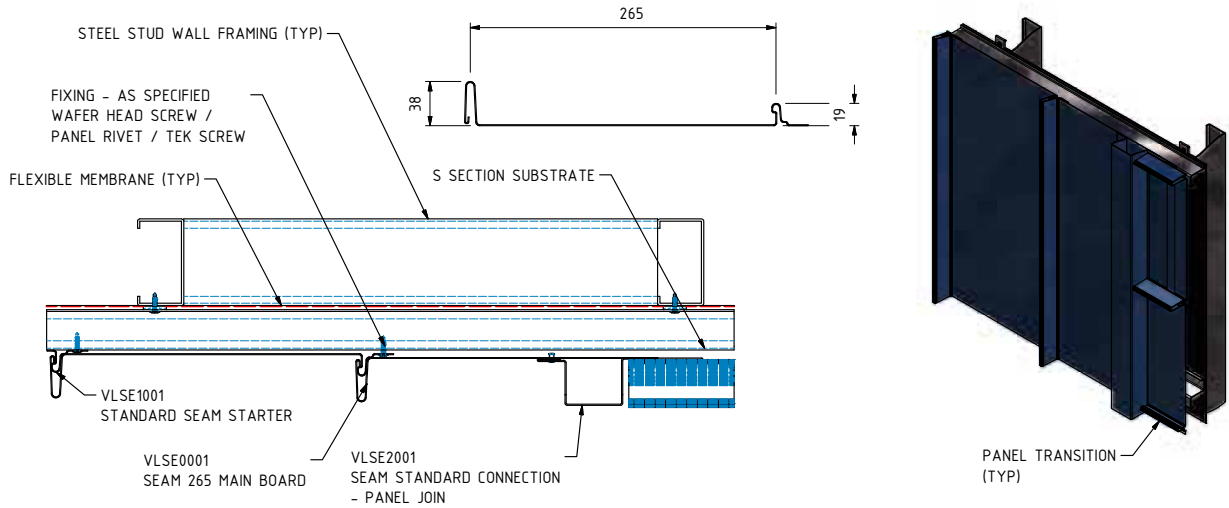

PANEL CONNECTION DETAIL B

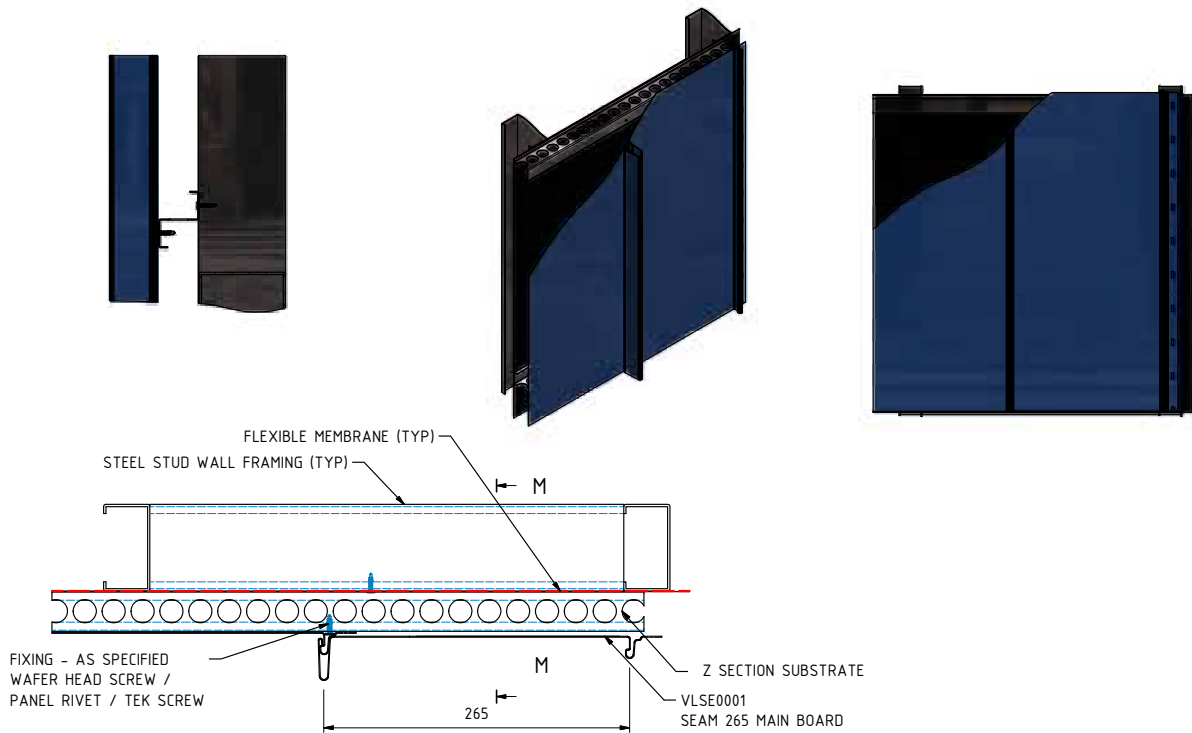

DISCLAIMER: THESE DETAILS ARE LIMITED TO THE GENERALISED DESIGN SPECIFICATION FOR FAIRVIEW VITRALOC, AND ARE INTENDED FOR USE BY A TECHNICALLY SKILLED PERSON ONLY. ANY USE OF THE SAME IS AT THEIR OWN DISCRETION AND RISK. © FVA GROUP PTY. LTD.

STARTER PANEL-A

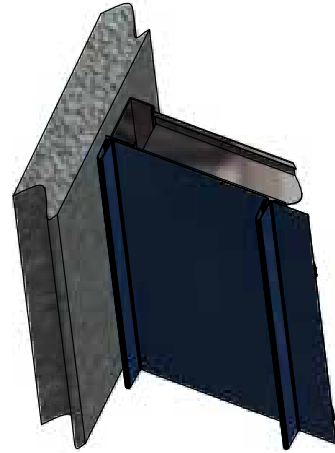
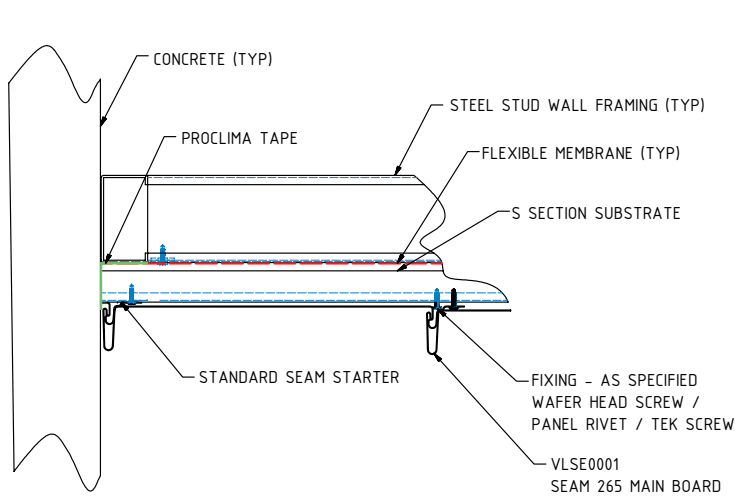

STARTER PANEL - B1

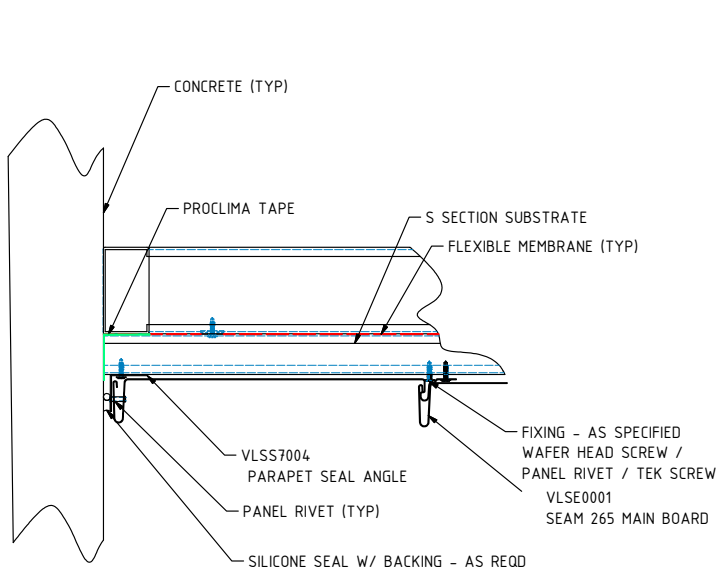

DISCLAIMER: THESE DETAILS ARE LIMITED TO THE GENERALISED DESIGN SPECIFICATION FOR FAIRVIEW VITRALOC, AND ARE INTENDED FOR USE BY A TECHNICALLY SKILLED PERSON ONLY. ANY USE OF THE SAME IS AT THEIR OWN DISCRETION AND RISK. © FVA GROUP PTY. LTD.

STARTER PANEL B2

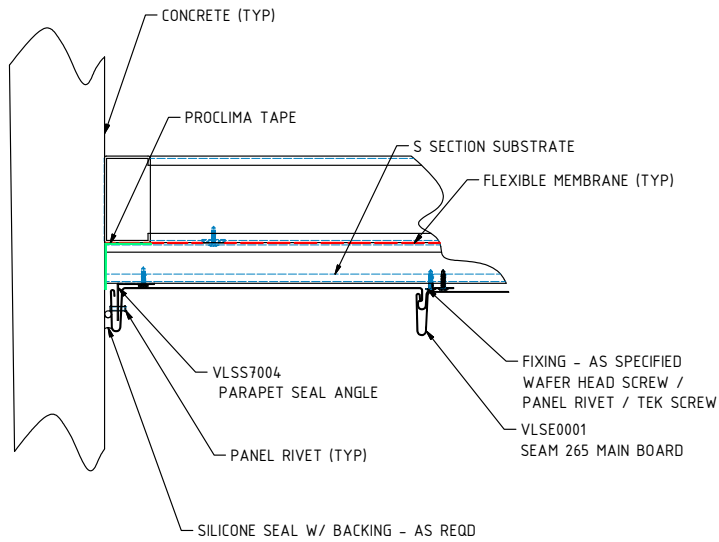

STARTER PANEL B3

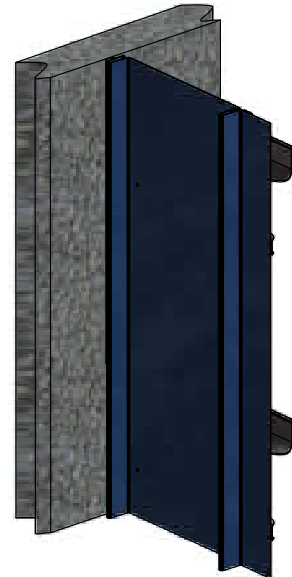
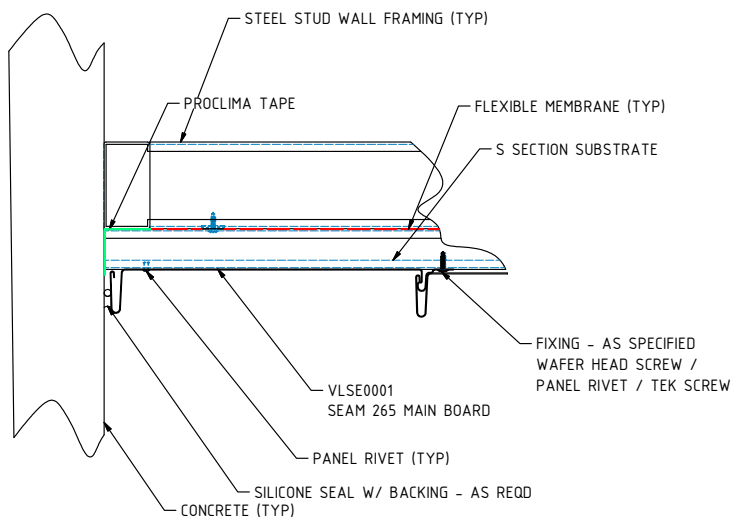

DISCLAIMER: THESE DETAILS ARE LIMITED TO THE GENERALISED DESIGN SPECIFICATION FOR FAIRVIEW VITRALOC, AND ARE INTENDED FOR USE BY A TECHNICALLY SKILLED PERSON ONLY. ANY USE OF THE SAME IS AT THEIR OWN DISCRETION AND RISK. © FVA GROUP PTY. LTD.

STARTER PANEL B4

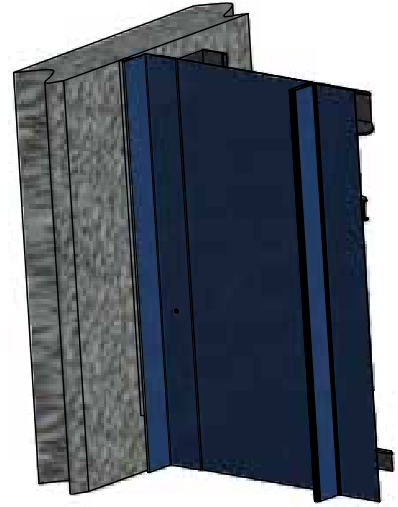
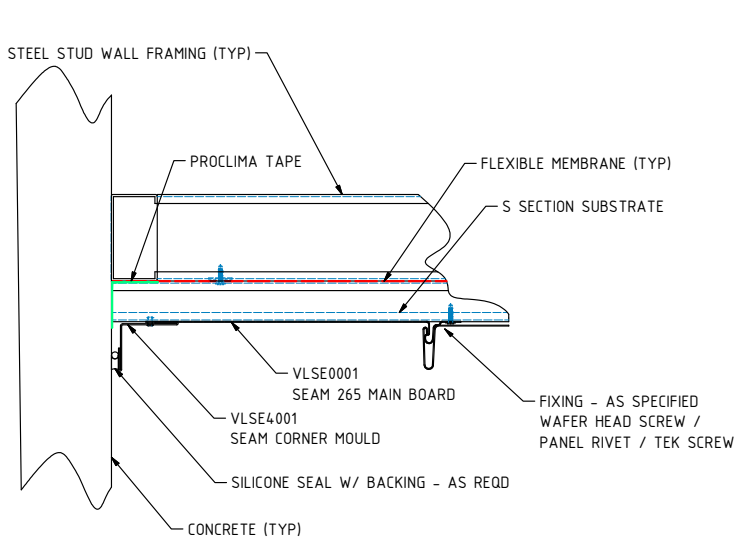

INTERNAL CORNER B

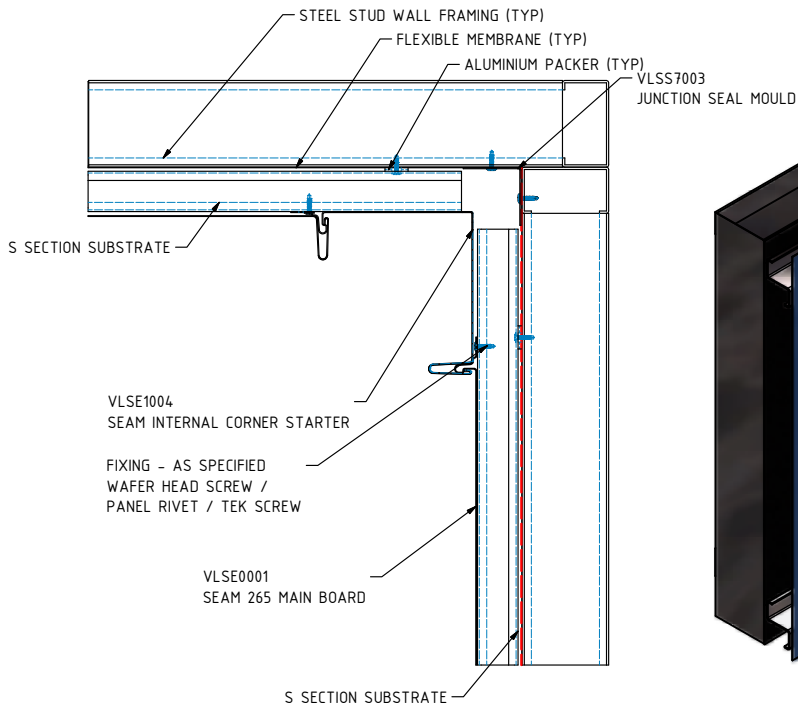

DISCLAIMER: THESE DETAILS ARE LIMITED TO THE GENERALISED DESIGN SPECIFICATION FOR FAIRVIEW VITRALOC, AND ARE INTENDED FOR USE BY A TECHNICALLY SKILLED PERSON ONLY. ANY USE OF THE SAME IS AT THEIR OWN DISCRETION AND RISK. © FVA GROUP PTY. LTD.

INTERNAL CORNER

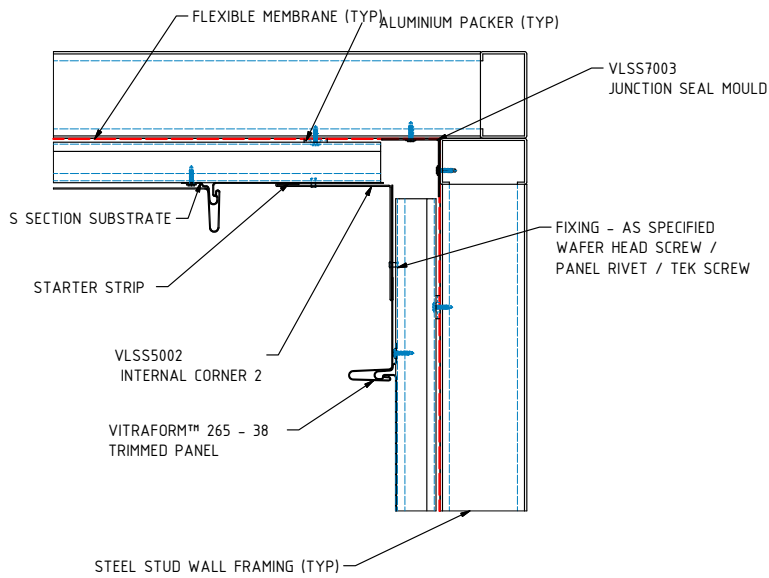

HORIZONTAL EXPANSION JOINT

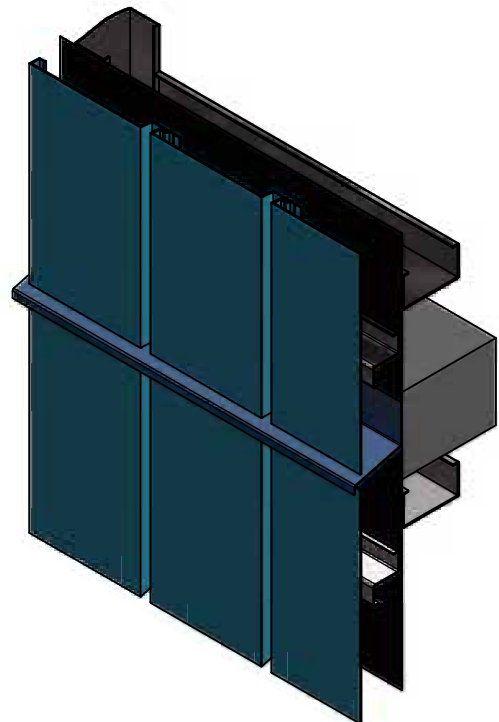
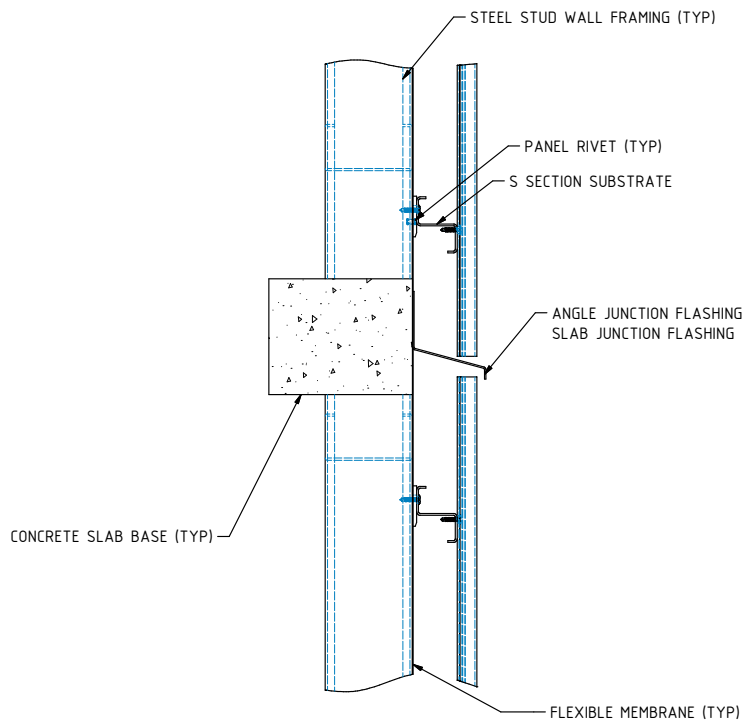

DISCLAIMER: THESE DETAILS ARE LIMITED TO THE GENERALISED DESIGN SPECIFICATION FOR FAIRVIEW VITRALOC, AND ARE INTENDED FOR USE BY A TECHNICALLY SKILLED PERSON ONLY. ANY USE OF THE SAME IS AT THEIR OWN DISCRETION AND RISK. © FVA GROUP PTY. LTD.

EXTERNAL CORNER DETAIL A

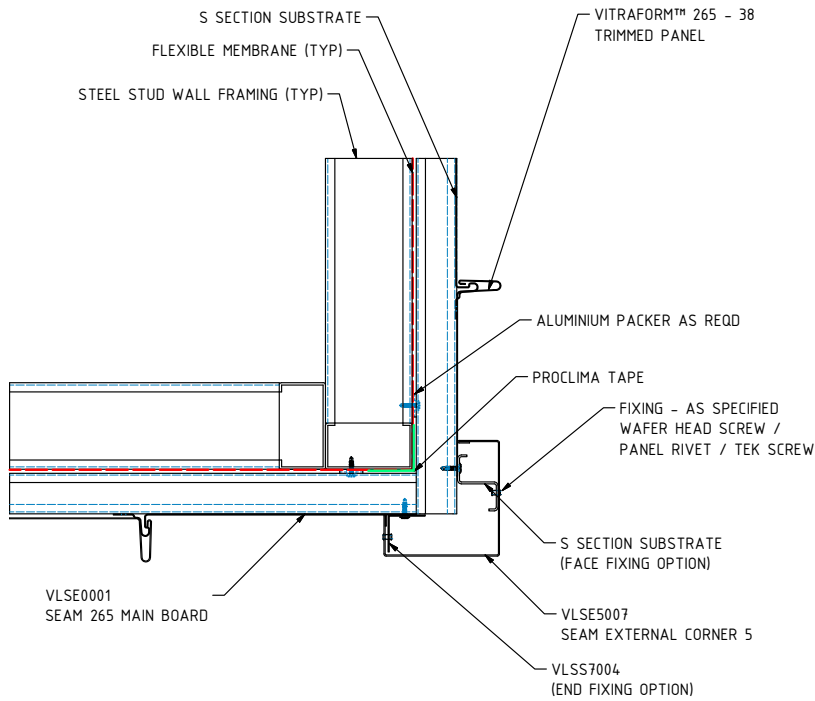

EXTERNAL CORNER DETAIL B

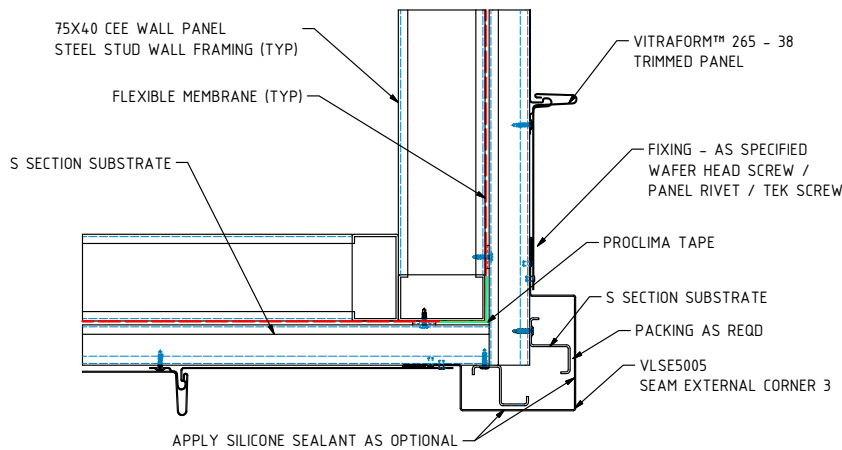

DISCLAIMER: THESE DETAILS ARE LIMITED TO THE GENERALISED DESIGN SPECIFICATION FOR FAIRVIEW VITRALOC, AND ARE INTENDED FOR USE BY A TECHNICALLY SKILLED PERSON ONLY. ANY USE OF THE SAME IS AT THEIR OWN DISCRETION AND RISK. © FVA GROUP PTY. LTD.

EXTERNAL CORNER DETAIL C

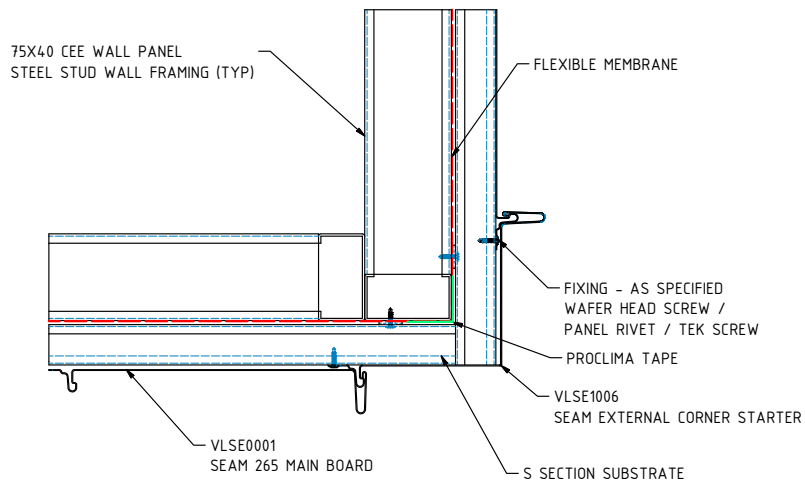

WINDOW HEAD

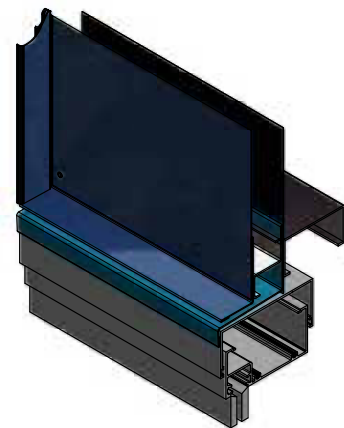
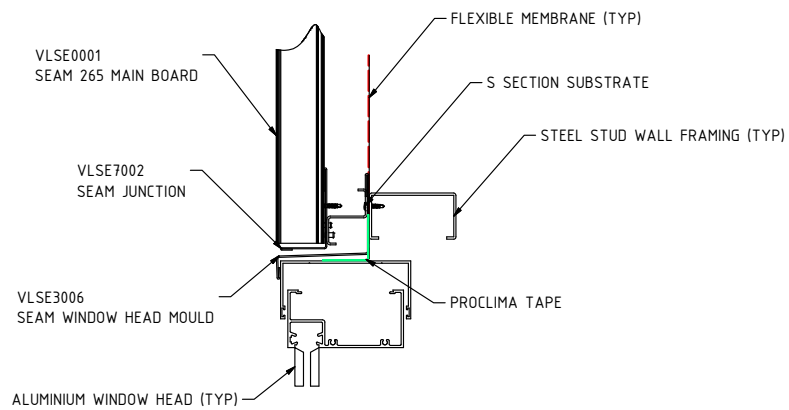

DISCLAIMER: THESE DETAILS ARE LIMITED TO THE GENERALISED DESIGN SPECIFICATION FOR FAIRVIEW VITRALOC, AND ARE INTENDED FOR USE BY A TECHNICALLY SKILLED PERSON ONLY. ANY USE OF THE SAME IS AT THEIR OWN DISCRETION AND RISK. © FVA GROUP PTY. LTD.

WINDOW SILL

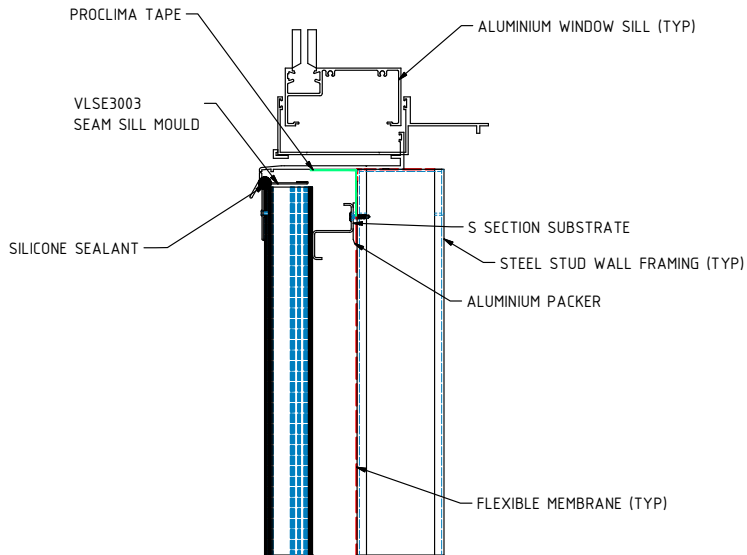

WINDOW JAMB DETAIL A

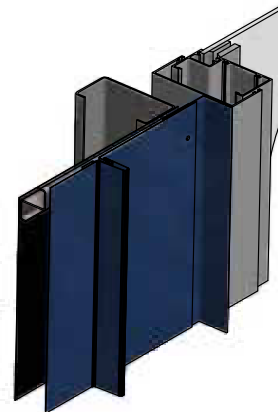
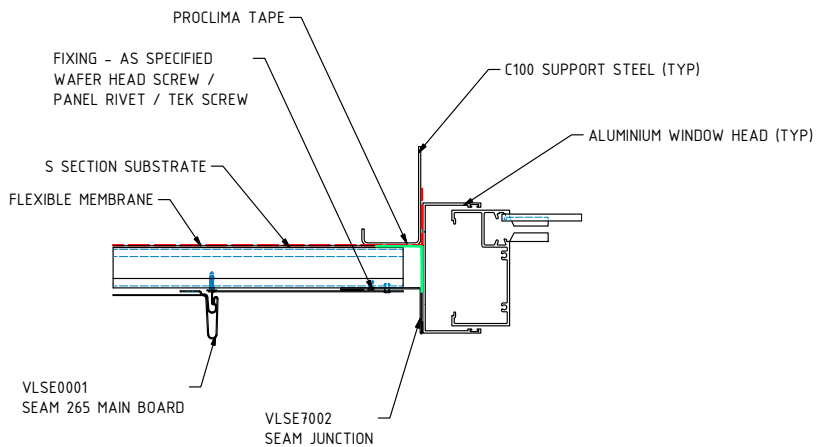

DISCLAIMER: THESE DETAILS ARE LIMITED TO THE GENERALISED DESIGN SPECIFICATION FOR FAIRVIEW VITRALOC, AND ARE INTENDED FOR USE BY A TECHNICALLY SKILLED PERSON ONLY. ANY USE OF THE SAME IS AT THEIR OWN DISCRETION AND RISK. © FVA GROUP PTY. LTD.

WINDOW JAMB DETAIL B1

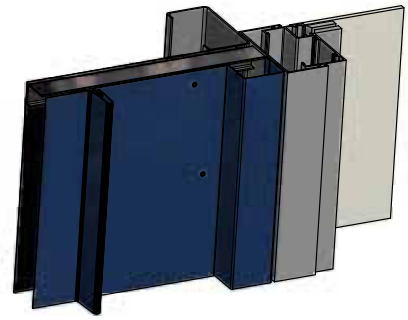
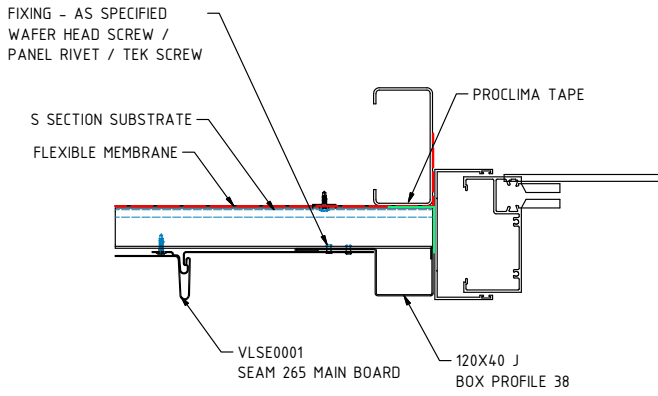

WINDOW JAMB DETAIL B2

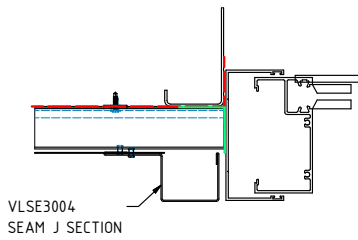

PANEL END DETAIL FLOOR A

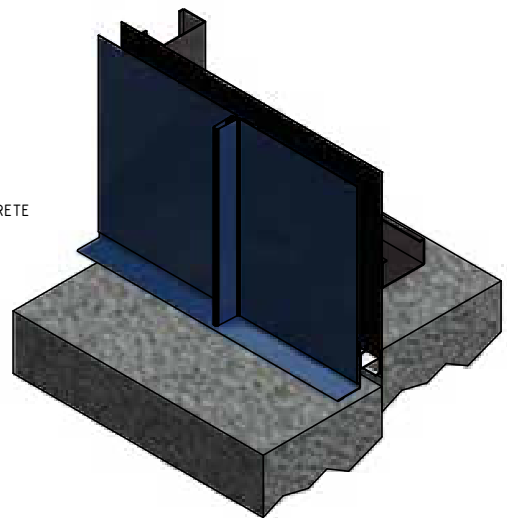
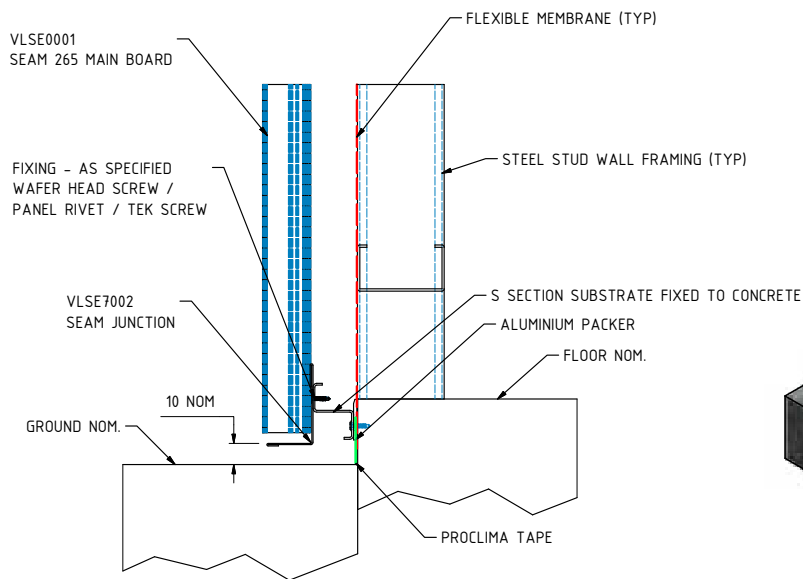

DISCLAIMER: THESE DETAILS ARE LIMITED TO THE GENERALISED DESIGN SPECIFICATION FOR FAIRVIEW VITRALOC, AND ARE INTENDED FOR USE BY A TECHNICALLY SKILLED PERSON ONLY. ANY USE OF THE SAME IS AT THEIR OWN DISCRETION AND RISK. © FVA GROUP PTY. LTD.

PANEL END DETAIL FLOOR B

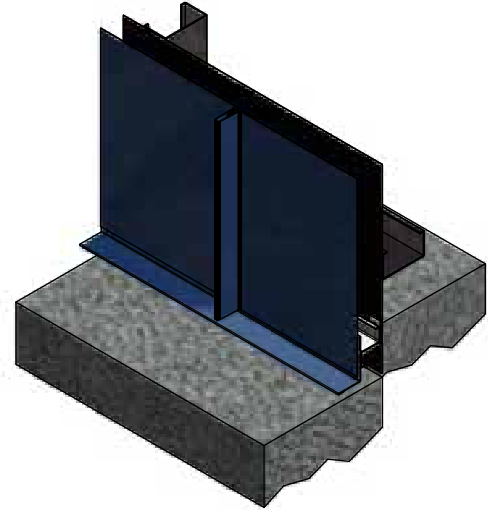
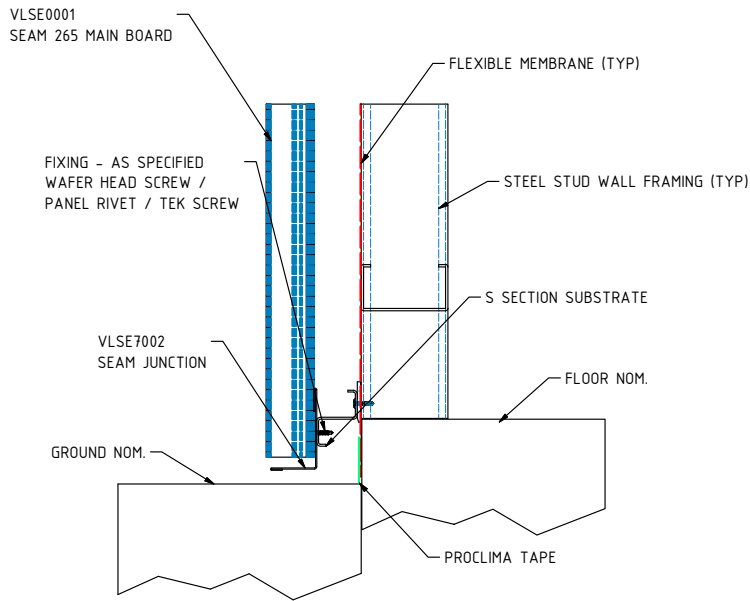

PANEL END DETAIL FLOOR C

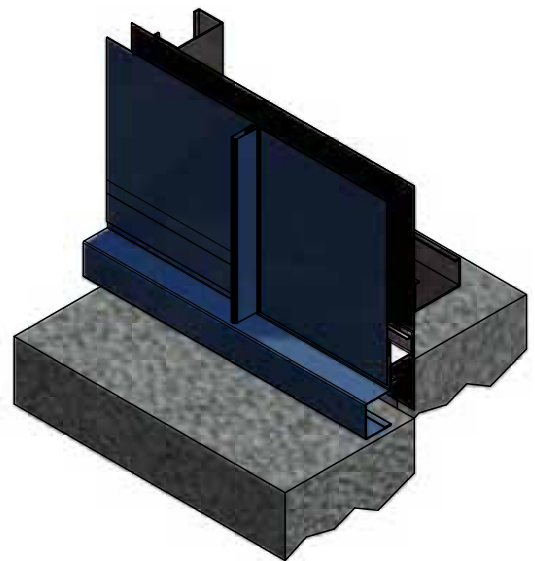
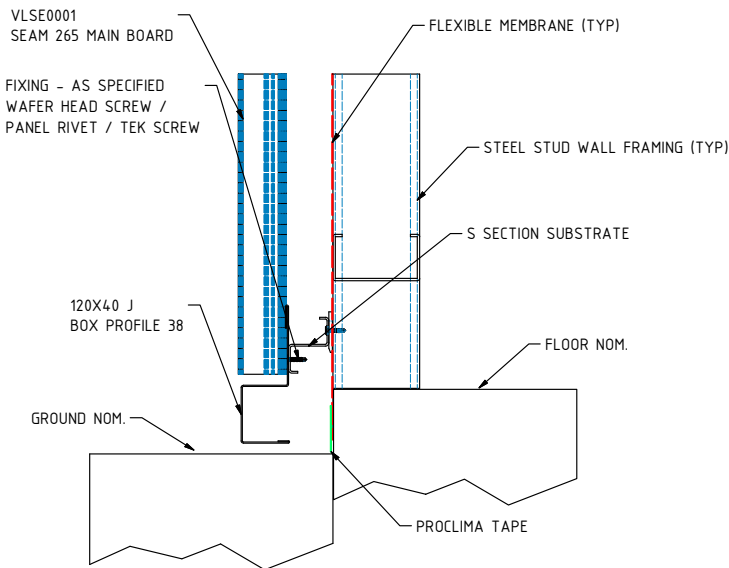

DISCLAIMER: THESE DETAILS ARE LIMITED TO THE GENERALISED DESIGN SPECIFICATION FOR FAIRVIEW VITRALOC, AND ARE INTENDED FOR USE BY A TECHNICALLY SKILLED PERSON ONLY. ANY USE OF THE SAME IS AT THEIR OWN DISCRETION AND RISK. © FVA GROUP PTY. LTD.

SOFFIT JUNCTION A

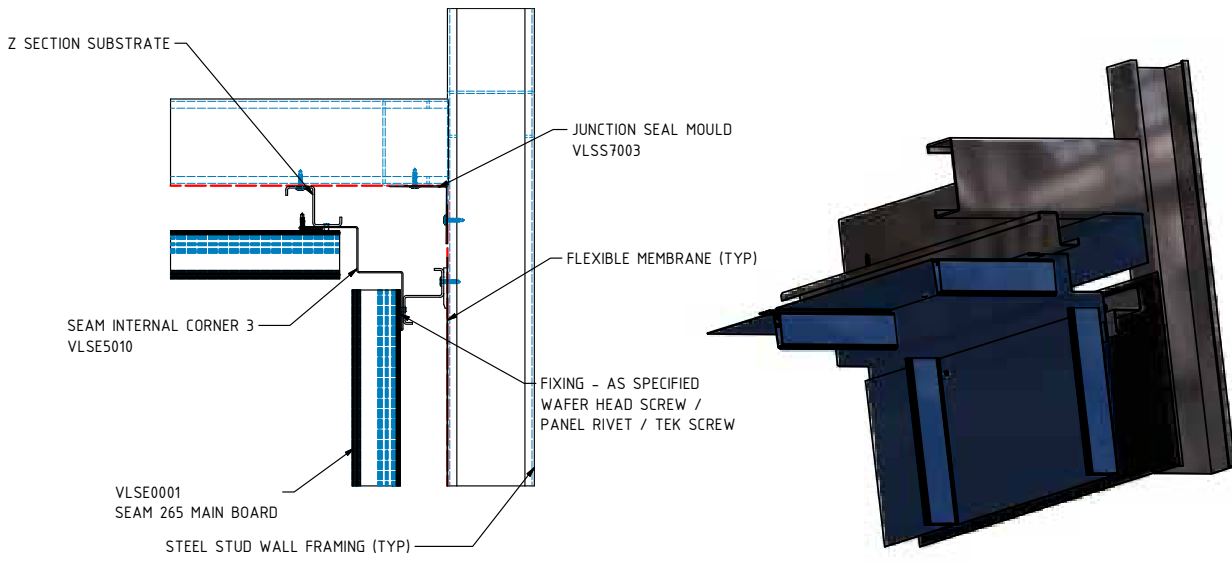

SOFFIT JUNCTION B1

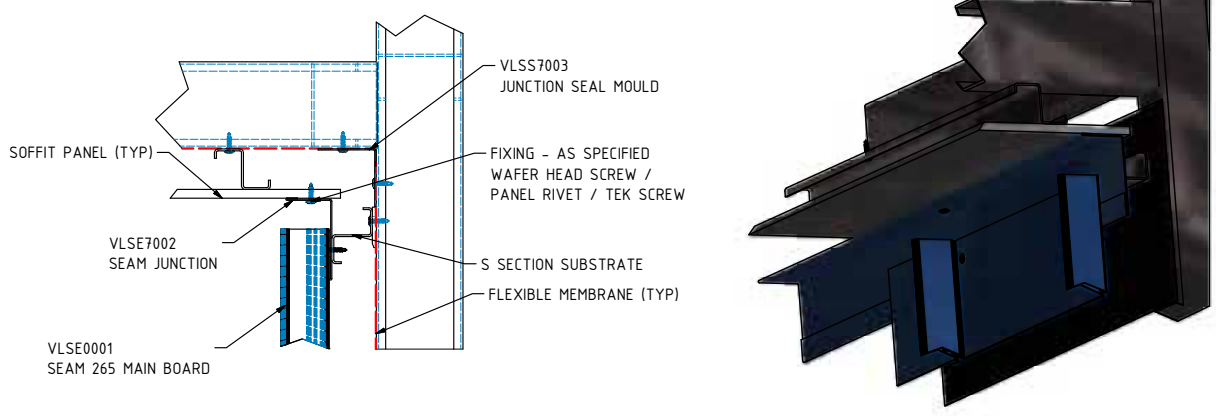

SOFFIT JUNCTION B2

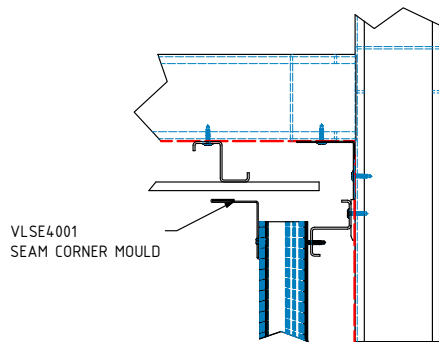

DISCLAIMER: THESE DETAILS ARE LIMITED TO THE GENERALISED DESIGN SPECIFICATION FOR FAIRVIEW VITRALOC, AND ARE INTENDED FOR USE BY A TECHNICALLY SKILLED PERSON ONLY. ANY USE OF THE SAME IS AT THEIR OWN DISCRETION AND RISK. © FVA GROUP PTY. LTD.

SOFFIT JUNCTION C

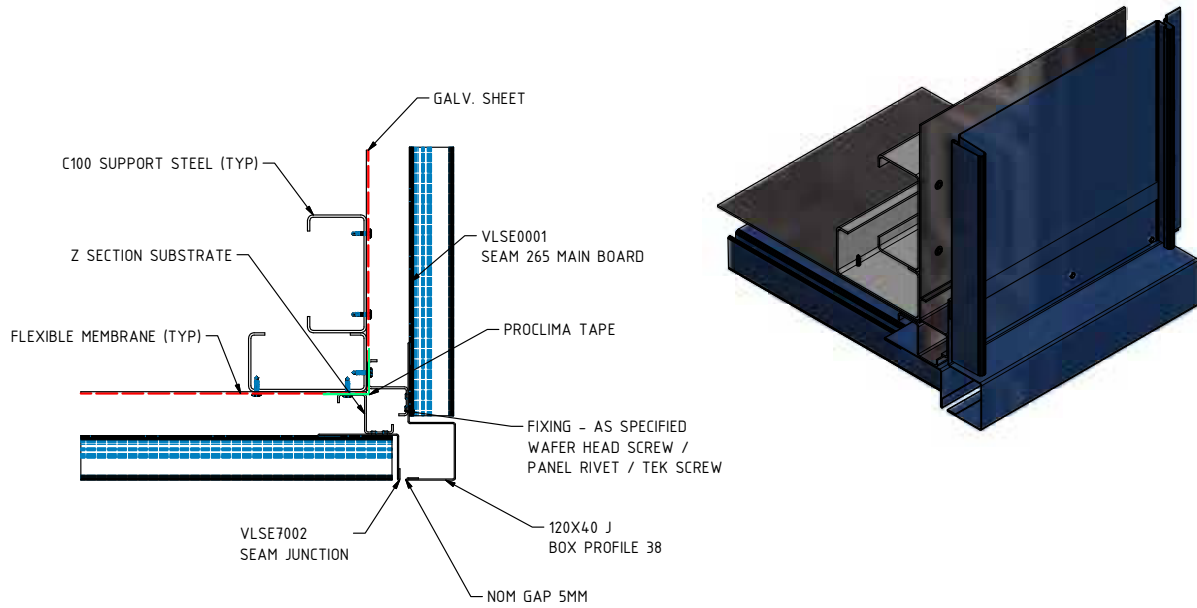

SOFFIT JUNCTION D

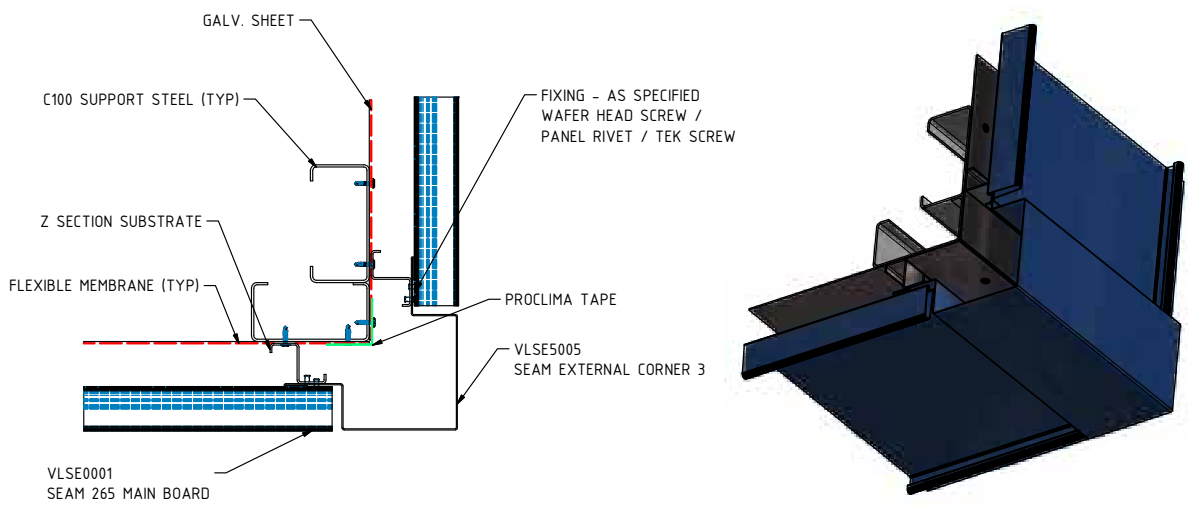

DISCLAIMER: THESE DETAILS ARE LIMITED TO THE GENERALISED DESIGN SPECIFICATION FOR FAIRVIEW VITRALOC, AND ARE INTENDED FOR USE BY A TECHNICALLY SKILLED PERSON ONLY. ANY USE OF THE SAME IS AT THEIR OWN DISCRETION AND RISK. © FVA GROUP PTY. LTD.

SOFFIT JUNCTION E

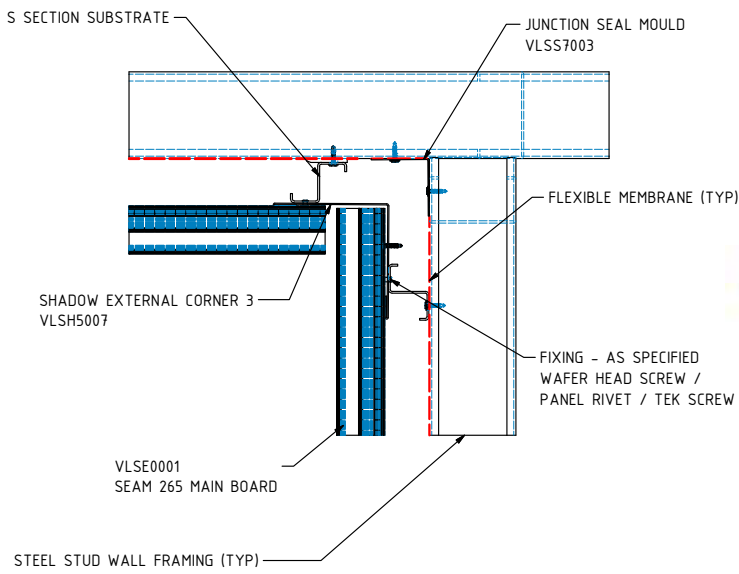

PARAPET AND GUTTER DETAIL A

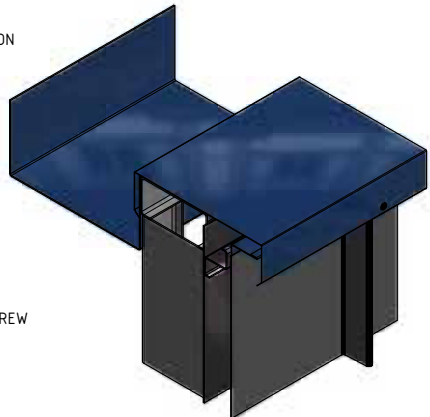
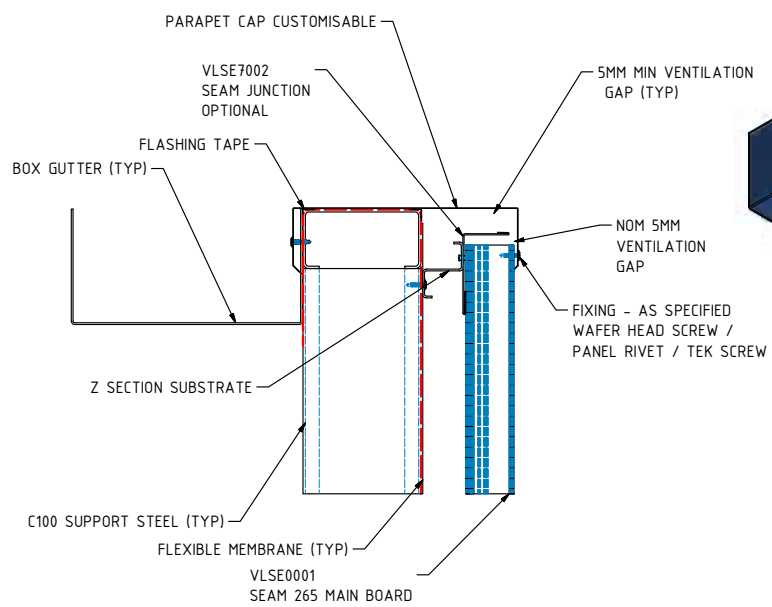

DISCLAIMER: THESE DETAILS ARE LIMITED TO THE GENERALISED DESIGN SPECIFICATION FOR FAIRVIEW VITRALOC, AND ARE INTENDED FOR USE BY A TECHNICALLY SKILLED PERSON ONLY. ANY USE OF THE SAME IS AT THEIR OWN DISCRETION AND RISK. © FVA GROUP PTY. LTD.

PARAPET AND GUTTER DETAIL B

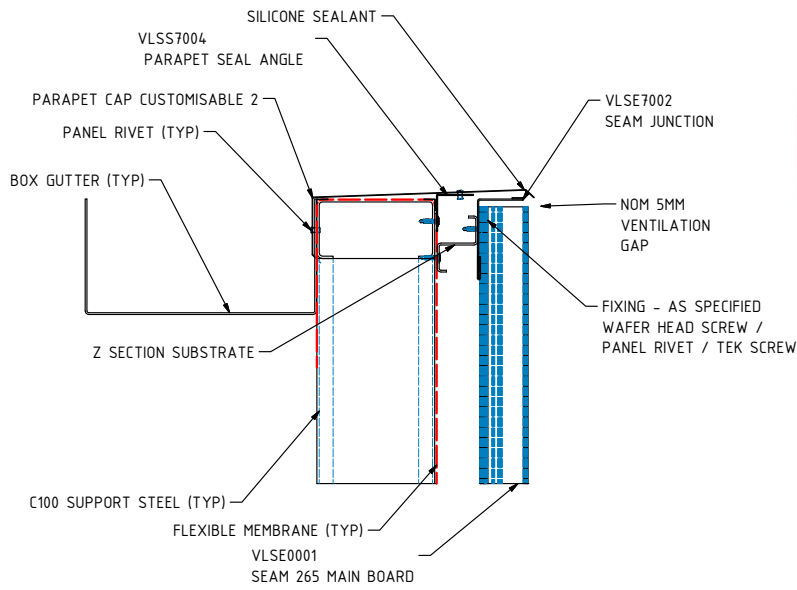

SLAB JUNCTION A

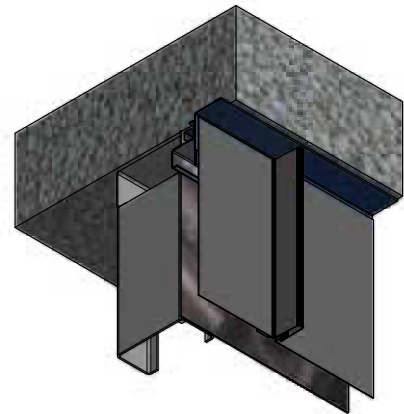
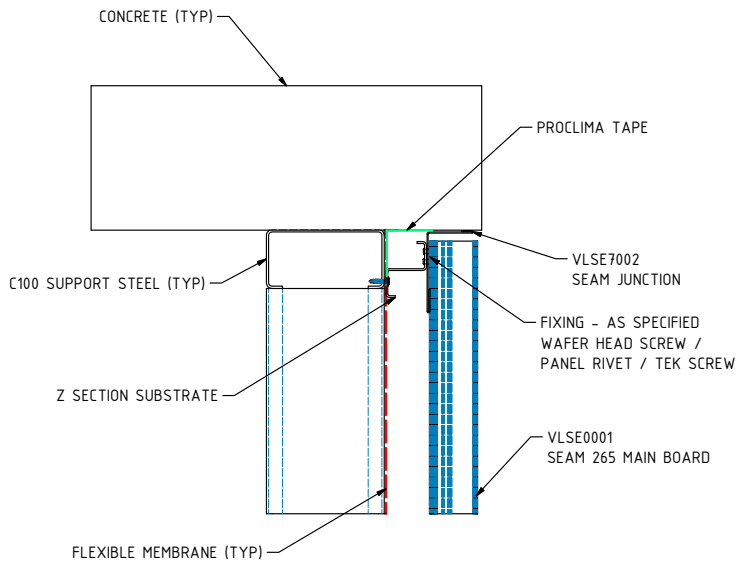

DISCLAIMER: THESE DETAILS ARE LIMITED TO THE GENERALISED DESIGN SPECIFICATION FOR FAIRVIEW VITRALOC, AND ARE INTENDED FOR USE BY A TECHNICALLY SKILLED PERSON ONLY. ANY USE OF THE SAME IS AT THEIR OWN DISCRETION AND RISK. © FVA GROUP PTY. LTD.

SLAB JUNCTION B

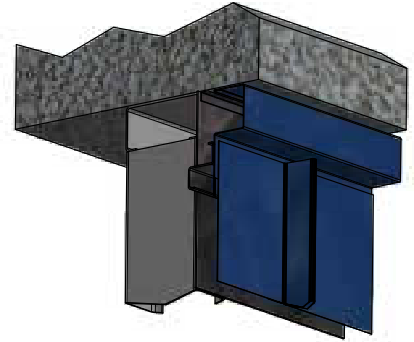
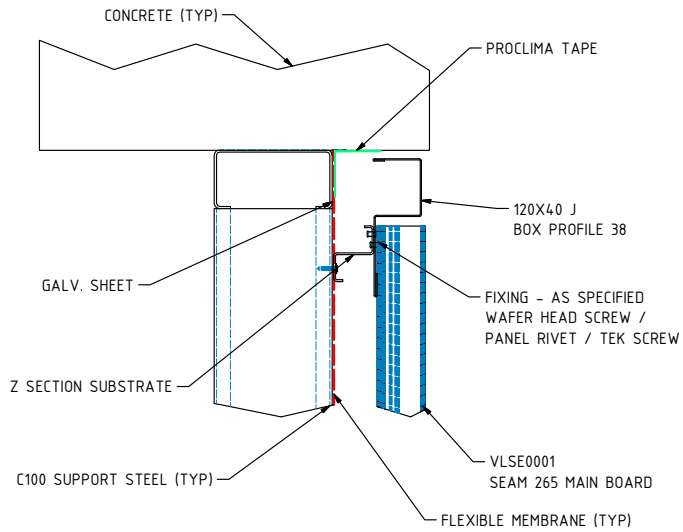

SLAB JUNCTION C1

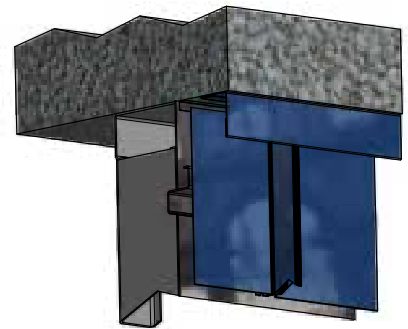
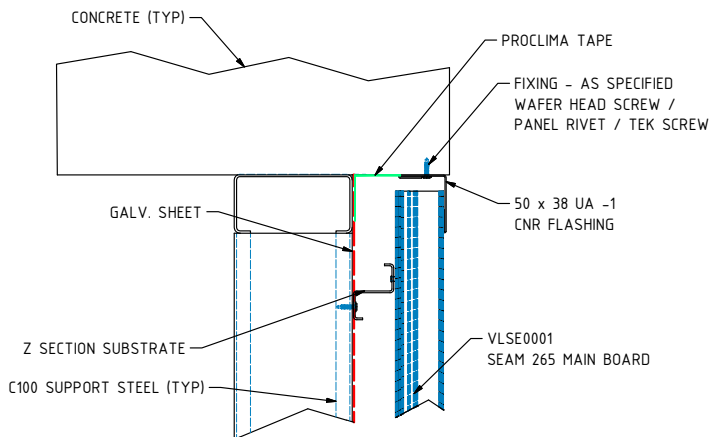

SLAB JUNCTION C2

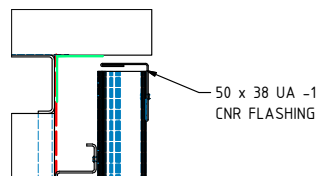

DISCLAIMER: THESE DETAILS ARE LIMITED TO THE GENERALISED DESIGN SPECIFICATION FOR FAIRVIEW VITRALOC, AND ARE INTENDED FOR USE BY A TECHNICALLY SKILLED PERSON ONLY. ANY USE OF THE SAME IS AT THEIR OWN DISCRETION AND RISK. © FVA GROUP PTY. LTD.

SEAM HORIZONTAL PANEL CONNECTION DETAIL

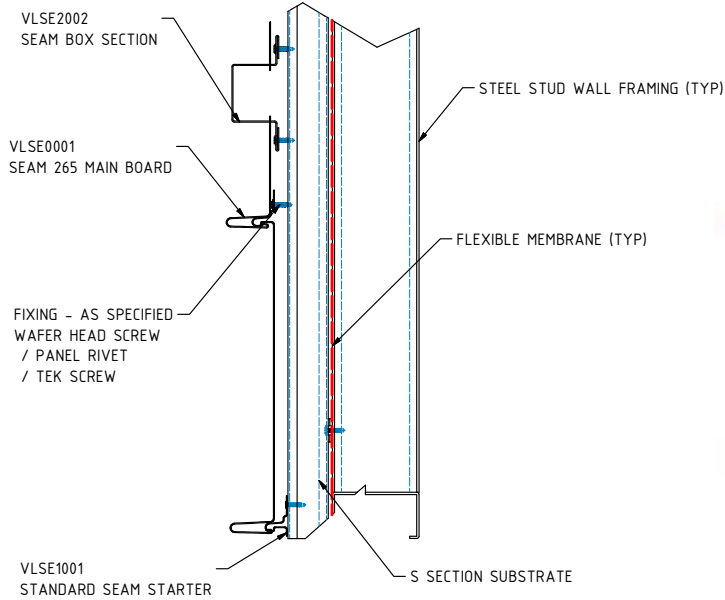

HORIZONTAL EXPANSION JOINT A

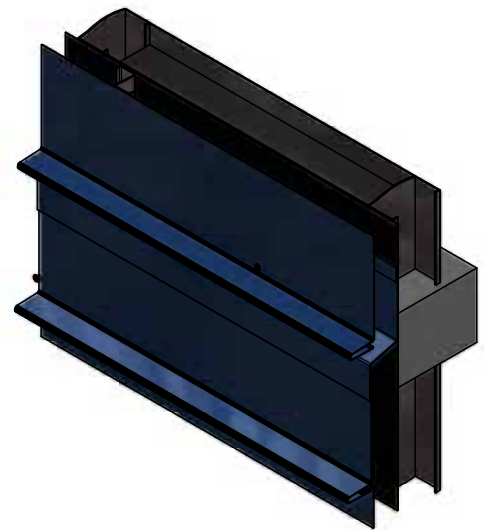
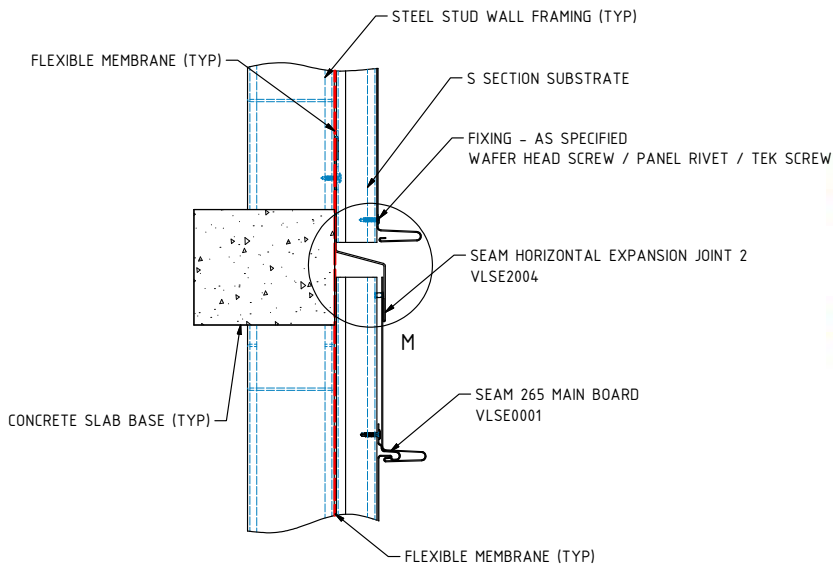

DISCLAIMER: THESE DETAILS ARE LIMITED TO THE GENERALISED DESIGN SPECIFICATION FOR FAIRVIEW VITRALOC, AND ARE INTENDED FOR USE BY A TECHNICALLY SKILLED PERSON ONLY. ANY USE OF THE SAME IS AT THEIR OWN DISCRETION AND RISK. © FVA GROUP PTY. LTD.

HORIZONTAL EXPANSION JOINT B

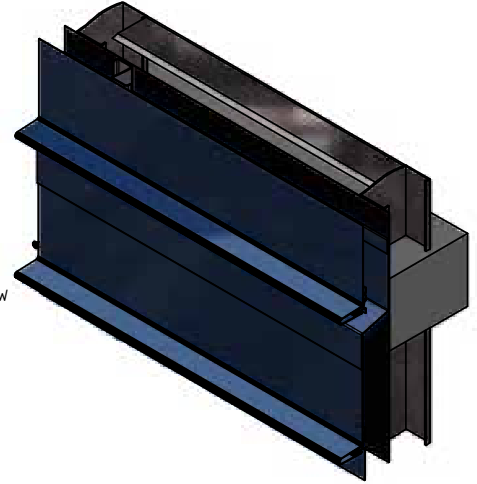
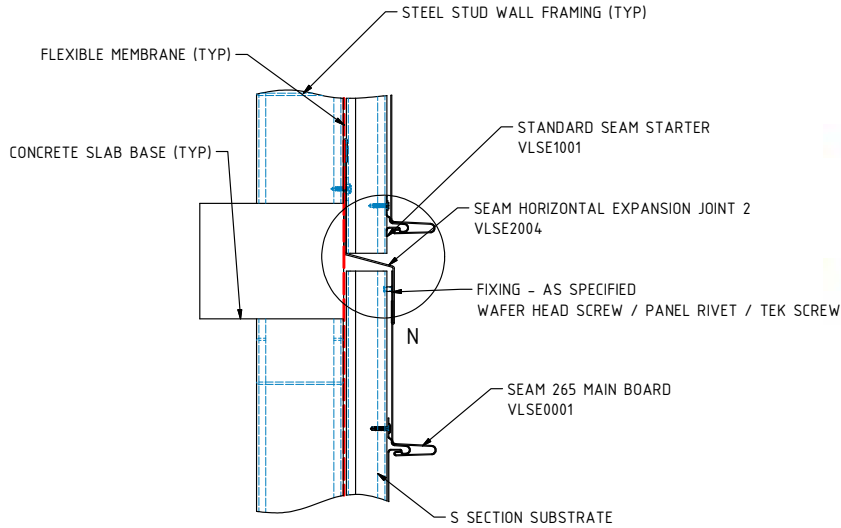

HORIZONTAL EXPANSION JOINT C

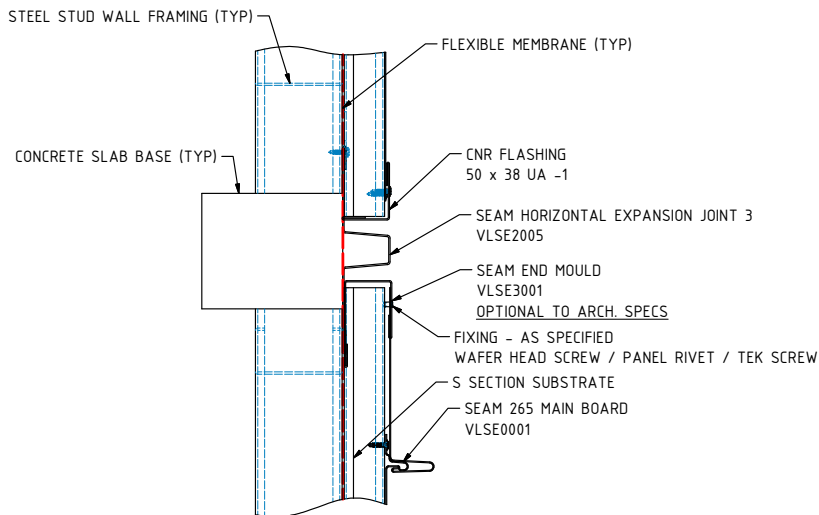

DISCLAIMER: THESE DETAILS ARE LIMITED TO THE GENERALISED DESIGN SPECIFICATION FOR FAIRVIEW VITRALOC, AND ARE INTENDED FOR USE BY A TECHNICALLY SKILLED PERSON ONLY. ANY USE OF THE SAME IS AT THEIR OWN DISCRETION AND RISK. © FVA GROUP PTY. LTD.

WALL JUNCTION A

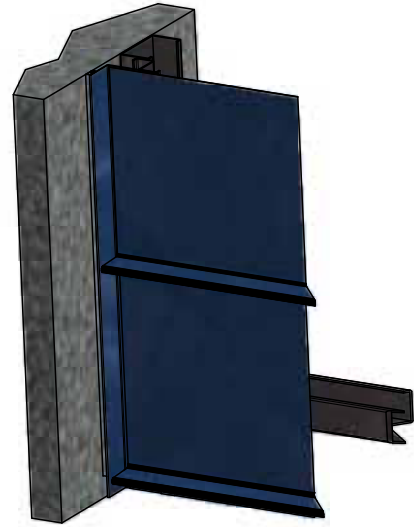
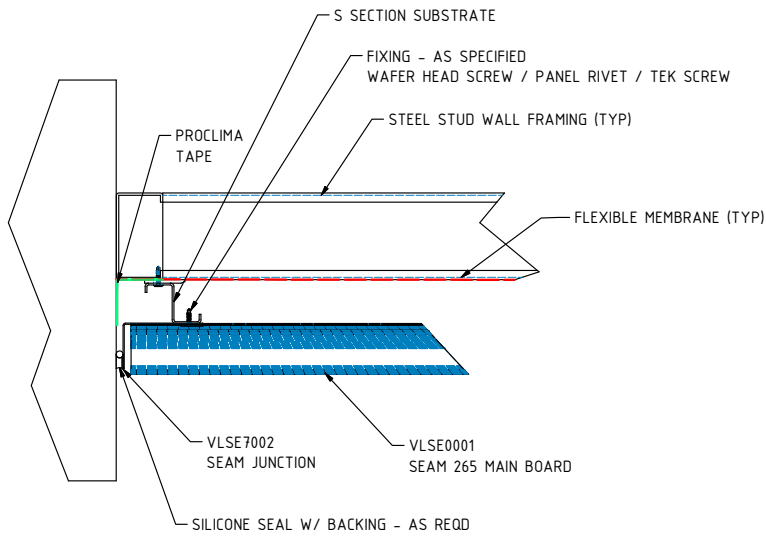

WALL JUNCTION B

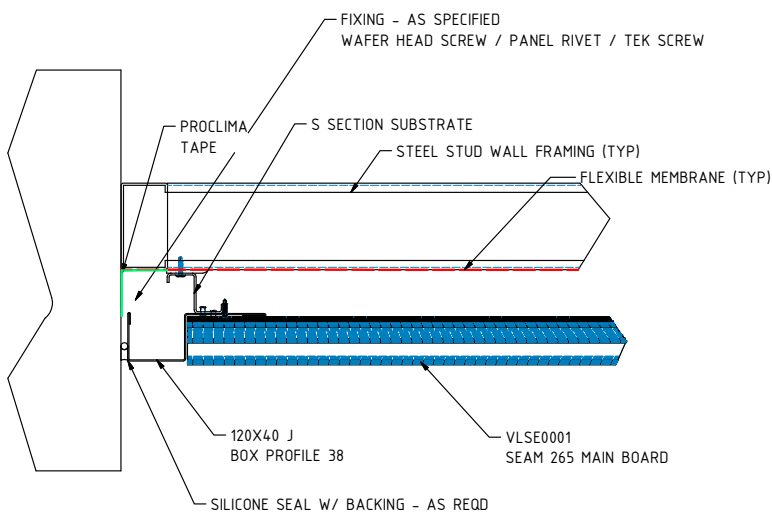

DISCLAIMER: THESE DETAILS ARE LIMITED TO THE GENERALISED DESIGN SPECIFICATION FOR FAIRVIEW VITRALOC, AND ARE INTENDED FOR USE BY A TECHNICALLY SKILLED PERSON ONLY. ANY USE OF THE SAME IS AT THEIR OWN DISCRETION AND RISK. © FVA GROUP PTY. LTD.

INTERNAL CORNER DETAIL

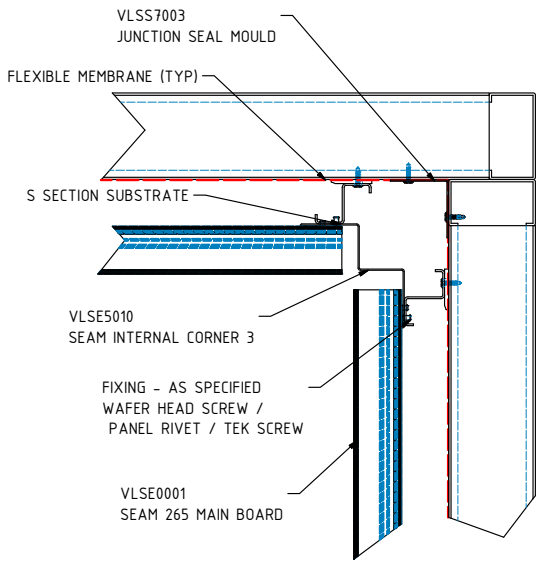

INTERNAL CORNER DETAIL

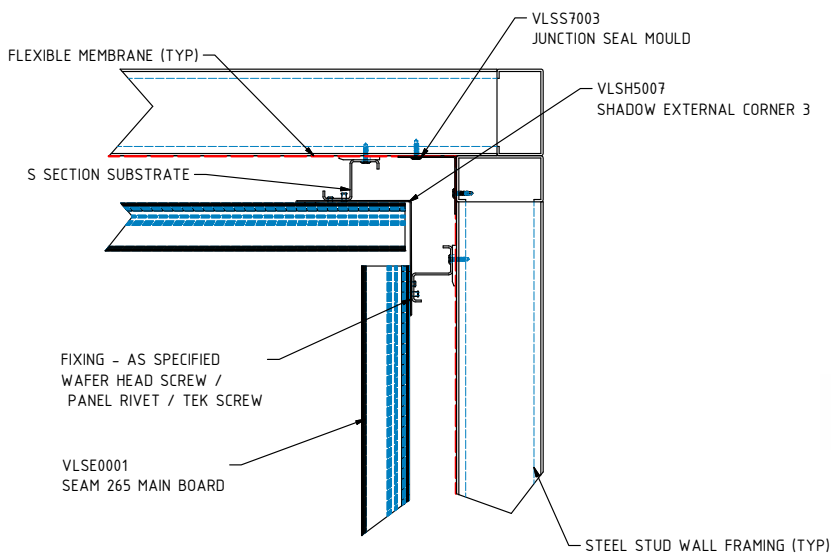

DISCLAIMER: THESE DETAILS ARE LIMITED TO THE GENERALISED DESIGN SPECIFICATION FOR FAIRVIEW VITRALOC, AND ARE INTENDED FOR USE BY A TECHNICALLY SKILLED PERSON ONLY. ANY USE OF THE SAME IS AT THEIR OWN DISCRETION AND RISK. © FVA GROUP PTY. LTD.

EXTERNAL CORNER DETAIL A

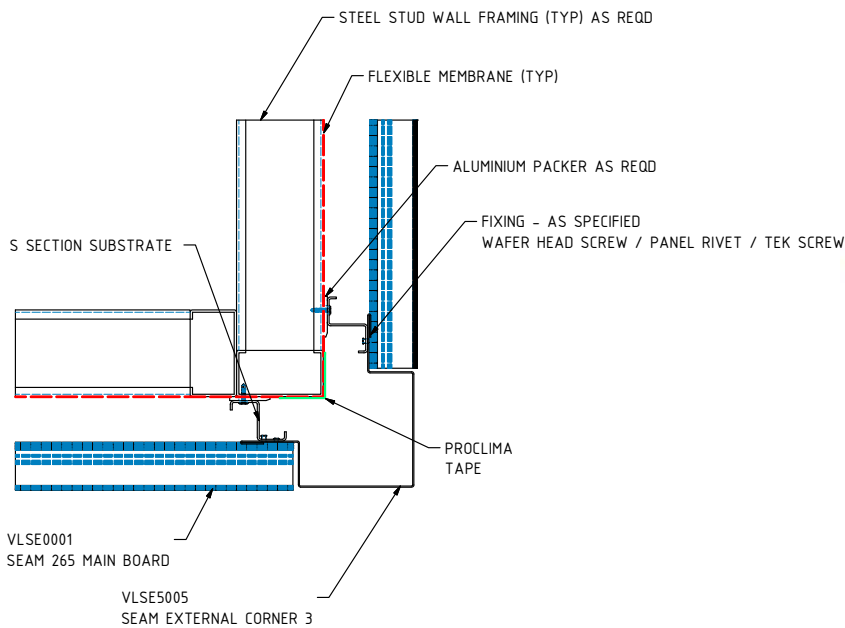

WINDOW HEAD

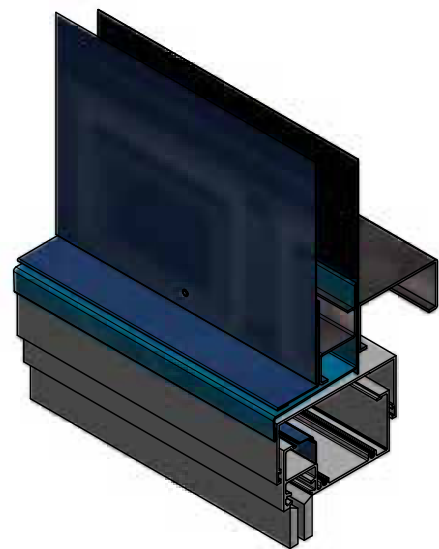
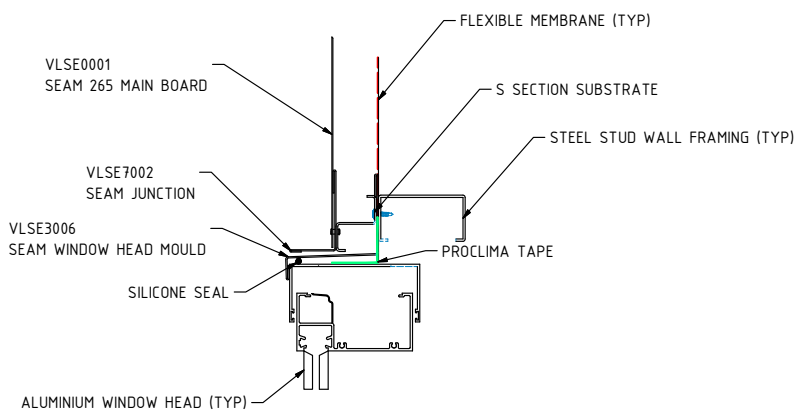

DISCLAIMER: THESE DETAILS ARE LIMITED TO THE GENERALISED DESIGN SPECIFICATION FOR FAIRVIEW VITRALOC, AND ARE INTENDED FOR USE BY A TECHNICALLY SKILLED PERSON ONLY. ANY USE OF THE SAME IS AT THEIR OWN DISCRETION AND RISK. © FVA GROUP PTY. LTD.

WINDOW HEAD B

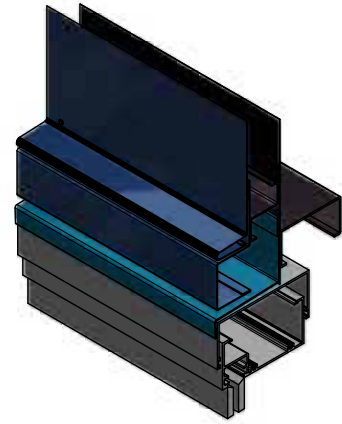
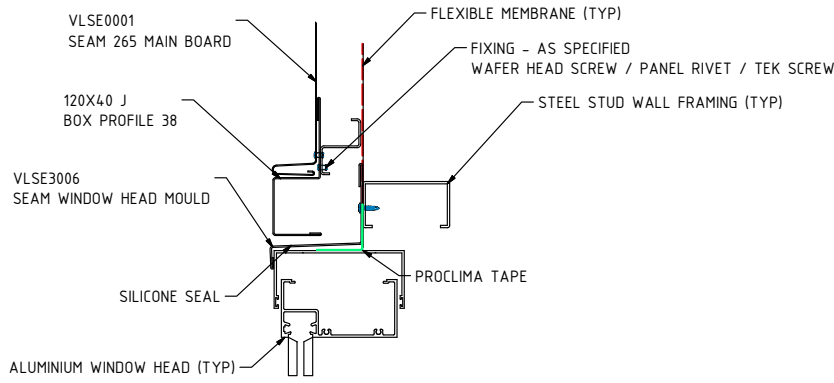

WINDOW SILL 'A'

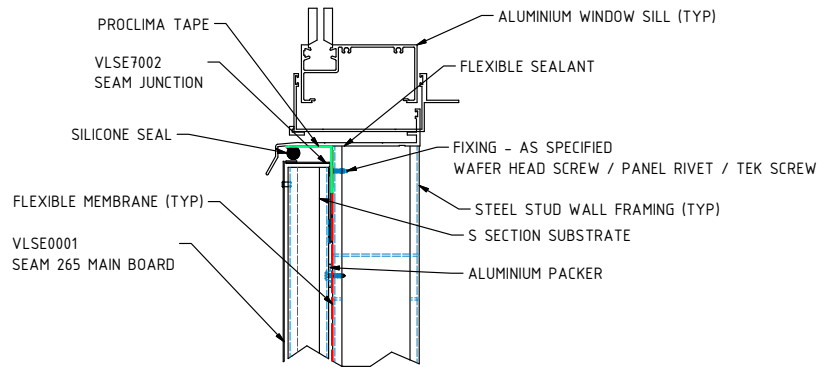

WINDOW SILL 'B'

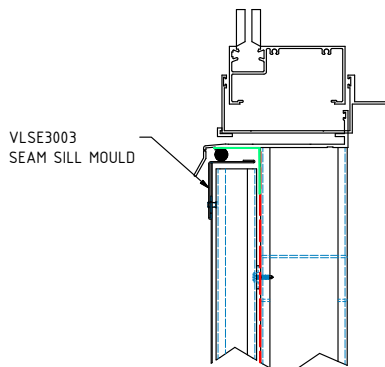

DISCLAIMER: THESE DETAILS ARE LIMITED TO THE GENERALISED DESIGN SPECIFICATION FOR FAIRVIEW VITRALOC, AND ARE INTENDED FOR USE BY A TECHNICALLY SKILLED PERSON ONLY. ANY USE OF THE SAME IS AT THEIR OWN DISCRETION AND RISK. © FVA GROUP PTY. LTD.

WINDOW SILL B

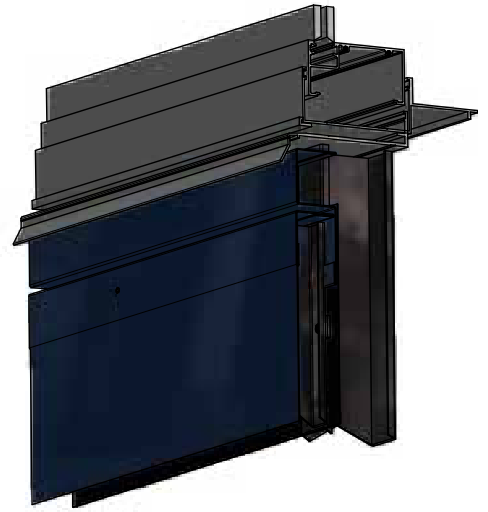
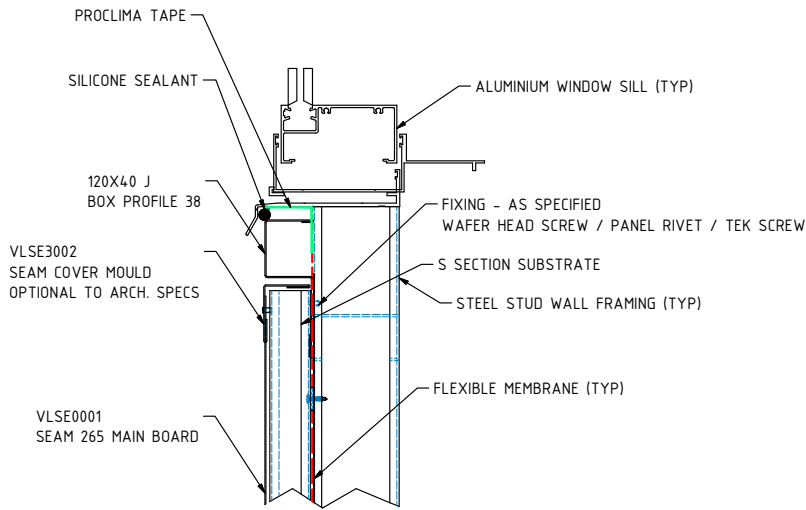

WINDOW JAMB DETAIL A

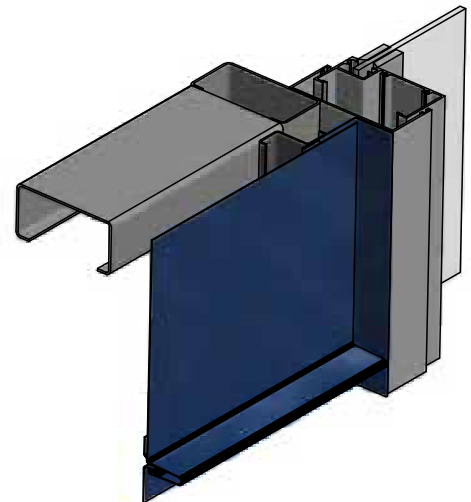
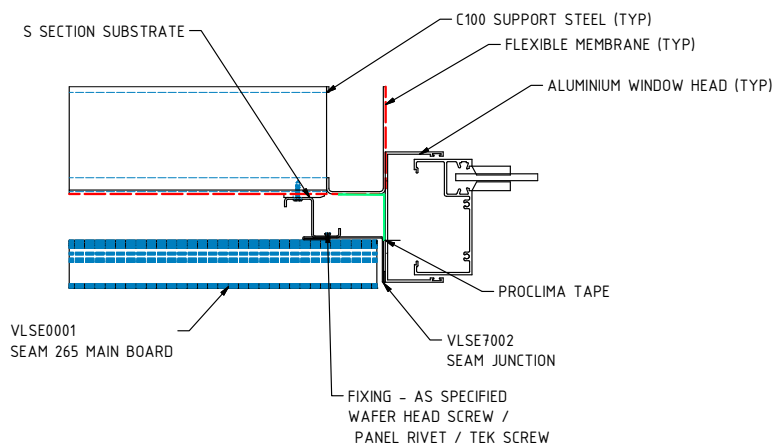

DISCLAIMER: THESE DETAILS ARE LIMITED TO THE GENERALISED DESIGN SPECIFICATION FOR FAIRVIEW VITRALOC, AND ARE INTENDED FOR USE BY A TECHNICALLY SKILLED PERSON ONLY. ANY USE OF THE SAME IS AT THEIR OWN DISCRETION AND RISK. © FVA GROUP PTY. LTD.

OPTIONAL FLASHING

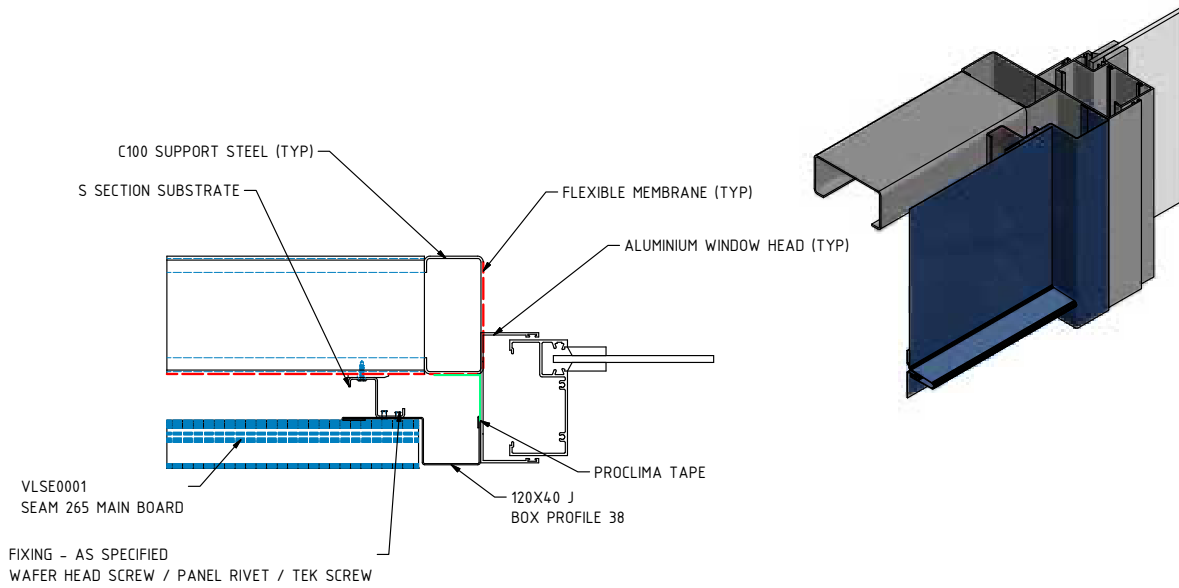

PANEL END DETAIL FLOOR A

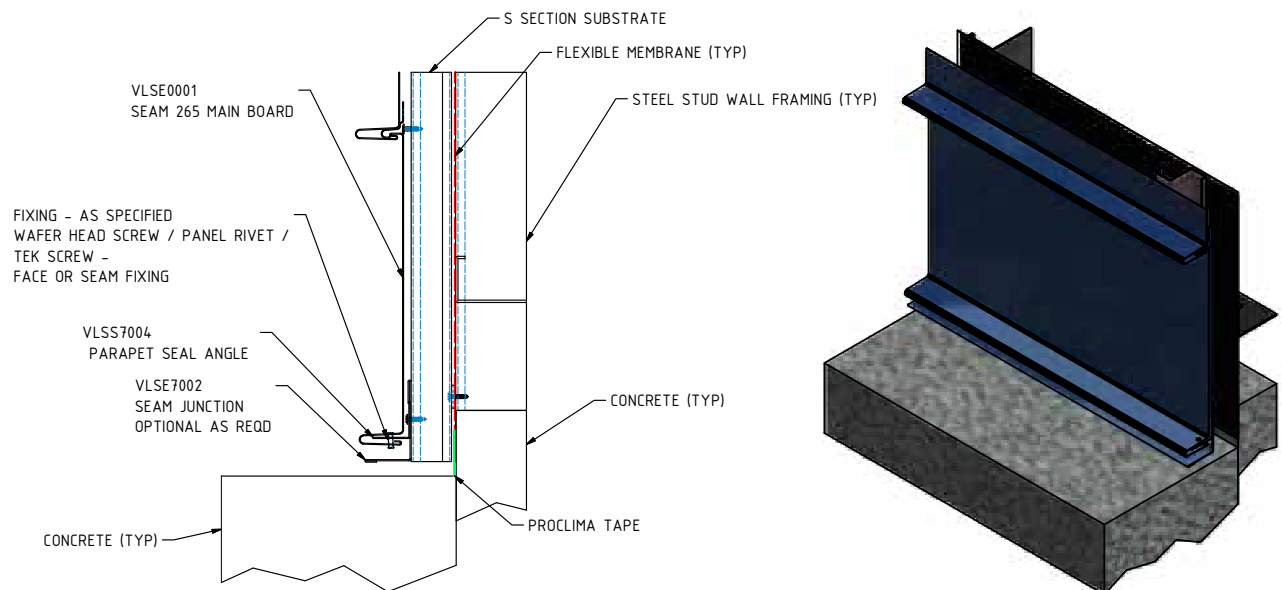

DISCLAIMER: THESE DETAILS ARE LIMITED TO THE GENERALISED DESIGN SPECIFICATION FOR FAIRVIEW VITRALOC, AND ARE INTENDED FOR USE BY A TECHNICALLY SKILLED PERSON ONLY. ANY USE OF THE SAME IS AT THEIR OWN DISCRETION AND RISK. © FVA GROUP PTY. LTD.

PANEL END DETAIL FLOOR B

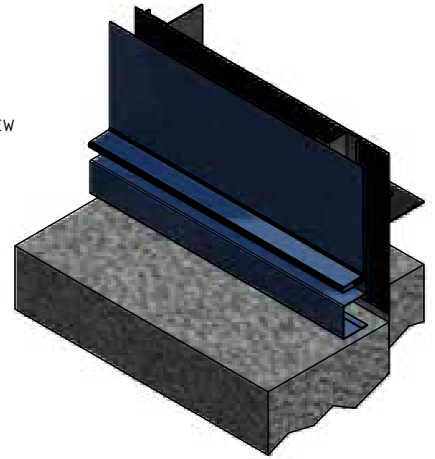
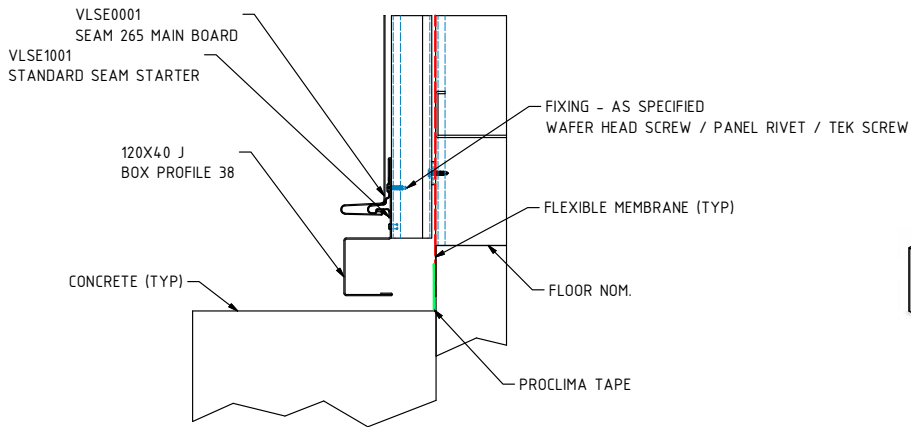

PANEL END DETAIL FLOOR C

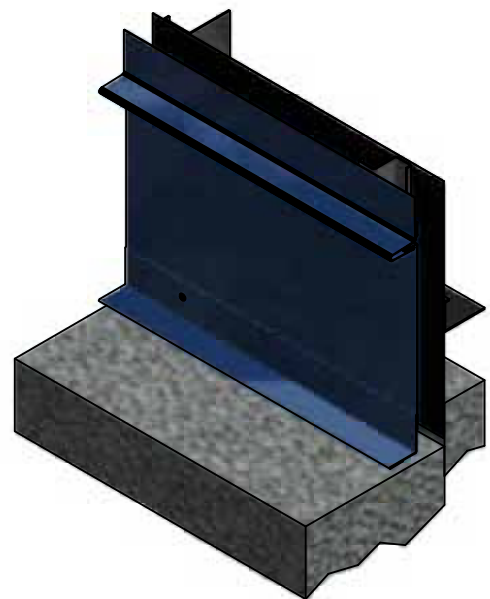
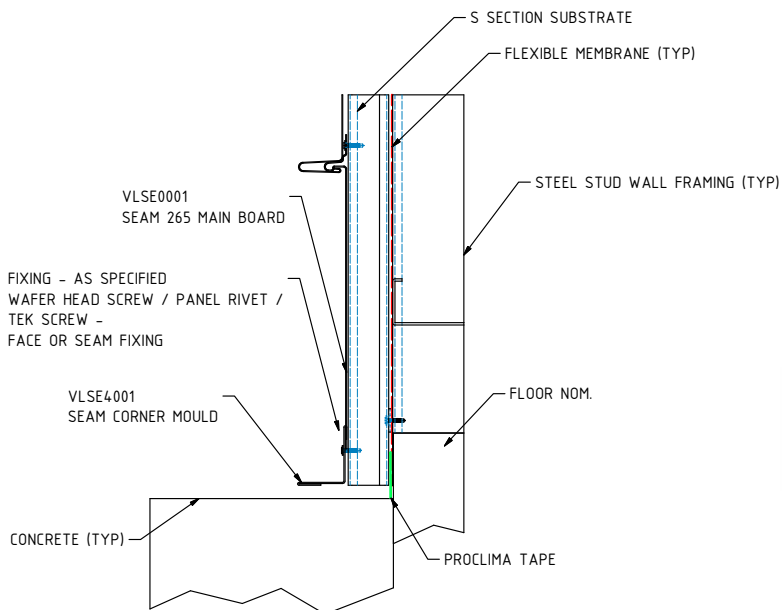

DISCLAIMER: THESE DETAILS ARE LIMITED TO THE GENERALISED DESIGN SPECIFICATION FOR FAIRVIEW VITRALOC, AND ARE INTENDED FOR USE BY A TECHNICALLY SKILLED PERSON ONLY. ANY USE OF THE SAME IS AT THEIR OWN DISCRETION AND RISK. © FVA GROUP PTY. LTD.

PANEL END DETAIL FLOOR D

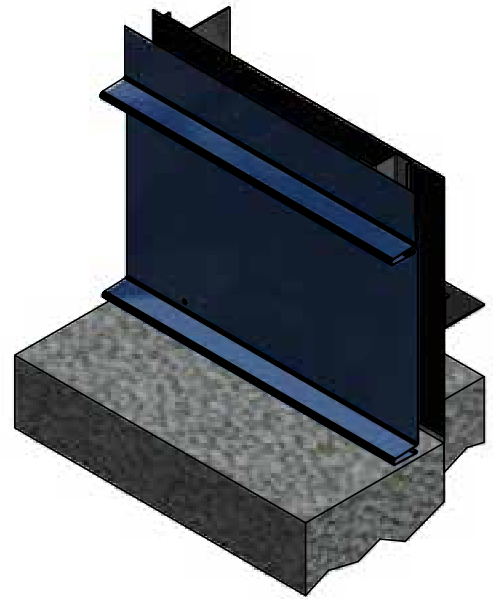
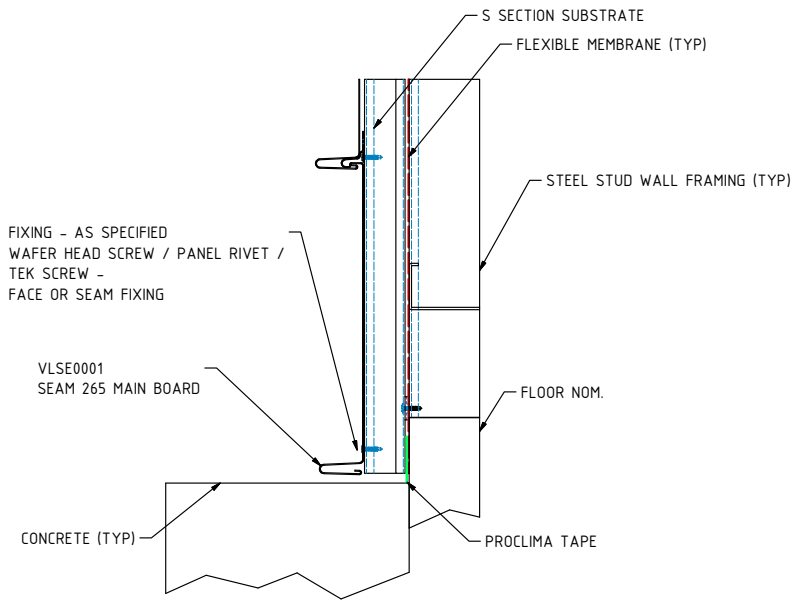

SOFFIT A

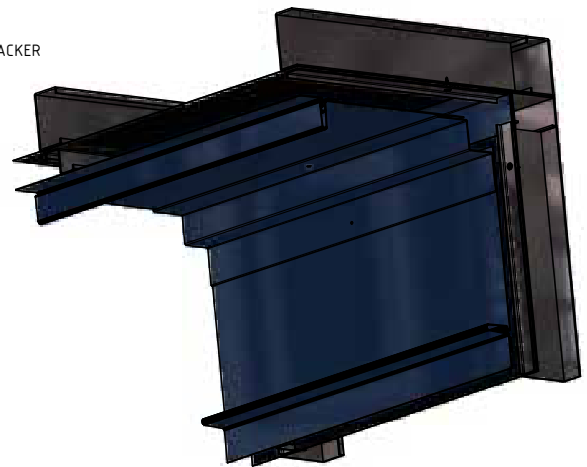
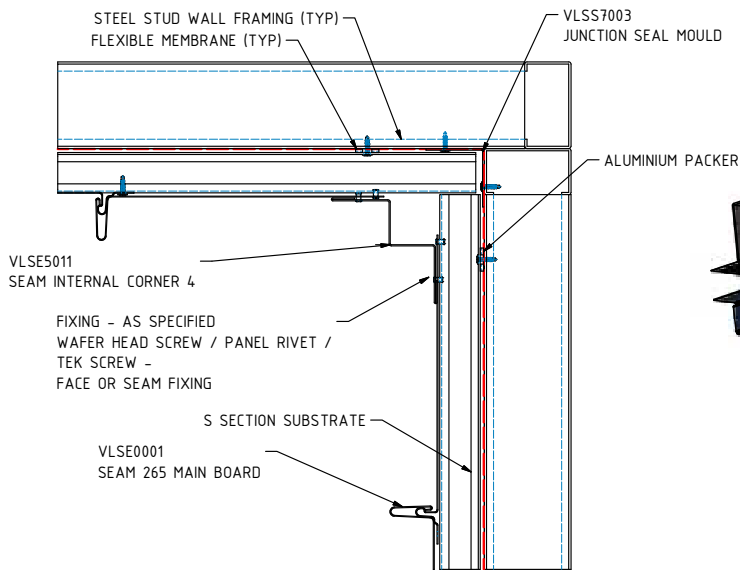

DISCLAIMER: THESE DETAILS ARE LIMITED TO THE GENERALISED DESIGN SPECIFICATION FOR FAIRVIEW VITRALOC, AND ARE INTENDED FOR USE BY A TECHNICALLY SKILLED PERSON ONLY. ANY USE OF THE SAME IS AT THEIR OWN DISCRETION AND RISK. © FVA GROUP PTY. LTD.

SOFFIT JUNCTION B1

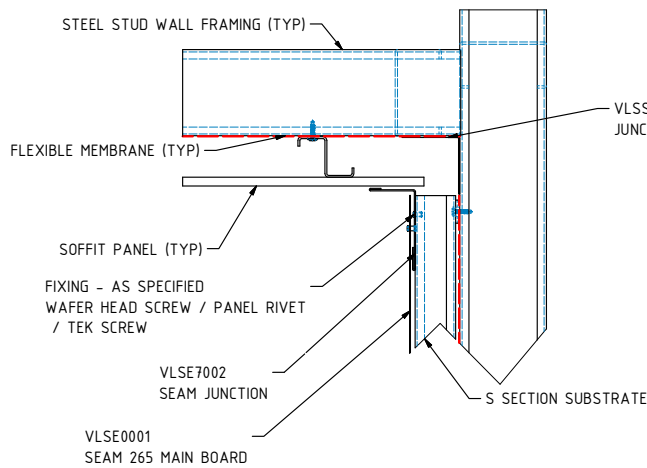

SOFFIT JUNCTION B2

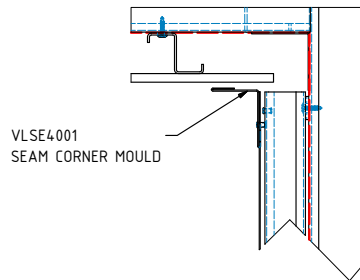

SOFFIT C

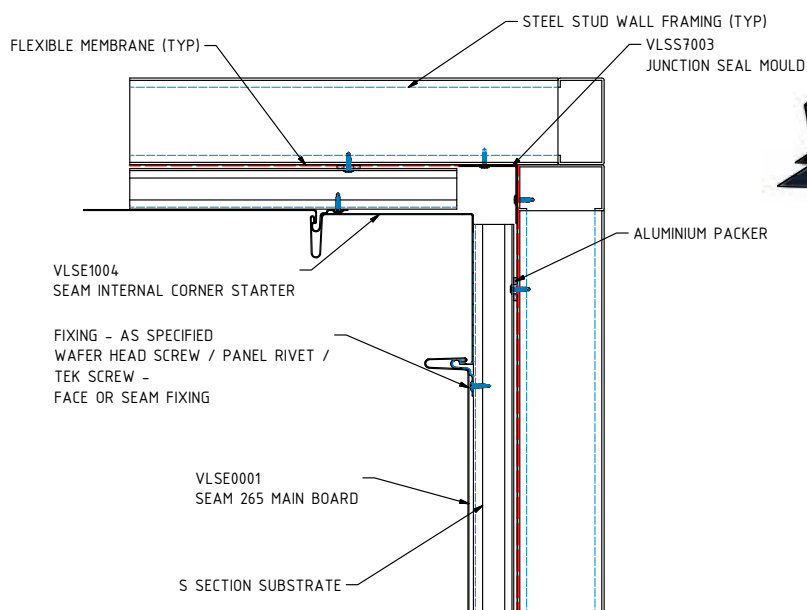

DISCLAIMER: THESE DETAILS ARE LIMITED TO THE GENERALISED DESIGN SPECIFICATION FOR FAIRVIEW VITRALOC, AND ARE INTENDED FOR USE BY A TECHNICALLY SKILLED PERSON ONLY. ANY USE OF THE SAME IS AT THEIR OWN DISCRETION AND RISK. © FVA GROUP PTY. LTD.

SOFFIT EXTERNAL CNR - WITH DRAINAGE

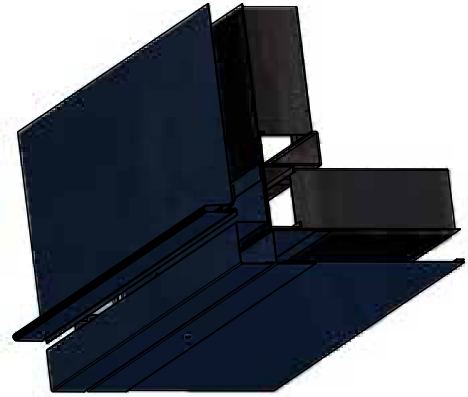
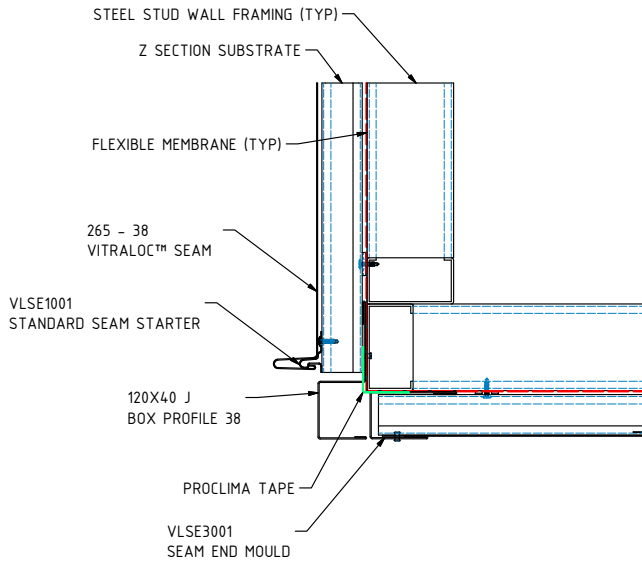

SOFFIT D

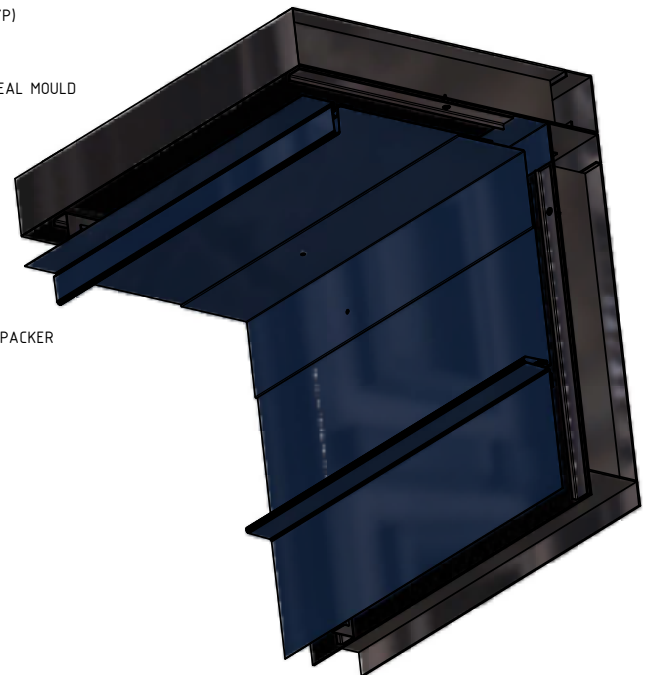
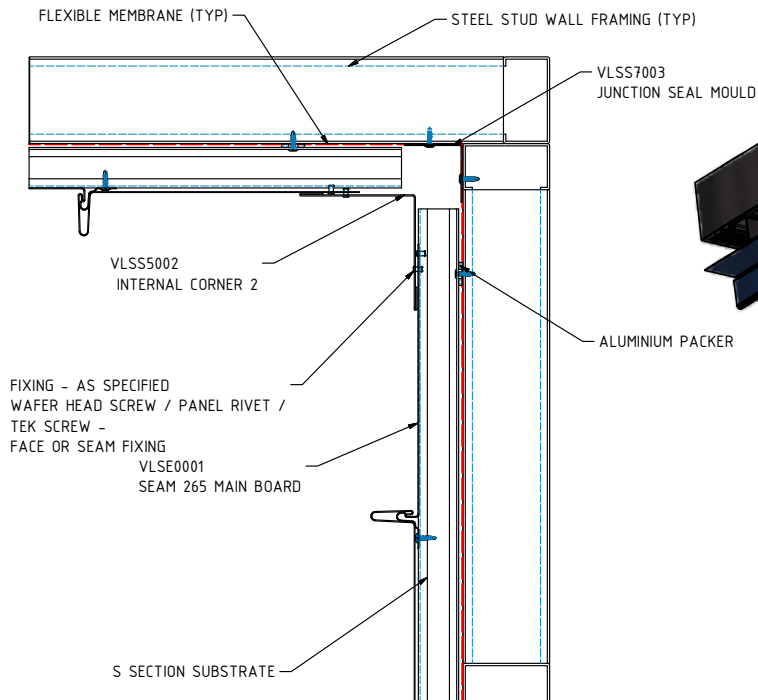

DISCLAIMER: THESE DETAILS ARE LIMITED TO THE GENERALISED DESIGN SPECIFICATION FOR FAIRVIEW VITRALOC, AND ARE INTENDED FOR USE BY A TECHNICALLY SKILLED PERSON ONLY. ANY USE OF THE SAME IS AT THEIR OWN DISCRETION AND RISK. © FVA GROUP PTY. LTD.

SOFFIT EXTERNAL CNR - NO DRAINAGE

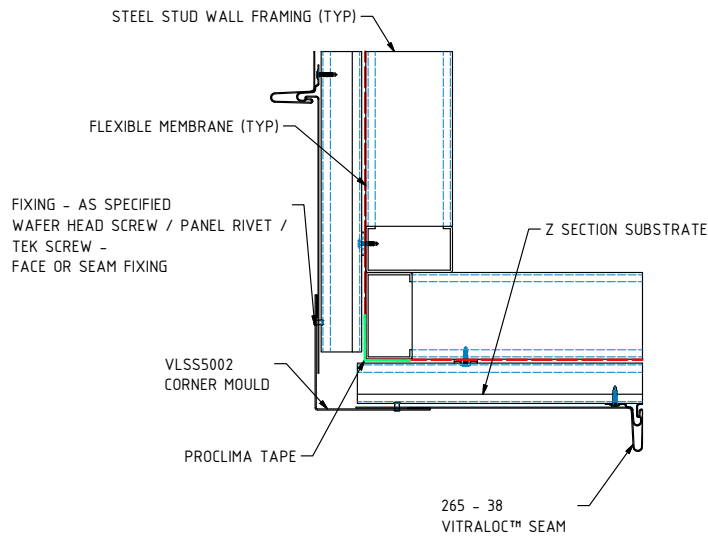

SOFFIT GA

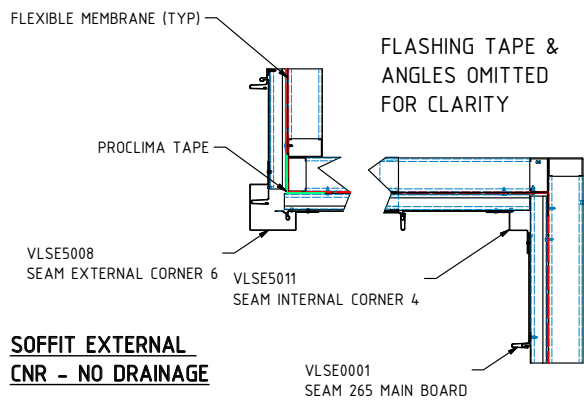

**SOFFIT EXTERNAL
CNR - NO DRAINAGE**

DISCLAIMER: THESE DETAILS ARE LIMITED TO THE GENERALISED DESIGN SPECIFICATION FOR FAIRVIEW VITRALOC, AND ARE INTENDED FOR USE BY A TECHNICALLY SKILLED PERSON ONLY. ANY USE OF THE SAME IS AT THEIR OWN DISCRETION AND RISK. © FVA GROUP PTY. LTD.

PARAPET AND GUTTER DETAIL A

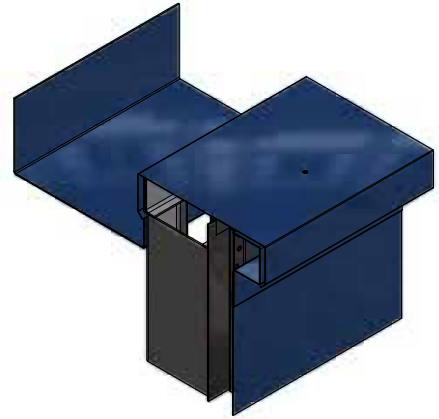
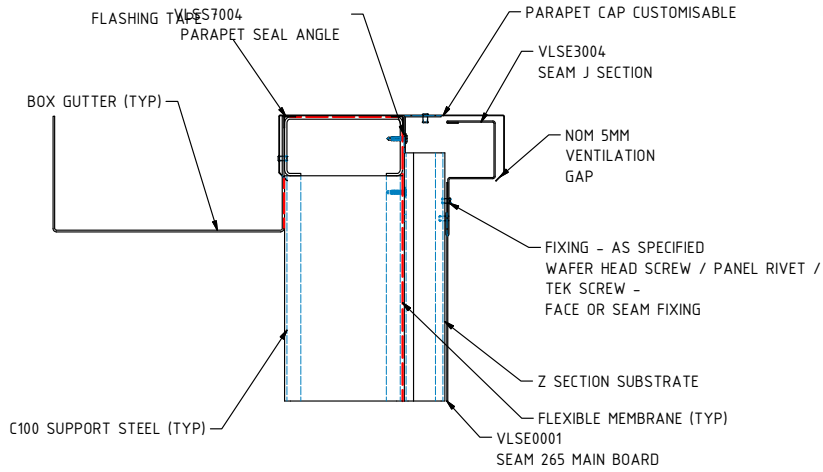

PARAPET AND GUTTER DETAIL B

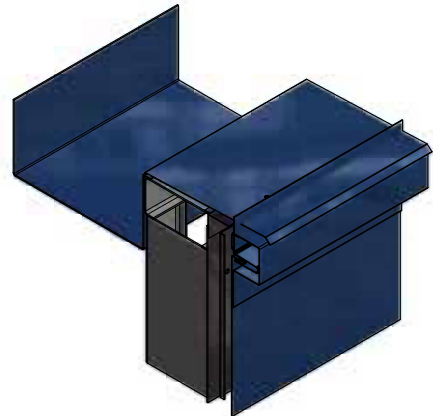
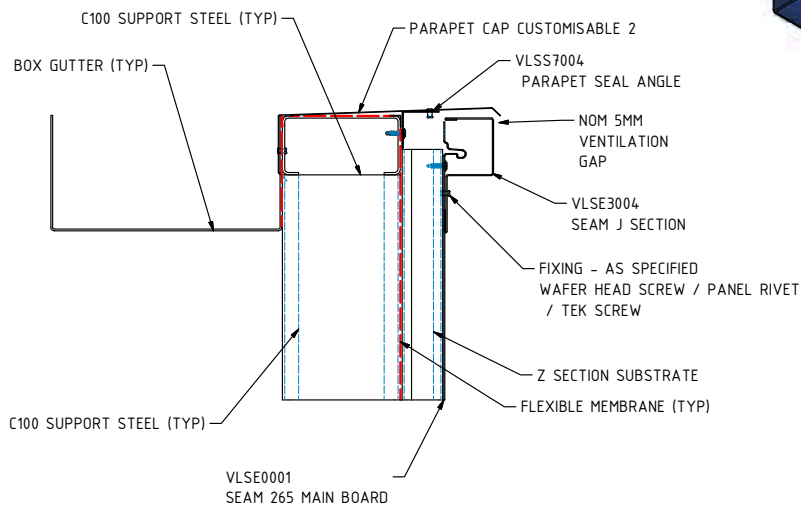

DISCLAIMER: THESE DETAILS ARE LIMITED TO THE GENERALISED DESIGN SPECIFICATION FOR FAIRVIEW VITRALOC, AND ARE INTENDED FOR USE BY A TECHNICALLY SKILLED PERSON ONLY. ANY USE OF THE SAME IS AT THEIR OWN DISCRETION AND RISK. © FVA GROUP PTY. LTD.

SLAB JUNCTION A

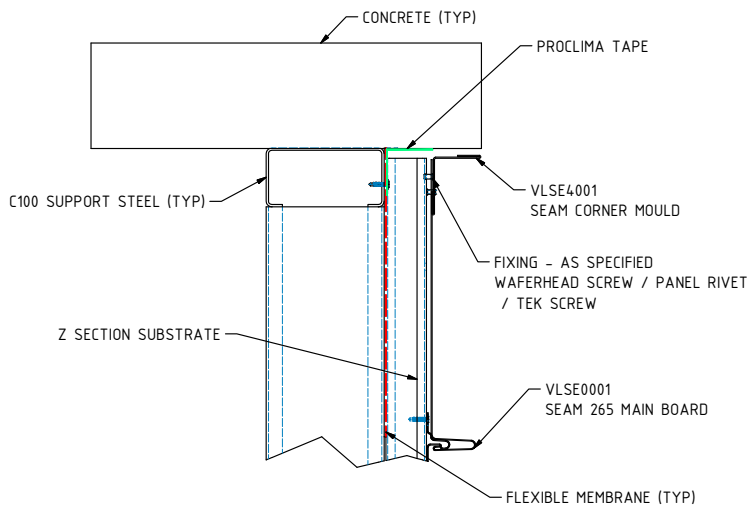

SLAB JUNCTION B

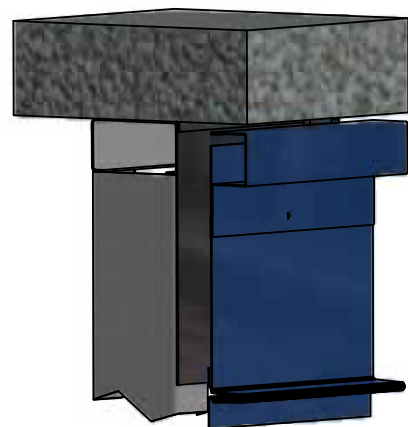
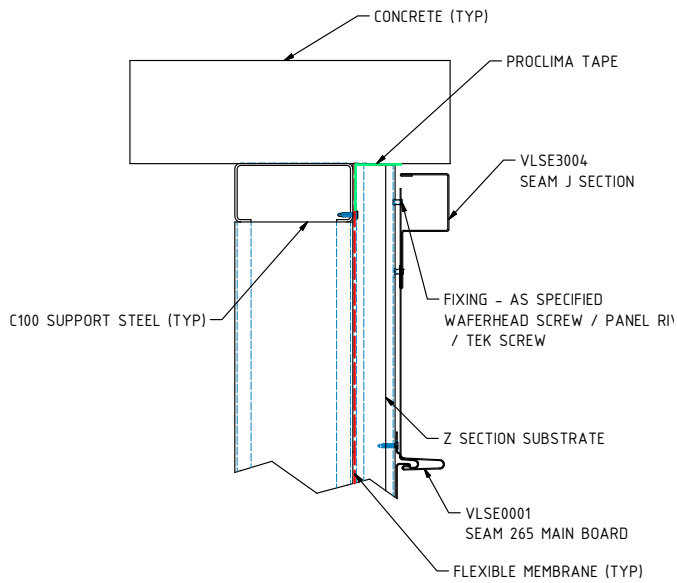

DISCLAIMER: THESE DETAILS ARE LIMITED TO THE GENERALISED DESIGN SPECIFICATION FOR FAIRVIEW VITRALOC, AND ARE INTENDED FOR USE BY A TECHNICALLY SKILLED PERSON ONLY. ANY USE OF THE SAME IS AT THEIR OWN DISCRETION AND RISK. © FVA GROUP PTY. LTD.

SLAB JUNCTION C

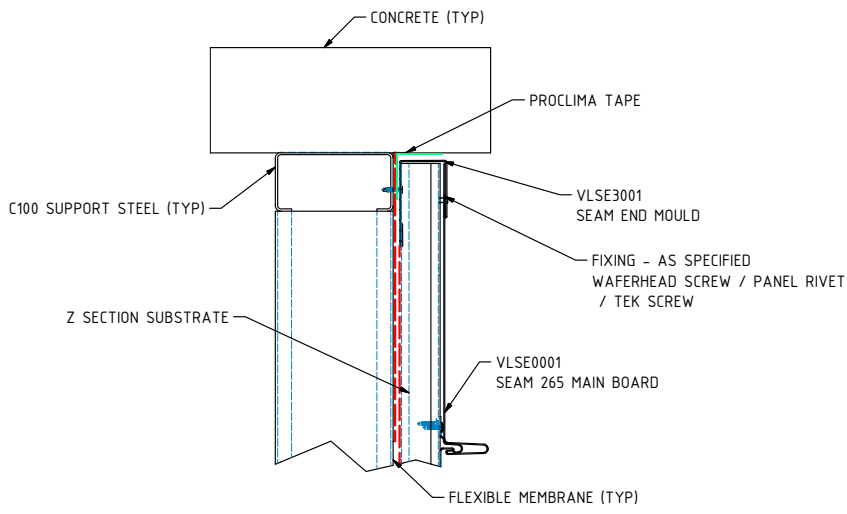

DISCLAIMER: THESE DETAILS ARE LIMITED TO THE GENERALISED DESIGN SPECIFICATION FOR FAIRVIEW VITRALOC, AND ARE INTENDED FOR USE BY A TECHNICALLY SKILLED PERSON ONLY. ANY USE OF THE SAME IS AT THEIR OWN DISCRETION AND RISK. © FVA GROUP PTY. LTD.

9. FABRICATION DETAIL

9.1 FABRICATION CONSIDERATIONS

CUTTING

Vitaloc cladding can be trimmed using conventional tin snips and easily cut using a power saw with a cold cut saw blade or a power nibbler. Avoid the use of abrasive discs as these can cause burred edges and coating damage.

SCREWING

Vitaloc can be screwed with conventional class 3 self-drilling screws for metal.

RIVETING

Riveting is possible with the usual equipment and solid or blind rivets.

DRILLING

Vitaloc can be drilled with centre point twist drill bits normally used for steel. Use High Strength Steel (HSS) bits.

10. WARRANTY

Vitaloc is an incredibly durable material when used in the right application. Please contact your Fairview representative for full terms and conditions.

10.1 IMPORTANT WARRANTY INFORMATION

Maintaining your Vitaloc finish is an important component to upholding your warranty. Cleaning frequencies are based on your project location and provided in the warranty. Therefore, you should document each time your Vitaloc panels are cleaned.

Recommended cleaning agents:

- Mineral spirits
- Organic cleaners
- PH-Neutral Solvents

11. MISCELLANEOUS

11.1 MANUFACTURING QUALITY

A dedication to the total fulfillment of our customer's expectations is reflected by a complete quality control system, beginning at the point of specification and continuing through to delivery of the guaranteed products. All activities are carried out in the manner which:

- Uses the framework of ISO 9001 quality standard to verify the quality of our systems.
- Ensures that our products and services are of the highest standards.
- Creates continuous improvements to our product through the application of the best quality practices.

11.2 HANDLING AND STORAGE

- Cut resistant or leather gloves should be worn when handling product. Foot protection should be worn when handling and transporting product.
- A minimum of two people should be used when moving large panels to avoid scratching.
- To prevent surface damage when stacking Vitraloc, there should be no swarf between panels, and cover panel with paper or foam sheet should be used wherever possible.
- Vitraloc should be stored in a cool dry area where temperature is relatively stable.
- Pallets of Vitraloc should be stored horizontally with adequate support to prevent sagging.

11.3 SUSTAINABILITY

Vitraloc has been designed with an expected performance life of over a vast number of years. All Fairview products have been developed with the health of environment and community in mind. As part of our commitment to using recyclable or reusable materials wherever possible, all Vitraloc panels are 100% recyclable.

12. VITRALOC™ ARCHITECTURAL STEEL CLADDING – TECHNICAL DATA

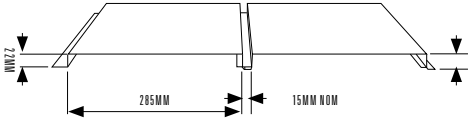
Profile	VitraLoc™ Seam 38	VitraLoc™ Shadow 25
		
Product	VitraLoc™ Seam 38	VitraLoc™ Shadow 25
Rib Height/Depth	38mm	(22mm to) 25mm
Tray width (cover)	265mm (265mm)	285mm (300mm = 285mm + 15mm Express Joint)
Application	Architectural Wall Cladding – Hi-Rise Residential and Hi-Rise Commercial	
Orientation	Vertical and horizontal (or diagonal)	
Cover Width* (Mass/ Unit Length ¹) (Mass/ Unit Area ¹)	38mm Rib: 265mm • 1.80 kg/m • 6.80 kg/m ²	25mm Interlocking Groove: 285mm (300mm cover) • 1.80 kg/m • 6.00 kg/m ²
Optional / Custom Sizes*	38mm Rib: 265mm (standard default) • 180-265mm cover • 266-465mm cover 25mm Rib*: 290mm (default) • 180-290mm cover • 291-490mm cover	25mm Interlocking Groove: 285mm (std. default) • 180-285mm (Add 15mm for Cover) • 286-485mm (Add 15mm for Cover)
Sheet Tolerances	Cover width ± 4mm Sheet length ± 10mm	
Thickness (BMT)	0.55mm (& 0.70mm*)	
Yield Strength	300 MPa (G300)	
Substructure	Fix to steel battens (35mm x 1mm BMT Perforated or Plain S-Section) / steel purlins	
Typical Fixing Method	Concealed fix through perforated screw strip slots using screws	Concealed fix through overlap tongue and groove tab using screws
Fasteners (Class 3 minimum)	Steel Battens: • 10G-16 x 16mm wafer head SDS self-drilling-screw • 10G-16 x 16mm smooth top SDS self-drilling-screw (Buildex) Battens to Frame: 12G-14 Metal Tek screw	
Length	0.8m - 8.0 m - standard (Special delivery requirements apply for lengths over 6m)	
Combustibility	Non-combustible material - Deemed-to-Satisfy provisions of National Construction Code (NCC): Volume 1: Part C1.9.e.(v); and Volume 2: Part 3.7.1.1.	
Fire Test Performance (AS/NZ 1530.3)	Ignitability index: 0 rating in scale of 0-20 Spread of flame index: 0 rating in scale of 0-10 Heat evolved index: 0 rating in scale 0-10 Smoke developed index: 2 and 3 [#] rating in scale of 0-10 (°C-TEX™)	
Thermal Expansion	3mm average per 5m @ 50°C	
Installer	Architectural Roof and Wall cladding to be installed by an experienced and qualified installer, in accordance with installation manual.	
Wall and Cladding Warranty††	Paint 10-15 years (Environment ISO CAT 1-3) Perforation 10-15 years (Environment ISO CAT 1-3)	

Ancillaries	<p>VitraFix 35mm Perforated S-Section Batten VitraFix 35mm S-Section Batten VitraLoc Starter Strip (for Seam 38) Pro-Clima Breathable Waterproofing Membrane / Sarking – Moisture control Pro-Clima Weathertight Sealing Tape and Corner Tape Pro-Clima Sill Tape VitraFix Top Hats - 24mm and 35mm VitraFix Aluminium Angle 32mm x 32mm x 3mm (6m) VitraLoc Standardised Flashings – Refer to VitraLoc Flashings Details VitraLoc Custom Flashings*</p>	
Material Substrate	<p>C-MAX™ - Colour Coated Steel and Metallic Coated Steel Coil</p> <ul style="list-style-type: none"> • Hot-dipped Aluminium/Zinc alloy coated steel coil • Alloy coating weight 150gms/m2 • Manufactured to AS 1397:2011 <p>C-TEX™ – Premium Patterned Steel, Premium Metallics and Woodgrains</p> <ul style="list-style-type: none"> • Hot-dipped Aluminium/Zinc/Magnesium alloy coated steel coil • Manufactured to AS 1397:2011 	
Material Finishes, Coating Class	<p>Satisfies Requirements of AS/NZS 2728:2013 Suitable for ISO 9223:2012 and Atmospheric Classifications C1-C3</p> <p>C-MAX™ - Colour Coated Steel and Metallic Coated Steel Coil</p> <ul style="list-style-type: none"> • SADP – Super Advanced Durable Polyester Coating system • PVDF – Chemically resistant 70% Polyvinylidene Fluoride Coating • FEA - Flexible Exterior Acrylic <p>C-TEX™ – Premium Patterned Steel, Premium Metallics and Woodgrains</p> <ul style="list-style-type: none"> • PVDF - Chemically resistant 70% Polyvinylidene Fluoride Coating 	
Material, Finishes, Colour Range*	C-MAX™ Solid Colours	<p>Lupin White Ferris Grey Pillar Mist Grey Desert Sand Vanilla Olive Grove Dusty Beige Gale Grey Mariana Black Inkstone Bowenfells White Pure White Pottery Beige Esbank Oakly Park Hassans Green McKellars Grey Tarana Grey Littleton Brown Rydal Brown Hartley Red Clarence Blue Hermitage Green</p>
	Solid Colours – Matte	<p>Eclipse Matte Pillar Matte</p>
	Bright Solid Colours	<p>Solace Flare Saffron Rouge Sky^{FEA} Wollemi Green^{FEA}</p>
	Metallic	<p>Rustic Oxide Brushed Ice Brushed Zinc Brushed copper[†] Natural Silver Onyx Brushed[†]</p>
	Woodgrains	<p>Ash Light Pine Dark Teak</p>

Notes:

*Custom products available on request and subject to minimum order quantities and lead times.

‡ Refer to VitraLoc Product Warranty Statement

† Made to Order (Limited Stock) - available on request and subject to minimum order quantities and lead times.

0.7mm BMT cladding material recommended for wide pan products in roof and wall cladding application without plywood backing.

- Do not end lap VitraLoc™ cladding.
- Sheet profiles made of 0.55mm BMT and special order 0.70mm BMT material™ vary in dimensions and should not be used in overlapping configurations.
- Where plywood is used, a breathable waterproofing membrane is recommended between plywood substrate and panel to allow for moisture resulting from minor rainwater ingress and condensation to dissipate.
- Manageable panel lengths for wall cladding are typically 4m.
- Additional precautions are required for horizontal cladding applications. While these are possible, greater attention to detail and workmanship is required for corner flashings around windows and doors. Regular cleaning as part of a maintenance regime is also required to ensure that the horizontal seams are washed, cleaned and maintained to avoid dirt build-up and prevent against corrosion. Fairview recommend that if installing horizontally, use of narrower pan widths and shorter lengths are advisable as they are easier to handle and install as they are less prone to distortion and buckling during installation.
- Oil-Canning
- Oil Canning refers to physical distortions in the flatness of the sheet which results in the visible waviness in the flat areas of metal roofing and walling. Oil canning produces an aesthetic effect inherent in standing seam sheet profiles with wide flat elements.
- Light gauge cold formed metal cladding with wide flat pan areas may exhibit oil canning which can affect the aesthetics of the building design. Oil canning does not have any adverse effects on the structural integrity or the weatherproofing of the sheet.
- Oil canning may also be more pronounced as panel width increases and if supporting members (i.e. battens) are further apart and/or the material base thickness (BMT) decreases as well as the flatness and plane alignment of the supporting structure. Building designers and homeowners should be aware of this and take this into consideration.
- Oil canning will vary depending on the time of day (or year) and angle of viewing and will likely be more noticeable in darker colours (and gloss finishes), and may also be more prevalent in wider pans and longer sheet runs. Oil canning distortion may be mitigated by selection of a narrower width panel.
- Avoid over-driving fasteners as this can contribute to oil canning. Over-driven fasteners can distort and create stresses in the panel.



FAIRVIEW

DEFINING ARCHITECTURE SINCE 1968

AUSTRALIA / NEW ZEALAND / UNITED KINGDOM
SALES ENQUIRIES 1800 007 175 HELPDESK.AU@FV.COM.AU

DECEMBER 2021